



THE COMMODORE 128 IN PICTURES

Commodore 128 Graphics

July/August 1985
\$2.50 U.S.

Commodore

microcomputers

\$3.50 Canada ISSN 0744-8724

FREE GRAPHICS CONVERSION PROGRAM: CHAMELEON

FOR THE 64
TRANSFORMS HIGH-RES GRAPHICS
INTO ANY FORMAT

**GRAPHICS SOFTWARE
FOR PEOPLE WHO CAN'T DRAW**

**GOOD SOFTWARE
FOR PRE-SCHOOLERS**

**FREE PROGRAMS
TO TYPE AND SAVE**

**BUILD A
COMPUTER-CONTROLLED
BURGLAR ALARM**



**MUSICAL
KEYBOARD
BUYER'S GUIDE**



**Now Featuring Computer Wizard
Louis F. Sander's
Tips for Beginners**

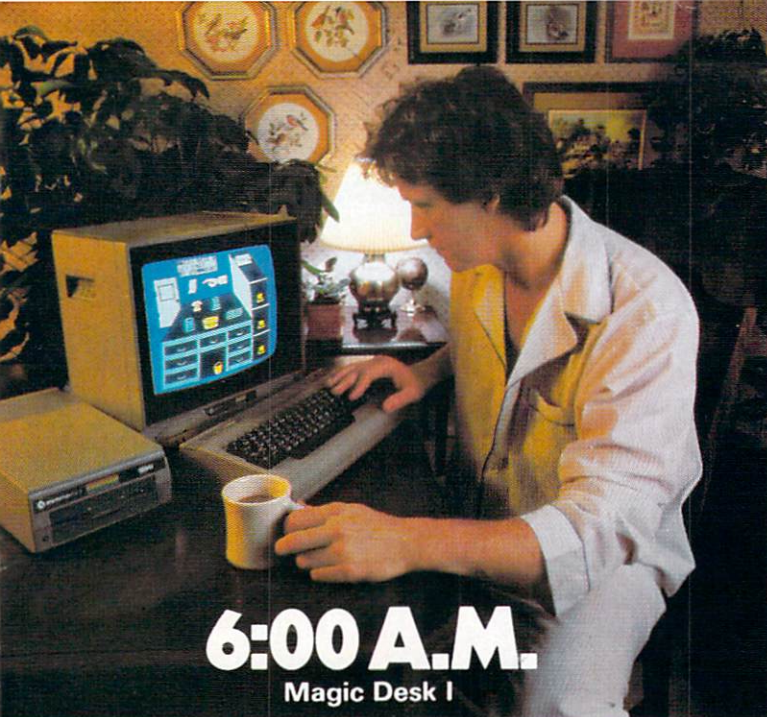

6:00 A.M.
Magic Desk I

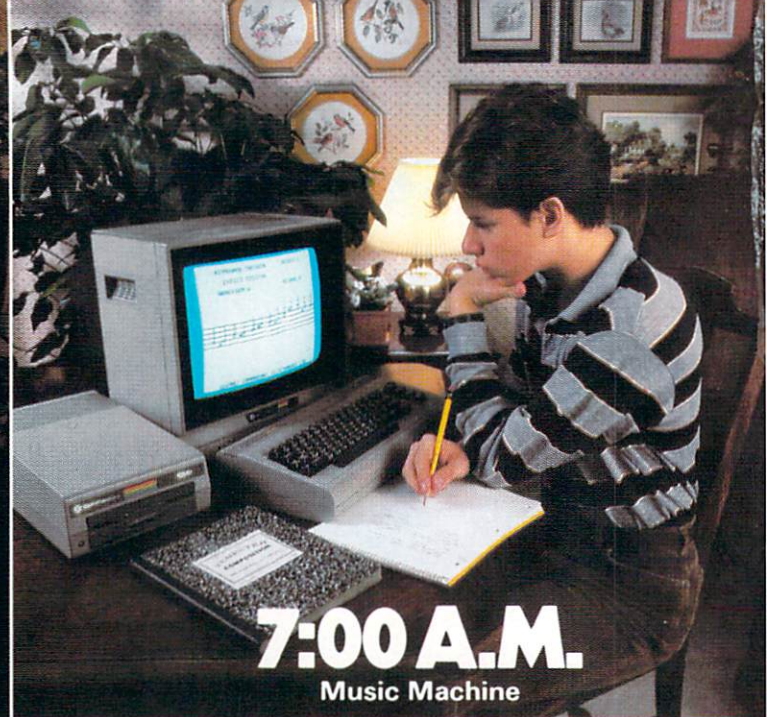

7:00 A.M.
Music Machine

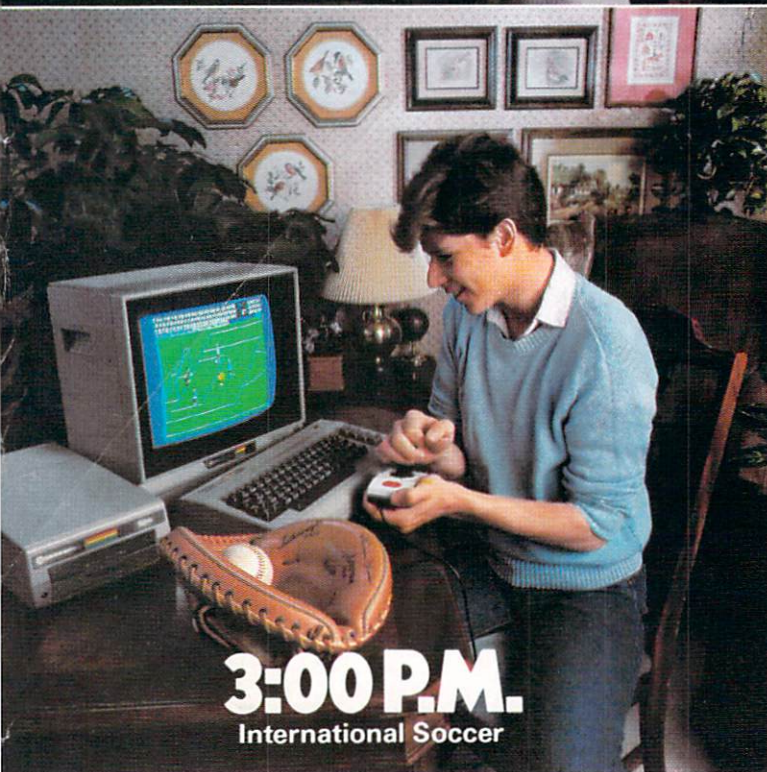

3:00 P.M.
International Soccer

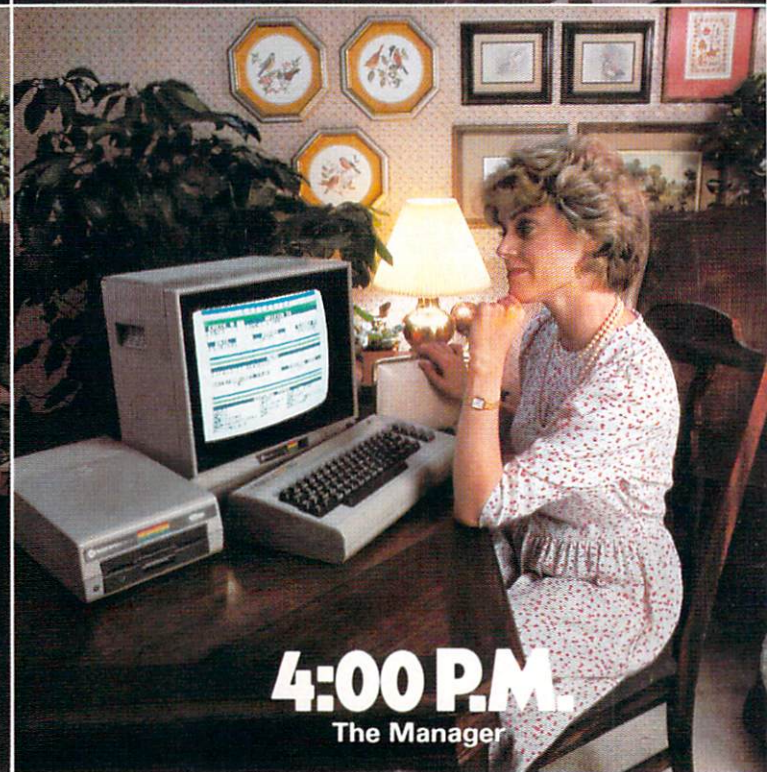

4:00 P.M.
The Manager

**WE PROMISE YOU WON'T
USE THE COMMODORE 64
MORE THAN 24 HOURS
A DAY.**

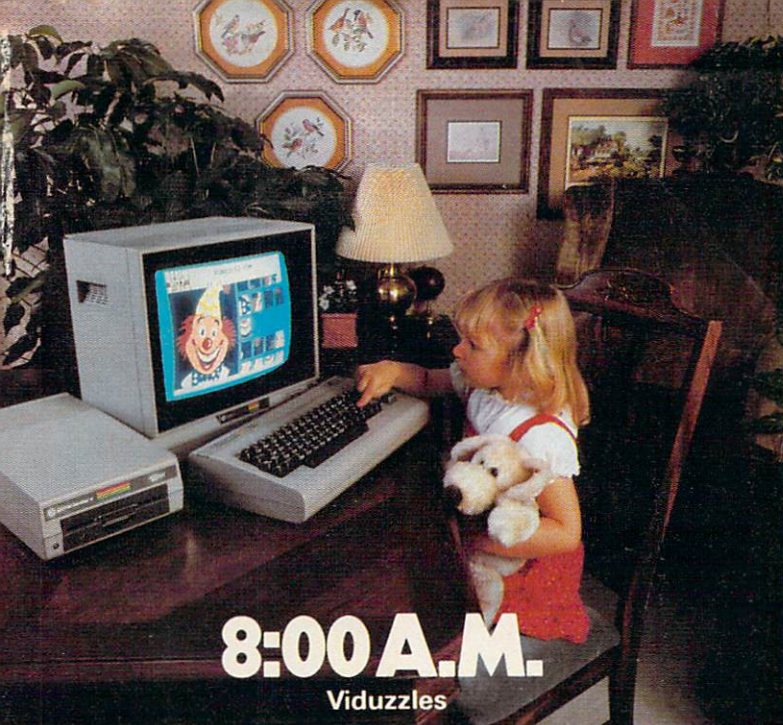

8:00 A.M.

Viduzzles



11:00 A.M.

Micro Cookbook

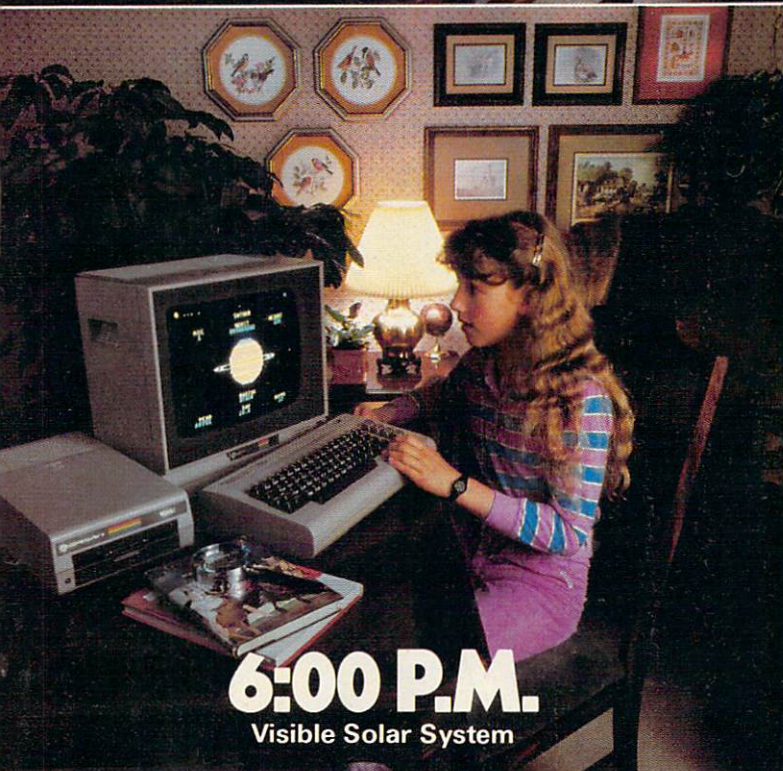

6:00 P.M.

Visible Solar System

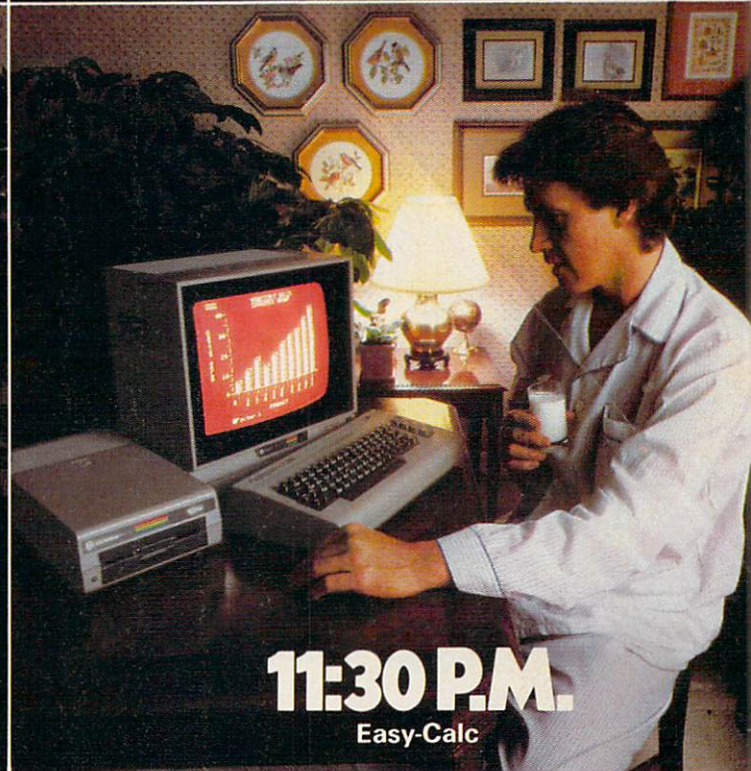

11:30 P.M.

Easy-Calc

It's 6 a.m. Do you know where your husband is?

It's 8 a.m. Do you know where your daughter is?

It's 11 a.m. Do you know where you are?

We do.

We make the Commodore 64™, the computer that's in more homes, businesses and schools than any other computer.

With its 64K memory, its high fidelity sound and its high resolution sprite graphics, it's one powerful computer. With its price—about one third that of

the 64K IBM PCjr™ or the Apple IIe™—it's one affordable computer. (In fact, you can add a disk drive, a printer or a modem and get a powerful computing system for just about the price of those other computers alone.)

And with all the Commodore software programs we make for it, it's one useful computer.

What can you use it for? Just about anything you want to. For fun or profit, for homework or housework, for

higher game scores or higher S.A.T. scores, for words or music. For all hours of the day. And night.

So if you're looking for a computer, it pays to look into the Commodore 64.

You'll definitely have enough money for it. Just make sure you have enough time for it.

COMMODORE 64

IT'S NOT HOW LITTLE IT COSTS,
IT'S HOW MUCH YOU GET.

It's Absolutely Shocking!!!

After all these years, **CMS Software Systems** is still the only company providing professional quality accounting software for the complete line of **Commodore business computers**.

Whether you own an 8032, 8096, SuperPET, B-128, C-64, or the new C-128, we have a professionally written, fully integrated Accounting System designed especially for you.

Introduced in 1979, the **CMS Accounting System** was the first Accounting System available for Commodore computers. Not satisfied with just being first, we have continued to update, expand, and improve until today, the **CMS Accounting System** is widely recognized as one of the finest Accounting Systems available for any computer.

Now Available for the Commodore C-128



- General Ledger
- Accounts Receivable
- Billing
- Accounts Payable
- Job Costing
- Payroll

\$179.95

Complete Price

For more information see your Commodore dealer or call Cathy York at 214/289-0677.

CMS Software Systems, Inc. • 2204 Camp David • Mesquite, TX 75149

Commodore

microcomputers

USER HOTLINE 4

LETTERS 8

NEWS 10

SOFTWARE REVIEWS

Write Now/File Now/Mail Now reviewed by Tracie Forman-Hines 16
Kwik-Write reviewed by Dan Rustin 18
Right Again! reviewed by Rev. Dr. Max Nuscher 20
PFS:Report reviewed by Al Willen 22
Home Pak reviewed by Howard Millman 26
The Music Shop reviewed by Rick Teverbaugh 27
Master Composer reviewed by David Brooks 28
Insta-Ledger reviewed by Cheryl Peterson 30
Fast Load reviewed by Ervin Bobo 32
Fleet System 2 reviewed by Mark Cotone 34
Write File reviewed by Ted Salamone 36

COMPUTER WIZARD

Keyboarding and the Screen Editor by Louis F. Sander 40

PROGRAMMERS' TIPS

Display T & S by Jerry A. Sturdivant 44
Memory Finder by Jerry A. Sturdivant 47
Self-Modifying Machine Language by John J. Karcher 48
XDOS by C.D. Lane 50

TECHNICAL TIPS

Build a Burglar Alarm by Dan Fabrizio 53
Random Thoughts by Mark Zimmermann 62

SPECIAL SECTION:

SOFTWARE FOR CHILDREN

Donald Duck's Playground reviewed by Joyce Worley 82
Movie Musical Madness reviewed by Tom Benford 83
Addition Magician/Moptown Parade reviewed by George Beekman 84
Big Bird's Funhouse reviewed by Tom Benford 85
Swiss Family Robinson and Below the Root reviewed by Joyce Worley 86
Tuk Goes to Town reviewed by George Beekman 87
Stickybear reviewed by Kelley Essoe 88

BOOK REVIEWS

Inside the 1541: A Look at Three Books by Walt Lounsbury 90

FEATURES

THE COMMODORE 128 IN PICTURES 66

An intimate look at Commodore's new triple-threat computer.

VACATION COMPUTING 70

For those who want to get away from it all—all except their computer, that is—some suggestions for taking your silicon friend along. by Tom Benford

THE ELECTRONIC REMBRANDT 72

Graphics software has made it easier than ever to create electronic art on your computer. Among all the packages that are out there, which is best for you? by Joyce Worley

PROGRAMS FOR PEOPLE WHO CAN'T DRAW 74

If you're all thumbs, you can combine pre-drawn forms to make pretty pictures on your 64. by Joyce Worley

A BUYER'S GUIDE TO MUSIC KEYBOARDS FOR THE 64 76

If you're a professional musician you need a different kind of keyboard than a home plinker does. Here's an overview of choices. by Tom Benford

CHAMELEON: GRAPHICS CONVERSION MADE EASY 100

Convert any high-res graphics screen to any other format—Koala to Micro Illustrator to Flexidraw to whatever—with this high-powered program. It's yours for the typing. by David Darus and Louis Wallace

COMMODORE 64 USERS ONLY

ManagerMania by Cathy Martino 94
Assembler Development System by Walter Piotrowski 98

COMMODORE 128 USERS ONLY

Commodore 128 Graphics: Sprites by Larry Greenley 114

USER GROUPS 116

HOW TO ENTER PROGRAMS IN COMMODORE MICROCOMPUTERS 121

ADVERTISERS' INDEX 128

Customer Support Hotline

Compiled by
Rick Gallagher
Commodore
Customer Support



If you've got a question about your Commodore equipment, contact Commodore's toll-free hotline: 1-800-247-9000.

Q: How many typewritten pages can *Easy Script* hold before you have to save the information to disk?

A: *Easy Script* can hold approximately 12 to 13 pages before you have to save the information to disk. This can change depending on how you use RETURN's, and the amount of spacing between lines. There is a link file option available which allows the printing of longer documents.

Q: How can I send special characters to the printer from *Easy Script*?

A: There are two steps to defining special control characters in *Easy Script*. First, you must define the characters within the text of the document, then you issue the command from within the command mode of *Easy Script*. They are accomplished like this:

At the beginning of the text (or at least sometime prior to when you want to send the commands), assign the ASCII codes for the commands that you want to send to the printer to a number between one and nine. This is how *Easy Script* will identify the command. You do this just as you would set other program parameters in format mode. For example, to define an escape sequence to set the printer to print in italics (for a Gemini Star printer), enter the following at the top of the text:

F3 (function three key to get into format mode)

1 = 27:2 = 52:3 = 53<RETURN>

where 27 is the ASCII code for escape, 52 is the ASCII code for italics, and 53 is the ASCII code for standard

print mode. Don't forget to include the code return from the special print mode you are defining.

Now that the codes are defined, you can use them in the text just like any other print mode. When you come to a place in the text where you want to turn on italics, press F1 (function key one for command mode), then press the number one. This will include CHR\$(27) in the text for escape, and print a "1" on the screen in reverse print. Now that escape is set, you can send the code for the function you want to enable. Press F1 again to get into command mode again, and press "2" to include CHR\$(52) in the text. Number two will appear on the screen in reverse video. Now, whatever you type from now on will print out to the printer in italics (when you print it). After you have typed in the word or sentence that you want italicized, press F1 once more to get into command mode, and press "3" to include CHR\$(53) in the text. When it is sent to the printer, it will return to standard print mode.

Any ASCII code can be sent to the printer in this way. Consult your printer manual to find out what codes are required for the special functions that your printer is capable of.

Q: I have the Commodore cartridge *Magic Voice*. How many words was it designed to hold?

A: *Magic Voice* was designed to hold 235 words in its vocabulary.

Q: Can I use a double-density disk with my 1541 disk drive?

A: Yes. You can use a double-density disk with a 1541, but it will only fill to single-density capacity.

Continued on page 6

Publisher
Robert M. Kenney
Assistant to the Publisher
Virginia O. Dike

Editor
Diane LeBold
Technical Editor
Jim Gracely
Assistant Editor
Carol Minton
Contributing Editor
Louis F. Sander

Art Director
Robert C. Andersen
Cover Photo
Eric Meola/Image Bank

Advertising Coordinator

Sharon Steinhofer
Advertising Assistant
Cheryl Griffith

Circulation Manager
John O'Brien

Circulation Assistant
Kathy Reigel

Advertising Representatives

SOUTHEAST/WEST

Warren Langer, Spencer O. Smith

Warren Langer Associates

1337 NW 84th Drive

Coral Springs, FL 33065

800/635-6635

In Florida call:

305/753-4124

MIDATLANTIC
AND NEW ENGLAND

Bob D'Ambrosio

Target Media

114 E. Main Street

Bogota, NJ 07603

201/488-7900

MIDWEST

Pamela S. Fedor

Randy Fedor

700 River Road

Fair Haven, NJ 07701

201/741-5784

Commodore Microcomputers, Volume 6, Number 4, Issue 36, July/August 1985, ISBN 0-88731-044-3.

Commodore Microcomputers (ISSN 0744-8724) is published bi-monthly by Contemporary Marketing, Inc., 1200 Wilson Drive, West Chester, PA 19380 U.S.A. U.S. subscriber rate is \$15.00 per year. Canadian subscriber rate is \$20.00 per year. Overseas subscriber rate is \$25.00 per year. Questions concerning subscriptions should be directed to Contemporary Marketing Subscription Department, Box 651, Holmes, PA 19043, phone (800) 345-8112. In Pennsylvania (800) 662-2444. Copyright © 1985 by Contemporary Marketing, Inc. All rights reserved.

Contemporary Marketing also publishes *Commodore Power/Play*.

Application to mail at Second Class postage rates is pending at West Chester, Pennsylvania 19380 and additional mailing offices. POSTMASTER send address changes to: Contemporary Marketing, Box 651, Holmes, PA 19043.

VIC 20™, Commodore 64™ and Super PET™ are trademarks of Commodore Electronics Ltd. PET® is a registered trademark of Commodore Business Machines, Inc. CBM® is a registered trademark of Commodore Electronics Ltd.

ABC Membership applied for.

"Thanks for the memory."



INTRODUCING THE COMMODORE 128.™

It's here. And it's going to make a lot of Commodore 64™ owners very happy. A personal computer with a 128K memory and 80-column capability that's still compatible with all the peripherals and over 3,000 programs designed for the Commodore 64.

In fact, the new 128 is almost like getting three computers in one. That's because it can run as a 64, a 128 and in a CP/M™ mode. Or it can even be expanded to a full 512K memory. And that's about as "personalized" as a personal computer can get. It's intelligence that can match your

own versatility. And then, even take it to a higher level.

There's more than a bigger memory.

There are a lot of extra features we didn't forget. Like a handy numeric keypad for data-entry efficiency and accuracy.

An expanded keyboard that puts more commands at your fingertips for easier programming. So you can be a whiz at using more varied graphics and text. Or a musical genius playing full three-part melody in any tempo you set. And there's even a "help" key

that comes to your rescue, listing programming errors on-screen with the error in reverse field.

There's also a new faster disc drive. With a separate "Burst" mode that can transfer up to 3,000 characters per second. Just in case you're a speed demon.

"Thanks for the memory!" You're welcome. And for the expandability. And compatibility. And versatility. And for making it all very affordable. After all, one of the other things that should go into a more intelligent computer is a price that makes sense.

COMMODORE 128 PERSONAL COMPUTER
A Higher Intelligence

Tired of Paying High Prices . . .

CHECK THESE PRODUCTS FOR THE C-64!

New Software

Prime Factor BASIC 3.0 \$49.95
(500 Digit Precision Math Package)
Write for Free Flyer

Sky Travel 24.95

Software from Datamost

Ankh 16.95
Aztec 16.95
Mr. Robot and his Robot Factory . . . 16.95
MyChess II 24.95
Paint Magic 29.95
Kwik Load! 16.95
Kwik Write! 16.95
Inside Commodore DOS 22.95
1541 User's Guide 22.95

Books from Datamost

Inside Commodore DOS 18.95
1541 User's Guide 18.95

Software/Book Combo's

Inside Commodore DOS 39.95
1541 User's Guide 39.95
Commodore 64 Construction Kit . . . 25.95
Games Commodore's Play 19.95

Send check or Money order to:

INEXSOFT

"Inexpensive Software & Books . . .
Our name and our fame"

21115 Devonshire, Suite #401B
Chatsworth, CA 91311
(818) 882-1686

We pay the postage. CA residents add
6.5% sales tax. Most Datamost products
available. Software pre-tested on request.

USER HOTLINE

Continued from page 4

Q: When using the Commodore *Business Accounting System* with two disk drives should the program disk be in drive number eight or nine?

A: The program disk should be used in drive number eight and the data disk in drive number nine.

Q: How do you change the device number in the second drive while using Commodore's *Business Accounting System*?

A: To change the device number using the hardware method, you must cut the number one jumper. This changes it to device number nine. If you have any questions on how to cut a jumper, you can contact Commodore by calling, toll-free, 1-800-247-9000. After cutting the jumper, you must load the main menu program and select Configuration File Maintenance. Within this, choose sub-menu one, Change Configuration. Change the code from 80 for one drive to 90 for two disk drives. Be sure to remove the write-protect tab from the disk, because you will be writing the new configuration code on the disk.

A second way to change the device number is to use the software method. Initially, the primary drive should be turned on and the secondary drive left off. Again, change the coding from 80 to 90 without the write-protect tab on the disk. Next, choose sub-menu two, Change Unit Number. The program will prompt the end user to turn the drives off and on in the proper order.

Q: How do you back up a data disk using the *Business Accounting System*?

A: When backing up a data disk, it is necessary to use the 1541 disk backup program on the *Business Accounting System* menu. When in the main menu, select 00, then select option nine. If it doesn't load, type in LOAD " " , 8 and this will load it. Then the program will prompt the end user what to do next.

Q: How can I convert VIC 20 programs to run on my 64?

A: There are a number of adjustments to be made. You must first convert all memory locations for the VIC to locations that do the same thing on the 64. Next, you will need to adjust for a 40-

column screen, rather than a 22-column screen. To get more details on exactly what changes need to be made, consult *Commodore Power/Play*, Spring 1984, page 29, or *Commodore Microcomputers*, Issue 28 (January 1984), page 85.

Q: How can I clear up the picture on my TV when I use my computer?

A: If you are experiencing an unclear picture on your television set, you should first try to tune your set, and try the other possible channel (3 or 4). If this doesn't correct the problem, here are some other suggestions.

- 1) Turn down the brightness and boost the contrast.
- 2) Reorient the antenna.
- 3) Relocate the computer in respect to the receiver.
- 4) Plug the computer into a different outlet so the receiver and computer are on different branch circuits. If you still have a problem, you should contact a dealer or TV repair person.

Q: How can I retrieve a file that I scratched off my disk?

A: When a file is scratched, it is not necessarily removed from the disk, only from the directory listing. Although the file appears to have disappeared, it may be possible to retrieve it by using a program on the new 1541 test demo disk called "Unscratched." If you don't have this program on your test demo disk, send a formatted disk to Commodore Customer Support and they will send you a copy at no charge.

Q: How can I list my directory without wiping out whatever is in memory?

A: When you type LOAD "\$", 8, it loads a listing of your directory into memory, and wipes out whatever is there. To list a directory without doing this, use the DOS Wedge on the 1541 test demo disk. This loads into high memory and you can list a directory by typing @\$0. This will list your directory to screen memory and not BASIC program memory. The Plus/4, Commodore 16 and the new Commodore 128 have this ability built in, and the directory can be accessed by hitting the F3 function key.

Circle Reader Service No. 21

COMPUTER T'SHIRTS

FOR HOME, SCHOOL, AND OFFICE!

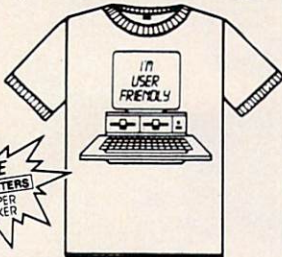

Made in U.S.A.

The **ULTIMATE** Software!

Command instant attention!

A MUST for all computer lovers!

BRIGHT GREEN (L.C.D.) LETTERS

CUSTOM SILKSCREENED ON 50/50 BLEND

— HIGH TECH DESIGN! —

Five popular styles to choose from.

Order Today! Only \$8.95 ppd

Simply select Shirt#, and Color! below

LET'S SEEK, PEEK & POKE (#1) White #1 Pink #2 Blue #3
TAKE A BYTE OUT OF ME (#2) Green #4 Grey #5 Red #6
I'M USER FRIENDLY (#3) Black #7
HAPPINESS IS A PROGRAM THAT WORKS (#4)
I ♥ COMPUTERS (#5) SIZES S—M—L—XL

Please send me
Shirt# _____ Color _____ Size _____ / Shirt# _____ Color _____ Size _____
Use additional sheet if necessary

COMPUTER NOVELTY CORP.
P.O. BOX 2964
FREEPORT, TEXAS 77541
Enclose \$8.95 ppd each TX Res. 6% tax

NAME _____
ADDRESS _____
CITY _____ STATE _____ ZIP _____
©cnc

Circle Reader Service No. 7

YOUR COMMODORE 64™ CAN NOW USE STANDARD APPLE™ II+ HARDWARE AND SOFTWARE



WITH THIS

At Mimic we believe that you and your computer should dictate the choices of hardware and software you can use.

The Spartan™ was developed to allow you to choose the hardware and software that best suits your needs.

Our goal in designing the Spartan™ was simple. To take what you already have and give you more.

Mimic Systems is proud to give you the Spartan™
The Apple™ II+ emulator for the Commodore 64™

Spartan™ Suggested Retail Prices:

The Spartan™ (includes BUSS, CPU, and DOS cards) \$599.00

BUSS card \$299.00

CPU card (requires BUSS card) \$199.00

DOS card (requires BUSS and CPU card) \$199.00

(All prices in U.S. Funds. Freight not included.)

American Express, Visa and MasterCard accepted.

Commodore 64 and Commodore logo are trademarks of Commodore Electronics Ltd. and/or Commodore Business Machines, Inc. Apple® II+ is a trademark of Apple Computer, Inc. Spartan™ is a trademark of Mimic Systems Inc. and has no association with Commodore Electronics or Apple Computer, Inc. The Spartan is manufactured by Mimic Systems Inc. under license granted by ATG Electronics Inc. of Victoria, B.C., Canada.



MIMIC

FOR INFORMATION WRITE:

MIMIC SYSTEMS INC.
1112 FORT ST., FL. 6B
VICTORIA, B.C.
CANADA V8V 4V2

To Order Call:

1-800-MODULAR
(663-8527)

Speedwriter

To the Editor:

I was very interested in your review of *Speedwriter* in your March/April issue. I've been using *Speedwriter* with my Commodore 64 since the program first became available.

According to the reviewer, the run time library (RTL-64) cannot be copied from the compiler disk to another disk. This is not true. LOAD "RTL-64", 8 will load the program into memory. SAVE "RTL-64", 8 will save the program to any disk. However, the *Speedwriter* documentation cautions that you not run either the compiled program or RTL-64 between the load and save.

I hope that this observation will be helpful to prospective users, and current reviewers, of *Speedwriter*.

Jack Ryan
El Dorado, Arkansas

Script 64

To the Editor:

I recently received the *Script 64* word processor. I read your article in the recent issue of *Commodore Microcomputers*, and you said you need a dongle to run the program. However, according to the update that came with the program, you no longer require the dongle to run the program.

I thought your readers might be interested in this new feature.

Kenneth J. Davies
Washington, New Jersey

Do As I Say, Not As I Do

To the Editor:

Your publication has just provided our family with a great deal of laughter and also a lesson in advertising techniques.

As relatively new acquaintances to the computer world, we have grown to be Commodore lovers through our VIC 20. We are going to expand to the more sophisticated Commodore 64 with the demands of our growing children and business needs.

While reading your February 1985 issue of *Commodore Microcomputers*, my wife came upon a rather interesting dilemma. She was intrigued by your portrayal of the computers in the

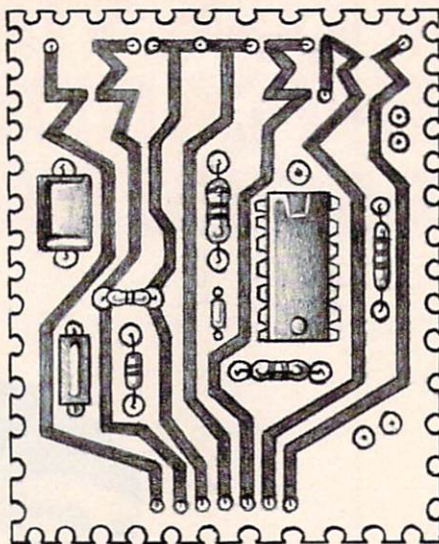

beautiful pictures shown in the Commodore advertisements. At the same time, she was confronted with what seemed to be a paradox in your article on page 87 entitled, "Using the Computer to Help Your Child Learn." In the advertisement section, you picture people in a relaxed pose, intent on their enjoyable problem-free computer programs with food *ad libitum*. However, in your educational article your writer specifically states . . . "Do not let your child place food or drinks near the computer."

My children now understand that what you say and what you sometimes do are not always the same; although, they also realize that to project an image of a fireplug onto the screen of your computer monitor within sight of the bulldog is certainly asking for damage to your hardware.

Thank you for your most informative articles in ways only your readers will know. We will still remain faithfully yours, Commodore. **C**

The Woodwards
Chambersburg, Pennsylvania

Flex File

To the Editor:

I enjoyed reading "Keep Those PET's Working" (March/April). However, I was left with some confusion concerning *Flex File*. In our school district, we have a considerable number of PET's and use *Flex File* in several of the offices. We originally purchased copies of the first version of *Flex File*, then later *Flex File 2.0*. Recently I purchased *Flex File 2.1*,

which will run on a PET and does not require the dongle. This version does permit you to print any record on the screen. I also understood the author to say that the selected records had to go the printer. Not so—when setting up the print format, you can have it print either to the disk, printer, or screen. I have never seen *The Consultant*, but so far I haven't needed to look beyond *Flex File*.

I didn't particularly want this to sound like a commercial, but the weaknesses mentioned have been corrected in the latest version.

Ray Reed
Nampa, Idaho

Disk Companion for Commodore Microcomputers

To the Editor:

When are you going to put your Commodore 64 computer programs that you list in your publications on disk and cassette for sale to us subscribers? It sure would help us people who don't care to strain our eyes and spend hundreds of hours of typing in the listings and then have to debug the program.

Thanks for your time and patience.

Robert Desko
Endicott, New York

Loadstar comes on a two-sided diskette that has unprotected programs for your Commodore 64 in addition to the 64 programs featured in *Commodore Microcomputers* that month. For more information, see the *Loadstar* advertisement in this magazine. **C**

Commodore Microcomputers

welcomes letters from readers. Do you have an unusual application for your Commodore computer? Do you wish to comment on an article? Would you like to make a suggestion on how we can better serve our readers? Please send them to:

Commodore Microcomputers
1200 Wilson Drive
West Chester, PA 19380
Attn: Letters

New Hard Disk Signals Full Speed Ahead For Commodore 64[®]

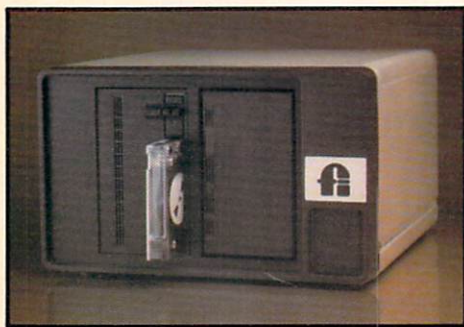

FII's Lt. Kernel with streaming tape option installed.

Speed. It's a major factor in the business microcomputer world. Now, Fiscal Information Inc., has broken the speed barrier with the first really fast hard disk subsystem for Commodore 64. How fast is really fast? It's fast enough to load a full screen of high-resolution color graphics (about

11 kbytes) in less than one second! It is, in fact, up to 43 times faster than Commodore's standard 1541 floppy disk drive.

FII's Lt. Kernel™ disk drive carries an on-board DOS. It's a substantial upgrade to C64's BASIC, since it adds run-time functions and several CP/M®-like command line functions. Lt. Kernel interfaces via the expansion/cartridge port and transparently implements all Commodore 1541 DOS functions.

Capacity of 10 or 20 MB is standard; larger capacities and integral streaming tape backup are available as extra-cost options.

Price of the 10 MB Lt. Kernel is \$1,595. Learn how your Commodore can sail into serious business or scientific applications at full speed. Write Fiscal Information Inc., or telephone 904/253-6222.

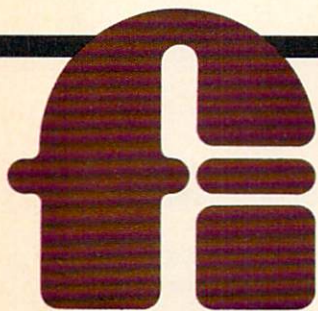
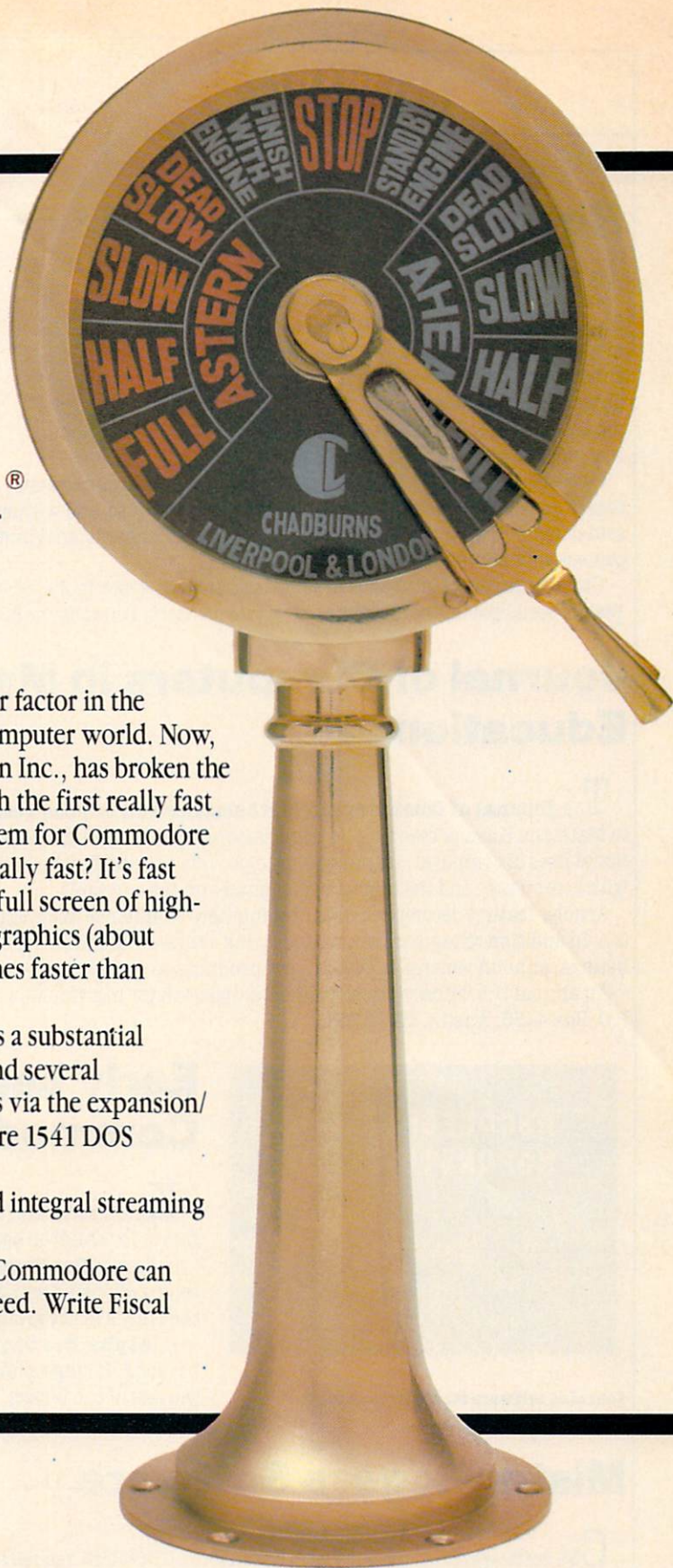

FISCAL INFORMATION INC.

P.O. Box 10270/Daytona Beach, FL 32020

Circle Reader Service No. 9

Commodore 64 is a trademark of Commodore Business Machines.

CP/M is a trademark of Digital Research, Inc.

Lt. Kernel is a trademark of Fiscal Information, Inc.

Reset Switch

Master Software (6 Hillery Court, Randallstown, MD 21133) has introduced Reset Master for the VIC 20 and Commodore 64. Reset Master will reset your computer without shutting off the power, and will restore control of the computer to the operator in case of computer lock-up. Four renew programs are included to restore the BASIC program that was in memory before using Reset Master.

Reset Master plugs into any serial port on your computer system, and therefore is installed without opening the computer case and without any soldering. Rather than just shorting the computer's reset signal line to the ground, Reset Master contains electronic circuitry to protect your computer.

Other important features of Reset Master include a two-foot cord, which acts as an extension cord on your serial bus, and two female serial ports, enabling the use of two printers. It retails for \$24.95.



Reset your computer without shutting off the power.

Journal of Computers in Math and Science Education

The **Journal of Computers in Mathematics and Science Teaching**, published by the non-profit Association for Computers in Math and Science Teaching, is a professional quarterly publication for mathematics and science teachers interested in instructional uses of computer. Its purpose is to provide a forum for the exchange of information about teaching mathematics and science with computers, and the impact of computers on the curricula.

Articles feature descriptive uses of computers to enhance instruction, tutorials, and research studies on teaching with computers. In addition to regular columns covering educational concerns, departments include reviews of software and books, program listings, announcements of events, new products, and the latest news in computing.

An annual U.S. subscription/membership is \$18 for individuals and \$36 for libraries. For further information, contact JCMST, P.O. Box 4455, Austin, TX 78765.

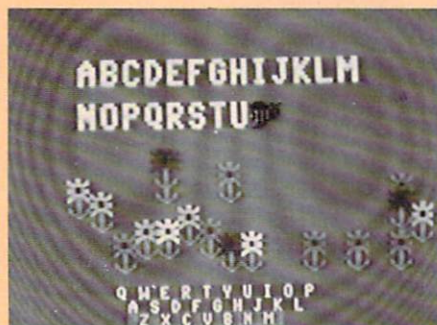

Learning software for children three to seven.

Early Learning Software for the Commodore 64

Kidbit Software (7001 Sunkist Drive, Oakland, CA 94605) has released two games for children ages three to seven.

In **Same/Not Same**, you attempt to blast off in a space ship that you built yourself by choosing which of the shapes, colors, directions, or letters is different from the others in the group. A child starts as a cadet and works up to fleet commander.

In **Alpha-Bee Sequence**, a bee is on its way home to its hive buzzing the alphabet song. It sings a few letters, but then forgets the rest. The child helps it remember the rest of the letters.

Both are sold together on one disk and retail for \$26.95.

Mister Rogers Software

CBS Software (One Fawcett Place, Greenwich, CT 06836) has released the first computer program for the Commodore 64 developed by Emmy Award-winning children's television host Fred Rogers.

Intended for children ages four and up, **Many Ways to Say I Love You** allows children to create their own electronic greeting cards to share with family and friends. Picture-driven activity menus make the program easy to use. The program features a selection of colorful greeting card backgrounds and borders, dozens of "stickers" (animated graphics), and electronic crayons. Delivery of the greeting cards is enhanced with animation and music from a selection of favorite childhood tunes including Mister Rogers' own "Many Ways to Say I Love You."

General Electric Introduces Computer Peripherals for Commodore Computers

General Electric Consumer Electronics (Electronics Park, Syracuse, NY 13221) has introduced a letter quality printer with interface modules, a modem, switchable monitor/television sets, and a program recorder, all of them Commodore compatible.

Modem

The Model 3-8200 modem has an acoustic coupler for use with hard-wired phones, and a direct mode for operation with modular jacks. It can operate with nine-volt batteries for use away from home, and when AC power is unavailable. Automatic features include a power on/off switch with LED to signal when the modem is ready to receive or send transmissions, as well as automatically switchable answer/originate modes. Once tied into a data base, the modem will automatically switch for both full and half-duplex operation. It transmits data at up to 300 baud, and is capable of operation with most major computer and telephone systems. With a full two-year warranty, the manufacturer's suggested retail price is \$119.00.

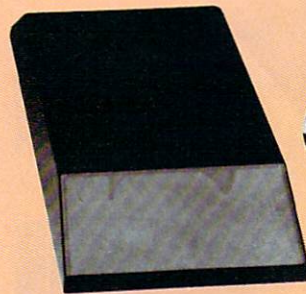

Printer

The Model 3-8100 printer uses a variety of paper—plain or thermal—rolled, fanfold, or cut sheet. It also features automatic line feed, automatic form feed, and an out-of-paper sensor. It has high-resolution 16-dot matrix print quality using thermal transfer technology and a choice of printing speeds (25 or 50 characters per second). It uses the General Electric printer interfaces. Manufacturer's suggested retail price is \$299.95 and the interfaces are \$89.95. They are backed by a two-year warranty.



General Electric introduces computer peripherals for Commodore computers.

Monitors

The Model 13BC5509 color monitor and the Model 12XR5204 black and white monitor also serve as television sets. Their high resolution offers high quality graphics when operating as a monitor, and outstanding picture quality when used as a portable television. They handle 80 character-per-line displays, and also have a display width reduction capability to prevent text from being lost off the edge of the screen. They accept composite video input as well as standard antenna connectors for television, VCR's, video games, or video disc players. The color monitor/television has a manufacturer's suggested retail price of \$489.95, and the black and white unit is \$129.95.

Program Recorder

The Model 3-8156 Program Recorder is a compact tape drive (1 1/2" high by 4 3/4" wide by 7" deep) available at the manufacturer's suggested retail price of \$69.95. Features include a digital program indicator, variable tone and data level controls, and a complete jack pack for the computer interface. Interface cables are included.

Mitey-Mo Modem Update

Mitey-Mo, the 300-baud modem for the Commodore 64 marketed by Computer Devices International (1345-A2 Doolittle Drive, San Leandro, CA 94577), now includes the **Smart 64 plus 4** terminal software. Anyone who purchased a Mitey-Mo without the new software can upgrade it by contacting Computer Devices International. **Smart 64 plus 4** retails for \$14.00.

INDUSTRY NEWS



PROMAL is a highly structured programming language now available for the Commodore 64.

PROMAL for the 64

PROMAL (Programmer's Micro Application Language) is now available from Systems Management Associates (3700 Computer Drive, P.O. Box 20025, Raleigh, NC 27619). PROMAL includes a one-pass compiler, full screen editor, command executive, and library of pre-defined utility subroutines.

PROMAL was designed for programmers at all levels of expertise. It has a fast compiler and a highly efficient run-time environment that permits applications to be written in a high-level language. The Executive (operating system) provides file, memory and programming management, and I/O redirection. A full-screen, cursor-driven editor permits rapid source program entry and editing. The library of machine language subroutines supports the run-time environment with optimized routines for file I/O, string handling, formatted output, cursor control, and data conversion. PROMAL comes with a 210-page reference manual. (For a detailed review of PROMAL, see the May/June 1985, **Commodore Microcomputers**.)

PROMAL retails for \$49.95.

Real Estate Software for the 64

Jance Associates (P.O. Box 234, East Texas, PA 18046) has released **Real Estate Investor**, for anyone considering the purchase of a home or a real estate investment. The program calculates monthly mortgage payments for conventional, adjustable, and balloon rate mortgages; mortgage amortization of principal and interest; depreciation based on the 1981 Economic Recovery Act. It also provides forecasted cash flow analysis for the life of the mortgage and income tax consequences with projected taxable income changes based on real estate ownership. The retail price is \$35.00.

Do-It-Yourself Electrical Wiring for Your Computer Outlet

After careful consideration, you find the perfect location for your computer. But what do you do if there is no outlet nearby? An extension cord is not only unsightly, it is unsafe. One answer is to add a new outlet.

A new wiring system, On-Wall Wiring, allows you to install an outlet yourself without breaking through walls and ceilings, or hiring an electrician. Basically, the system allows you to install the wire on the surface of your walls, concealing the wires in surface-mounted channels. The channel is ivory colored, but can be painted to match the color of your walls. The system also may be used to add track lighting, dimmer switches, ceiling fans, and overhead lights.

To install an extra outlet, simply tap power from an existing power source such as a wall outlet, run the wiring to the location of the new outlet via the channel, mount a fixture box, add a receptacle, and turn on the power. Of course, any project which involves working with electricity should be undertaken with care. Specific detailed instructions are enclosed in each component package and should be followed rigorously. For more information, contact the Wiremold Company, Consumer Products Division, 60 Woodlawn Street, West Hartford, CT 06110.

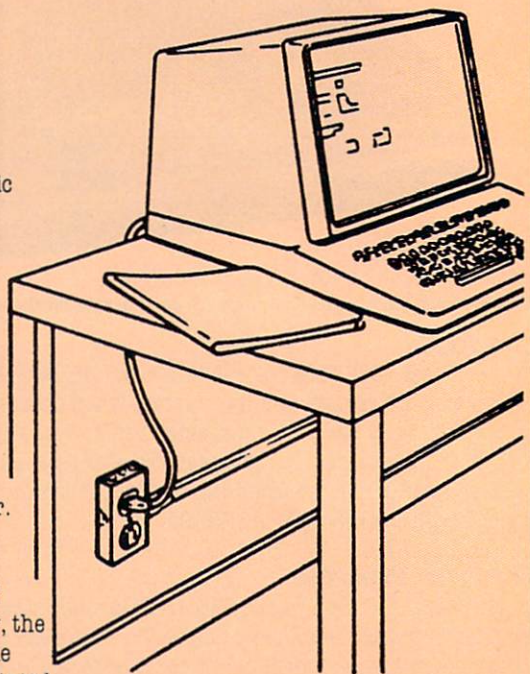

Bring power to your computer in any location.

Enhance Music Keyboard Abilities

Valhala Software (205 E. Hazelhurst, Ferndale, MI 48220) has introduced the **Keyboard Chord/Scale Master**, a program for the Commodore 64 that enhances the user's music keyboard abilities through sight and sound reinforcement. The program features chord and scale display modes, chord and scale review modes, and a compare mode. Each mode allows the users to choose up to 12 key signatures for reviewing.

Chord and scale display modes allows the student/users to view and sound the most commonly used chords and scales. The user can be challenged by learning chords, inversions, and scales from these modes. Both use three different approaches to learning: drill, quiz, and compare. The program retails for \$39.95.

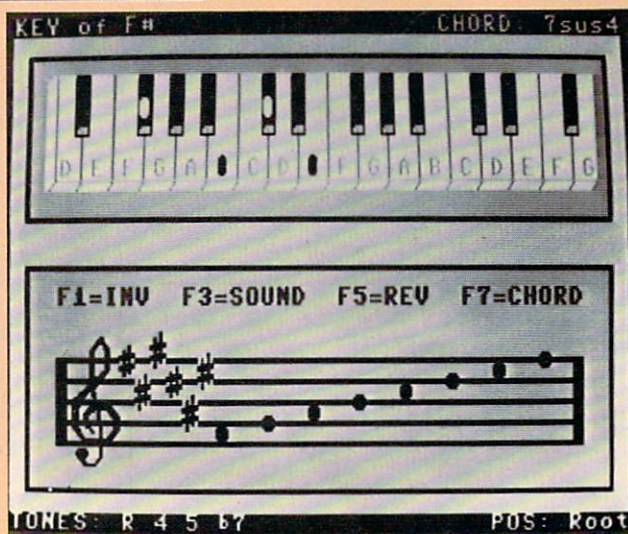

Enhance your music keyboard skills.

Music Improviser

Algo-Rhythm Software (176 Mineola Boulevard, Mineola, NY 11501) has released **Cantus**, a disk-based program for the Commodore 64 that actually invents its own music.

The program was created by Michael Riesman, a composer and performer best known for his work as musical director of the Philip Glass Ensemble. Instead of typing in notes, the user enters tempo, harmony, rhythm, counterpoint, voice range, and tone color, which becomes the basis from which **Cantus** creates, in real time, its three-voice improvisations.

Each set of user choices becomes a "patch," which can be saved to disk, and recalled and played at will. The program comes supplied with over 65 such patches, representing a broad range of musical styles. Any patch can be modified and stored as a new patch.

No musical knowledge is required to operate the program. There is a 48-page manual which includes a glossary of musical and technical terms. Retail price is \$54.00.



Horse Racing and Bet Return Analysis Software

Software Exchange (2681 Peterboro Road, P.O. Box 5382, West Bloomfield, MI 48033) has released horse racing handicapping software. Three programs, accessed by menu selection, make up the package, including **Thoroughbred Racing Analysis**, **Harness Racing Analysis**, and **Bet Return Analysis**.

The handicapping programs analyze past performance data taken from the racing form and predict the outcome of each race. The programs for the VIC 20 and Commodore 64 are supplied on disk or cassette, and include a complete set of instructions. It retails for \$29.95.

Astronomy Software

An annotated list of astronomy software for home computers has been published by the non-profit Astronomical Society of the Pacific. Each listing contains a brief description of what the software does and the full address of the manufacturer. A list of reference books is also included. Copies are being made available as a public service by the 97 year-old Society. To obtain a copy, send a donation of \$1.00 to cover postage and handling costs to Astronomical Society of the Pacific, Computer List, 1290 24th Avenue, San Francisco, CA 94122.

More News on page 126



**IT'S NOT
HOW LITTLE IT COSTS,
IT'S HOW
MUCH YOU GET.**



We have a surprise for all those people who think that in order to get more you have to pay more.

The Commodore 64.™

We also have a surprise for all those people who think they have to settle for less just because they're paying less.

The Commodore 64.

The Commodore 64 has a full 64K memory, high fidelity sound and high resolution, 16-color sprite graphics.

It's fully capable of running

thousands of programs for schools, business or funny business.

But the Commodore 64 is about one third the price of the 64K IBM PCjr™ or the Apple IIe.™ In fact, for about the price of those computers alone you can get the Commodore 64, a disk drive, a printer and a modem—a powerful computing system.

We don't do it with mirrors, we do it with chips. We make our own. So we can make them for less, more efficiently and more

economically than people who don't. (Which is just about everybody else.)

So because it's a 64, it's powerful. Because it's a Commodore, it's affordable. And because it's a Commodore 64, it's the world's best selling computer.

COMMODORE 64

IT'S NOT HOW LITTLE IT COSTS,
IT'S HOW MUCH YOU GET.

Write Now/ Spell Now/ File Now/ Calc Now/ Mail Now

Computer: Commodore 64
Publisher: Cardco
 300 S. Topeka
 Wichita, KS 67202
Medium: Disk (*Write Now*
 cartridge)

After establishing itself as a leading peripheral manufacturer, Cardco has expanded to encompass home and small business productivity software. Each program is designed to interface with others, providing a comprehensive word processor, spelling checker, file system, data base and mailing list from which users can mix and match.

The anchor program in the series, *Write Now*, is an easy-to-use and versatile word processor. The cartridge comes packaged with a cardboard overlay for use over the number keys. The overlay is a bit bulky and has to be taped on, so most users will probably prefer to keep it near the computer instead of on it.

Write Now includes most standard word processing functions, including search-and-replace, tabs, a buffer which holds up to 255 characters, and underlining. The only thing missing is an automatic title-centering option. Although the program doesn't display the sort of options menu other Commodore 64 word processors use, the overlay takes care of commonplace commands.

Some nice options missing from other word processors have been put into this one. For example, at the start of each session, the user selects screen and text colors, choosing the one that is most comfortable. Underlining is available, providing your printer permits it. And users can tailor paragraph indents, dot commands, and margins to suit their needs.

Unlike some word processors' text display, *Write Now* doesn't automati-

Beginners who want to expand their computer's capabilities without having to learn new data entry systems will appreciate Cardco's modular approach to home productivity software.

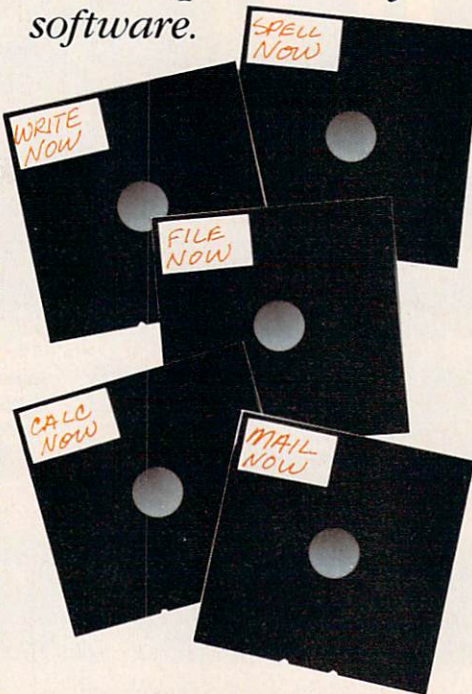

cally keep complete words together at the end of each line. Though the instruction booklet points this out and assures users that all disconnected words appear correctly when printed out, it's still disconcerting to see "we" at the end of one line and "ather" at the start of the next.

The documentation is pretty straightforward and its familiar tone keeps first-time users from feeling intimidated.

Spell Now is a disk-based spelling correcter, used in conjunction with a file created by *Write Now*. After completing a document, writers can use it to check spelling against the program's 34,000 word dictionary, 1,000 word mini-dictionary, or an unlimited number of files created by the user. As in *Write Now*, the enclosed documen-

tation painlessly guides first-timers through each step of the file-creation and checking procedures.

Filing hassles are streamlined with *File Now*, which functions as a deck of 3" by 5" index cards on disk. Up to 700 individual cards can be stored per disk, added to, edited, and used by themselves, or as part of a larger *Write Now* or *Mail Now* file. The user defines each category in a file, and the program can search out cards according to any category listed on a card.

In *Mail Now*, address files can be retrieved according to last name, state, zip code, or category, then printed out as mailing labels (sorry, it doesn't do envelopes) or as part of a form letter. Each category is listed in a two-character directory, which, along with a ten-character comment line, can be printed on the mailing label or saved without printing.

The final program in the set, *Calc Now*, offers a versatile, *Write Now*-compatible spreadsheet starter set. Users are allotted 39K of free memory for data files, which can be displayed in up to 64 columns and 254 rows. Each column width is variable and must be set by the user. Of course, *Calc Now* can be used to create charts and grids for documents written with *Write Now*, but mathematicians will appreciate its wide range of functions, including sine, cosine, tangent, arc-tangent, log base 10, e to the x, and square roots.

Grids created by *Calc Now* can be printed in their entirety, or portions can be selectively reproduced. A built-in scratch pad calculator makes small computations a snap and windows can be set to horizontal or vertical positions.

Each disk in the series is protected by a lifetime guarantee against disk failure (not including, of course, burns, spilled coffee, or other owner-inflicted damage).

The Cardco series offers something to everyone. While no single program outshines its competition in all areas, the entire package works well together. Beginners who want to expand their computer's capabilities without having to learn new data entry systems will appreciate Cardco's modular approach to home productivity software. C

BATTERIES INCLUDED



"The Energized Software Company!"

We started with Commodore, designing programs that quickly became industry success stories. Now we're moving on, applying our expertise to other systems.

Look for Apple, Atari, IBM, and Commodore software with the Batteries Included label!



"The best Atari word-processor ever."
ANTIC MAGAZINE



"... capable of very large and complicated searches ... a very good system."
TPUG MAGAZINE



"Performance: excellent...
Error-Handling: excellent...
Value: excellent"
FAMILY COMPUTING
(a "Billboard" magazine
#1 best seller)

Look forward to excellence, in every respect. Power and performance, ease of use, incredibly low prices, for programs that help you in so many ways.

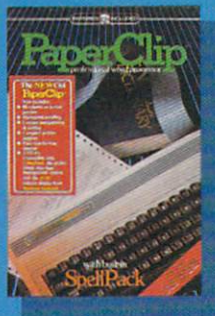

Also from BATTERIES INCLUDED:

CalKit: problem-solving spreadsheet program with built-in templates for the most-needed home and business applications — including income tax, budgets and many more.

B/Graph: professional-quality graphics/charting and statistical analysis package turns your data into superb visuals.

Sales Force: professional sales management and reporting program saves you valuable hours.

"Keys To Typing": easy to follow tutorial program typing teacher.

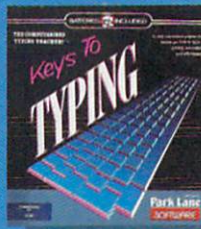

"quite simply the best ... the highest rating possible."
ANALOG COMPUTING

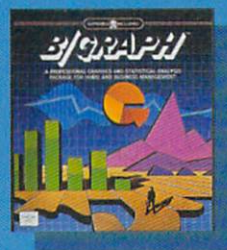

"Literature Challenge — Introduction To Shakespeare": learn about the bard's three most-taught plays — and have fun! (Other authors on the way.)

B.I.-80 Column Display: add-on module doubles your screen capacity and improves visibility.

HOME ORGANIZER SERIES home database managers. (8 programs including Home Inventory, Recipes, CheckBook, Address Book, Audio/Video Catalogue and more)

BATTERIES INCLUDED



"The Energized Software Company!"

30 Mural Street
Richmond Hill, Ontario
L4B 1B5 CANADA
(416) 881-9941
Telex: 06-21-8290

17875 Sky Park North, Suite P
Irving, California
USA 92714
(416) 881-9816
Telex: 509-139

WRITE TO US FOR FULL COLOUR CATALOGUE of our products for COMMODORE, ATARI, APPLE and IBM SYSTEMS.

FOR TECHNICAL SUPPORT OR PRODUCT INFORMATION PLEASE PHONE (416) 881-9816.

SOME PROGRAMS ARE NOT AVAILABLE FOR ALL SYSTEMS.

Commodore, Apple, Atari and IBM PC are registered trademarks of Apple Computers, Inc., Atari, Inc., Commodore Business Machines, Inc., and International Business Machines, respectively

Kwik-Write

Computer: Commodore 64
Publisher: Datamost
 19821 Nordhoff Street
 Northridge, CA 91324
Medium: Disk

K*wik-Write* is an inexpensive full-function word processor that combines ease of use, remarkable speeds and features found in many more costly word processors.

The program loads in 33 seconds. The main menu offers eight choices from create to print, and can be accessed from any point in the program. This is very handy, especially when you want to cancel a format-disk command, or abort a printout.

You are presented with a 22-line 40-column screen with a two-line status box. The status box provides the number of characters free (you begin with 34,545, or roughly 16 double-spaced pages), the file name, cursor column, main menu access, and help.

The program automatically word-wraps, carrying over any word that won't fit at the end of one line to the start of the next. Editing as you write is effortless. To insert a word or paragraph, merely activate the insert mode by pressing SHIFT/INST.

But you're not limited to working in 40-column mode. You can "stretch" the screen to as many as 132 columns, though you can view only 40 at a time. As you type, the screen moves laterally. This may make some users a bit dizzy, so I suspect that most will stick to the 40-column mode, unless they're setting up a structured format like a letter. To set up numeric data, you must align it manually, since there is no TAB function.

You can format a disk from within the program in 14 seconds. Select "Save" from the main menu and name your file. If you're updating a previously created file, hit RETURN and the new file replaces the old. A directory option in the main menu tells you what's on each disk and how many blocks are free. Save a file of 4,000 words in 46 seconds and load the same file in 23 seconds.

Before printing your document,

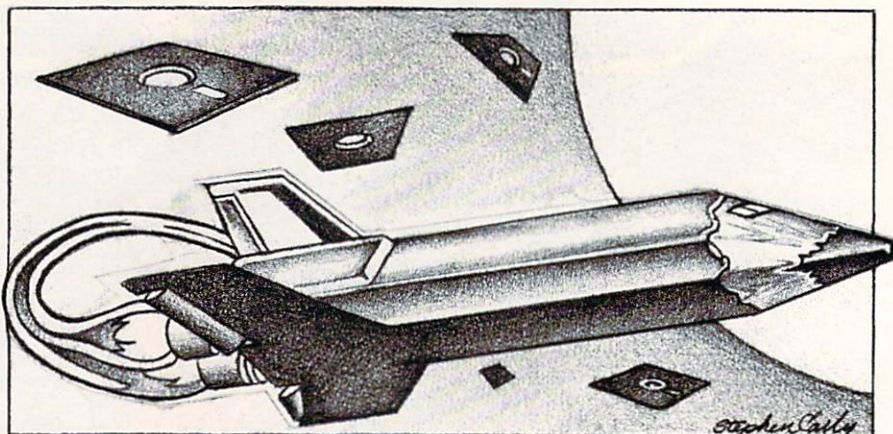

For computer users seeking a simple, yet powerful, word processing program, Kwik-Write is worth a closer look.

you usually want to view it. With its print-to-screen option, *Kwik-Write* theoretically views up to 132 columns, 40 at a time. Unfortunately, however, the side scroll doesn't glide, it jumps, more like a slide show. As a result, it's virtually impossible to read a document in the print mode. The best alternative is to monitor line and page breaks here, instead.

In order to print to paper with *Kwik-Write*, you must create your own prompts. Set up a print command menu on the first line of your file with such codes as Command "S" (for spacing) and "L" (left margin) with a number after each. There are defaults, but if you forget to enter one while printing single sheets, your printer will continue to print as you scramble to feed it another sheet. You also must remember to put in a code for the header, footer and paragraph indents.

For special print commands, *Kwik-Write* offers only underline—no italic, bold, super- or subscripts. You can adapt the program to various printers with a "printer driver" option. I used the program on a daisy wheel and dot matrix printer and it worked flawlessly on both.

The Features

Kwik-Write will center, justify left and right, print "block-right" (ragged left margin), and offer half-line spacing and variations of print blocks. It will also merge files from disk, verify saves, re-name and scratch files, all from within the program at exceptionally fast speeds.

You can merge word processor text with a data base or mailing list. You can also chain files. There is a 30,000-word spelling checker, *Kwik-Spell*, available.

Some of the more sophisticated features of this powerful little no-nonsense program include search-and-replace, a standard ingredient in most expensive word processing programs, but not one you'd expect to find in the "budget" class. Type the word or phrase (up to 38 characters) you wish to search for ("wild cards" are permitted). If you want to replace this text, F4 allows you to key in the new copy.

Equally fast and effortless are the cut-and-paste, and "boiler plate" features. Here, highlight text with F5, copy it into buffer memory with F6, imbed it somewhere else with F7, or delete it with F8. You can drop it in as often as you like, within limits of available memory, of course.

If you've deleted text that you wish you hadn't, you can get some of it back. You can also recall with a command the last letter you deleted. This doesn't sound like much, but it can be useful. Since that same letter will keep printing for as long as you hold down the command keys, you can use this option to print a long string of similar characters. *Continued on page 20 (Bottom)*

Lifestyle

With the Lifestyle Series from Commodore, you can put yourself in the position of an astrologer, artist, or gourmet chef and let your imagination run wild.

Are you intrigued by the wonders of the zodiac? **Micro Astrologer** will show you how your birth-date affects your personality, career, love life and more. Loads of fun for the entire family!

Exhibit your creative flair with **Micro Illustrator** and design all kinds of cartoons, patterns, and pictures. The perfect

way to utilize the excellent graphics capabilities of the Commodore 64.

Prepare a variety of tempting dishes with the help of **Micro Cookbook** and end the confusion of all of those dog-eared recipe books. Comes complete with **two diskettes** and over 150 of the world's favorite dishes to whet your appetite.

So when you feel the pressures of your day-to-day life beginning to close in on you, take a break . . . and enjoy the lifestyle of Commodore.

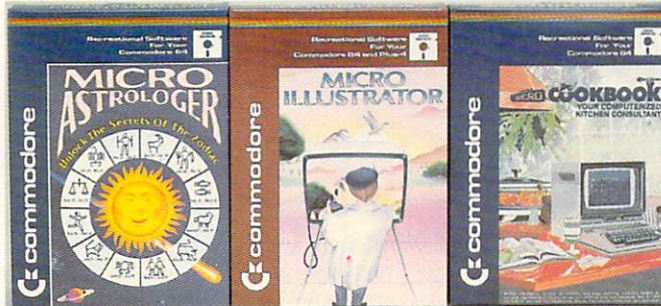

suggested retail price **\$19.95**

suggested retail price **\$29.95**

suggested retail price **\$34.95**

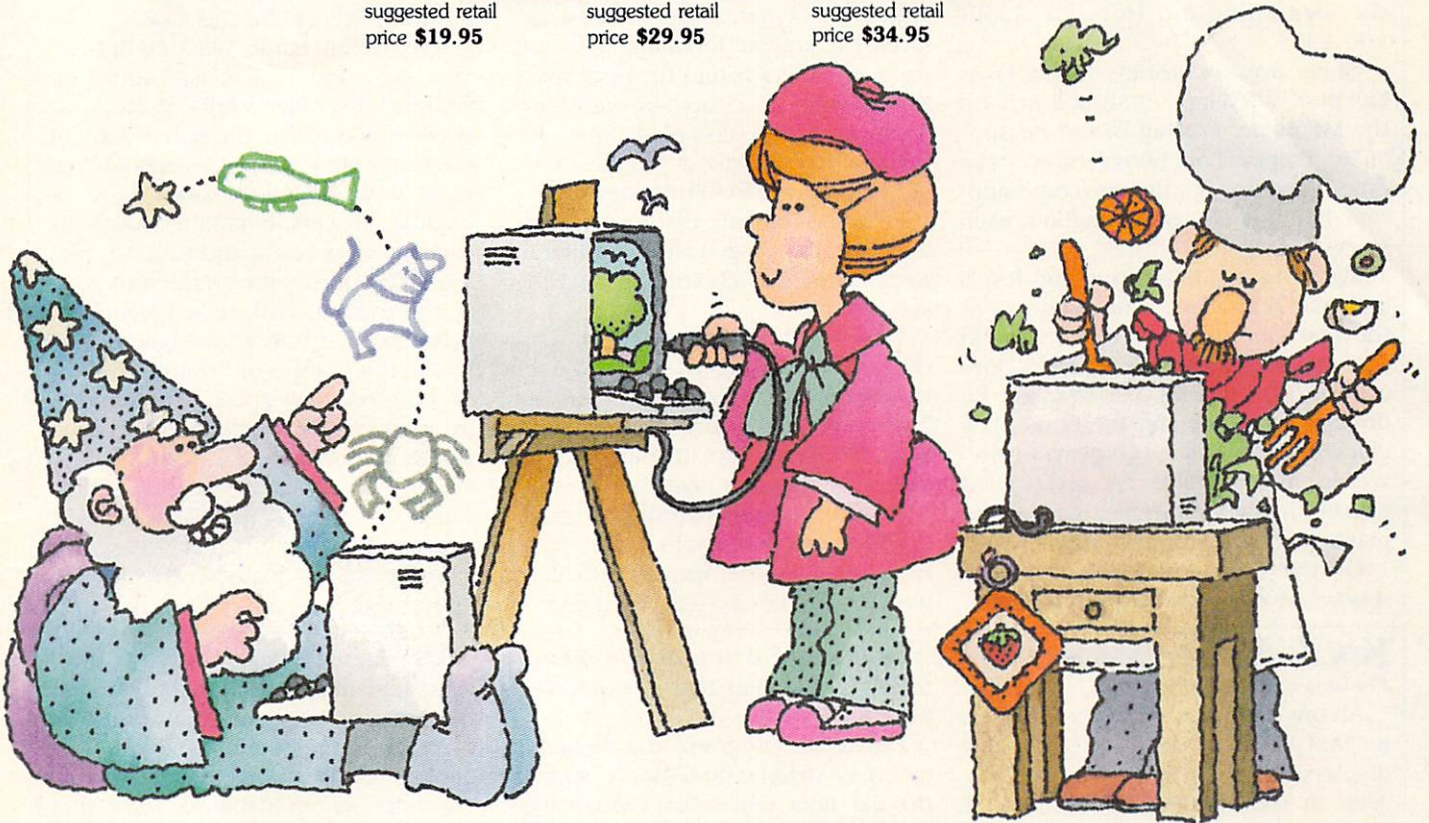

COMMODORE

RECREATIONAL SOFTWARE

All three products are diskette based and are available on the Commodore 64.
*Micro Illustrator is also available on diskette for the Commodore Plus/4

Right Again!

Computer: Commodore 64
Publisher: Ascension Designs
 6108 N. Western
 Oklahoma City, OK
 73118
Medium: Disk

It is difficult to find religious educational software, and when you do find it, it is often inadequate. Ascension Designs has provided one that is both educational and fun: *Right Again!*

A colorful storybook comes with the game, and biblical quotations are taken from the New International Version of the scriptures. Included in the back of the book are three maps of Bible lands, a listing of the Old and New Testament books, and a timeline from the beginning of time to about 100 A.D.

There are six stories: "God Likes Me Best," "Giants," "Showdown on the Mountain," "King of the Beasts," "The Empty Lunchbox," and "The Empty Grave." A value for contemporary living is woven throughout each story.

Right Again! has three clue levels and two skill levels. The solutions to the first clue level are referred to in the storybook. The second-level clues are from the stories, but may not be directly mentioned in the book. The clues in the third level come from anywhere in the Bible. A red-headed cherub named Dominic directs the player through the clue screens.

Of the two skill levels in *Right Again!*, level two is the most difficult.

A value for contemporary living is woven throughout each story.



When you get to the "guess" part of the game on the second level, you must be able to spell the object on your own, whereas on the first skill level, the angelic Dominic will write the correct letters into the right spaces as you type. In either skill level, you must accurately complete four clues before you can make a "guess."

The clues are in four categories: *Charade*—"Person, Place, or Thing?" and "Animal, Vegetable, or Mineral." Each incorrect choice subtracts 50 seconds.

Library—A librarian travels on a ladder across the screen. Old Testament books are on the lower shelf and New Testament books are on the upper shelf. The books are arranged according to categories like law, history, literature, minor prophets, major prophets, gospels, Paul's letters, pastoral letters, and the Apocalypse. As the librarian moves across the shelves, a

book is tossed out, and Dominic moves to catch it. If he succeeds, a clue is flashed on the screen. You are also informed if you have the right book, or, in which section the right book may be found. Dominic must catch the right book before you can give an answer to this clue.

Map—A flying Dominic moves anywhere on the map you choose. If you are "hot" on the clue, an audio tone beeps rapidly, but if you are on a "cold" trail, it beeps slowly. When you get to the right location, Dominic can still get lost.

Time—For this clue, move Angel Dominic to different time periods shown on the screen. A person from that period tells you what is known about the clue, if anything. If you need to know more, it costs you 50 additional seconds on the time-clock for each hint. Dominic must visit the right time period for this clue.

I used this game with eight-to-16 year-olds, and college-age adults, as well as with older adults. Each group was excited about the game and the level they chose. The 15 year-olds and older were impatient waiting for the loading process between clues, but each age was ready and eager to play when the clues came on the screen.

The musical fanfare is a delightful accompaniment to *Right Again!*. And Dominic's gesture of "thumbs down" on an erroneous guess, accompanied by an electronic sound reject, encourages better choices.

This biblical trivia game is an educational challenge, as well as an inexpensive tool for further discussion about religious values and biblical knowledge. **C**

Kwik-Write

Continued from page 18

An unusual feature of *Kwik-Write* is its "ASCII I/O mode." The status line displays the ASCII code for the character at the cursor position. In this mode, work on almost any type of file, including machine language. This is especially useful for programming purposes.

You can also type entirely in uppercase letters without using SHIFT LOCK, or change cases up and down with the English pound sign and a combination of command keys. This

can be useful if you decide midway through your text that it would look nicer all in caps.

Unlike the program, the documentation is strictly no-frills. A 20-page manual tells you what each feature does and how to access it. Period. The last two pages contain edit and print command tables. These pages will get a rigorous workout until you commit them to memory. However, since the commands are relatively few and involve essentially only two escape keys (C and CONTROL), it shouldn't take long.

The documentation doesn't, however, explain some of the more arcane functions of the program, such as mail merging or creating a data base. Nor does it tell you how to use the four character sets available, or what they look like.

Nevertheless, *Kwik-Write* is a versatile word processing program that will not only turn out an occasional letter, but perform admirably in more serious applications. For computer users seeking a simple, yet powerful, word processing program, *Kwik-Write* is worth a closer look. **C**

TAKE A BREAK!

For
Commodore 64™
Computers

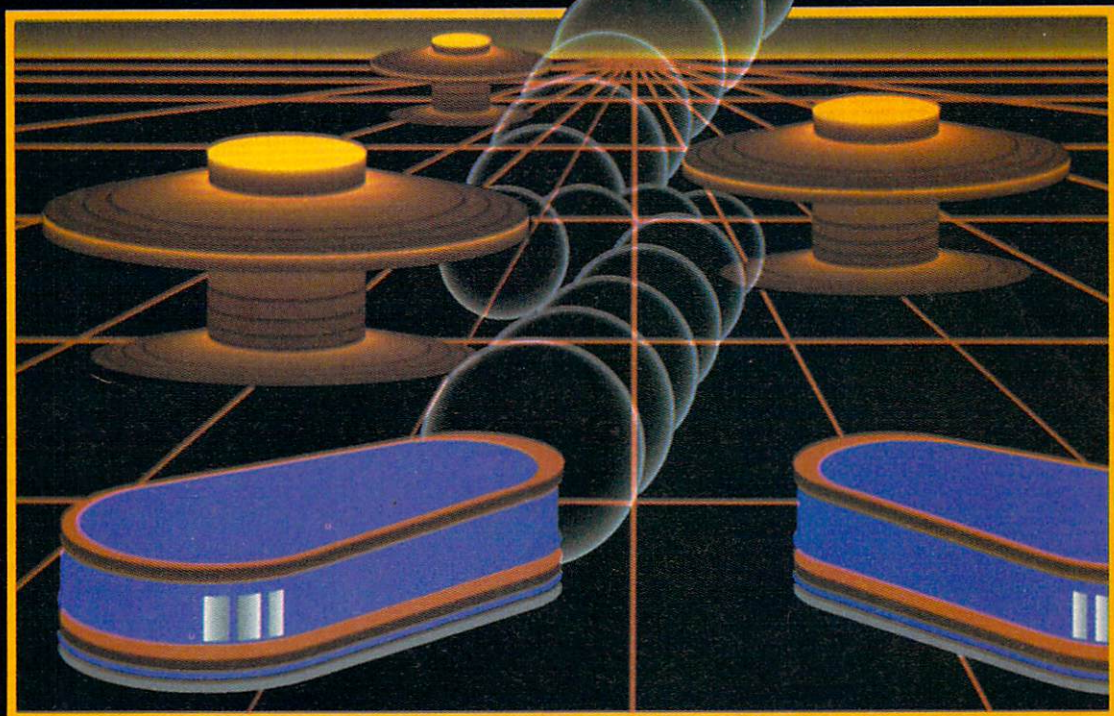

WITH NIGHT MISSION **PINBALL**

You deserve the best. You've earned it. Now reward yourself with a session of **Night Mission PINBALL**, the most realistic and challenging arcade simulation ever conceived! ■ Stunning graphics and dazzling sound effects put **Night Mission PINBALL** in a class by itself. Game features: multi-ball and multi-player capabilities, ten different professionally designed levels of play, and an editor that lets you create *your own* custom modes. ■ So take a break with **Night Mission PINBALL** from SubLOGIC. Winner of *Electronic Games* magazine's 1983 Arcade Award for Best Computer Audio/Visual Effects.



See your dealer . . .

or write or call for more information.

Order Line: 800 / 637-4983

subLOGIC

Corporation
713 Edgebrook Drive
Champaign IL 61820
(217) 359-8482 Telex: 206995

PFS:Report

Computer: Commodore 64
Publisher: Software Publishing
 1901 Landings Drive
 Mountain View, CA
 94043
Medium: Disk

P*F*S:Report takes the "raw data" stored by Software Publishing's *PFS:File* database manager and redirects it so it can be displayed in a more refined—and useful—manner. Please note that *PFS:Report* cannot be used alone. You must use *PFS:File* first to initially store information. *PFS:Report* is simply a tool to mold the information saved by *PFS:File*. You can use *PFS:File* without using *PFS:Report*, but you can't use *PFS:Report* without using *PFS:File*.

How does *PFS:Report* differ from *PFS:File*? *PFS:File* displays all data fields in the same format (via report screens and attachment screens). When you request a report which satisfies a condition (phone numbers within the 212 area), not only will that data be displayed, but all the data fields associated with that data record. This may result in obtaining *too much* unorganized data.

PFS:Report organizes your data so that only desired fields will be displayed. Although the program can display data fields (item numbers) directly on your CRT, it clearly lets you take advantage of 80-column hard copy.

The program prints your data in tabular reports composed of a vertical column for each field on your *PFS:File* data disk. Thus, each vertical column corresponds directly to one item name. To picture this better, imagine a data base containing three records, each with five fields:

	RECORD A	RECORD B	RECORD C
ITEM #1 is person's last name:	Jones	Smith	Jones
ITEM #2 is person's first name:	John	Bob	Kathy
ITEM #3 is person's phone number:	234-1924	111-2984	624-9874
ITEM #4 is person's age:	37	29	21
ITEM #5 is person's gender:	male	male	female

Thus, a *PFS:Report* printout of every In the event that there were two or

PFS:Report has a number of features which will tame even the wildest data base.

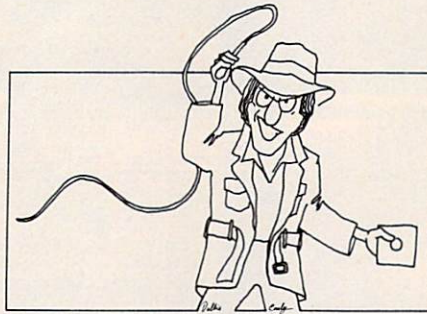

item and report in our file would look like:

NAME OF REPORT (specified by user)

LAST NAME	FIRST NAME	PHONE NUMBER	AGE	GENDER
Jones	John	234-1924	37	male
Jones	Kathy	624-9874	21	female
Smith	Bob	111-2984	29	male

As you can see, data reports are automatically put in columns and listed in alphabetical order as specified in column one (last name) and column two (first name).

A second example illustrates how *PFS:Report* can produce a report which displays partial record information (age, first name, last name). The report is automatically sorted numerically (greater to lesser) in column one by age:

AGE	FIRST NAME	LAST NAME
37	John	Jones
29	Bob	Smith
21	Kathy	Jones

more people with the same age, *PFS:Report* would have performed a secondary sorting routine based upon data found in column two.

As in *PFS:File*, there are five standardized ways to specify a search: full item match, partial item match, numeric item match, numeric range match, and not-match. This powerful feature has been retained and further illustrates the power of integrated software.

My example file was simplistic. In real life, data files can often become unmanageable simply due to size and configuration. *PFS:Report* has a number of automatic features which will tame even the wildest data base. These features include automatic report title centering, alphabetical or numeric sorting, automatic decimal point alignment, calculated columns and automatic page numbering.

Column headings can be a direct pickup of the item name (as estab-

lished in *PFS:File*), or can be redefined using the "Set New Headings" mode, which is a subroutine accessed from the main menu. For example, you may have originally given field "X" the name, "Selling Price to Customers." When initially entering data through *PFS:File*, this long-winded title may have helped you remember the purpose of this field. However, a column heading such as this would occupy too much physical space on an actual report. The "Set New Headings" mode allows you to shorten/change this field name ("Your Price").

Besides the actual print mode, there is one last mode found on the main menu. This is the "Pre-Define A Report" mode. This mode allows a user to set up the print parameters for up to eight different reports. Although the actual specification of a report format is extremely easy, this mode will allow the user to finely tune any frequently used report to personal standards.

There are three more features which make *PFS:Report* an outstand-

Continued on page 24

Flight Simulator II

For Commodore 64™
Computers



Put yourself in the pilot's seat of a Piper 181 Cherokee Archer for an awe-inspiring flight over realistic scenery from New York to Los Angeles. High speed color-filled 3D graphics will give you a beautiful panoramic view as you practice takeoffs, landings, and aerobatics. Complete documentation will get you airborne quickly even if you've never flown before. When you think you're ready, you can play the World War I Ace aerial battle game. Flight Simulator II features include ■ animated color 3D graphics ■ day, dusk, and night flying modes ■ over 80 airports in four scenery areas: New York, Chicago, Los Angeles, Seattle, with additional scenery areas available ■ user-variable weather, from clear blue skies to grey cloudy conditions ■ complete flight instrumentation ■ VOR, ILS, ADF, and DME radio equipped ■ navigation facilities and course plotting ■ World War I Ace aerial battle game ■ complete information manual and flight handbook.

See your dealer . . .

or write or call for more information. For direct orders enclose \$49.95 plus \$2.00 for shipping and specify UPS or first class mail delivery. American Express, Diner's Club, MasterCard, and Visa accepted.

Order Line: 800 / 637-4983

Circle Reader Service No. 26

subLOGIC
Corporation
713 Edgebrook Drive
Champaign IL 61820
(217) 359-8482 Telex: 206995

ing product. The first allows you to create reports by specifying a *keyword*. A keyword is any word which is used to identify and sort a report. For example, let's say you have a video tape collection data file. Assume field one contains the tape ID, field two contains the name of the movie, field three contains the index counter numbers, field four contains the duration time, and field five contains a variety of description keyword "pointers" which will help categorize the movie. Using *PFS:Report*, you can print out all titles according to a subject keyword, which will serve as the sorting mechanism as well.

The second great feature is that the program automatically prints out totals, subtotals, averages, sub-averages, numerical counts, and sub-counts for any specified column. For example, in an inventory situation, use *PFS:Report* to give an average of all profit margins, counts of all inventory names, and totals of all units of merchandise—automatically. This feature can be appreciated by anyone who has ever managed even the smallest retail operation or distributorship.

The third major feature of *PFS:Report* is its ability to create up to three derived columns. A derived column is a data field synthesized from user-supplied formulas. The user simply "plugs in" a mathematical formula and directs that formula to be visible (to be printed in the report), invisible (not to be printed on the report but used for sorting and/or a base for a derivation), or to be applied to previously derived columns.

A derived column does not have to correspond to a field in the original data base, as do other report columns. A derived column is fundamentally a numerical manipulation of numbers contained in other columns. For example, let's assume that I own a record store and have set up a data base using *PFS/File*. My data base contains titles, authors, publishers, suggested retail price, and net price. Using derived columns, I can have *PFS:Report* calculate internally a 45% markup on all titles (customer price), calculate savings off of the suggested list price, and calculate percentage off the regular full price. The savings in time—and increased accuracy—will justify *PFS:Report* to any small business

For a low-cost report generator and calculator all rolled into one, this product is unique and impressive.

person.

To conduct a test, I set up a fictitious, but viable, business situation: Using *PFS/File*, I assigned each product in my "inventory" a unique report number. I set up item name (field) categories for machine used/application, ID code, title of product, publisher, supplier, my net costs, suggested list price, and general comments.

I closed my data file and loaded *PFS:Report*, creating a "pre-defined" report format. Next, I specified my sort columns as one and two. Column one contained the machine/application, and column two contained the title of the product. Column three contained the manufacturer's suggested list price. Column four contained my cost.

I defined columns five, six and seven using the derive option, since these three fields do not exist in my original "real" data base. Column five would be my selling price (20% markup). I named this new column "20%MU." I next assigned the formula: $\#4 + (\#4 * .20)$ to this column. The formula means "take the numerical quantity found in column four (cost) and add it to the product of column four multiplied by .2 (or 20%)."

Derived columns are restricted to five easy rules, and utilize the standard mathematical symbols plus previously established column numbers (#X). Column six became my dollar profit on each item. I set up the derived column with the formula: $\#5 - \#4$. This means "subtract my buying net price from my selling price." I named this column, "PROF," for obvious reasons.

Column seven became "%DIS,"

short for customer percentage discount. (It's helpful for ad managers to know what percentage off list a customer is saving.) My formula was: $100 - ((\#5 * 100) / \#3)$. This is a standard ratio formula where column three represents full list price (or 100%), and column five is my selling price. The result of this ratio was subtracted from 100 to give a percentage-off list.

Column seven is important because it spotlights two additional concepts when working with derived columns. Column five—a previously derived column—is used as a basis for column seven's subsequent calculation, and floating point numbers (those with decimal points) are automatically rounded off.

PFS:Report quickly produces a report I can use in my imaginary "business." It first selects forms which satisfy search mode parameters, if any. It then sorts the selected fields alphabetically or numerically. Now *PFS:Report* truncates the report when a report is more than 80 characters wide for printers, or 40 characters wide for monitors. Then it prints your report, automatically numbering pages and spacing the columns.

You are allowed to print up to 20 vertical columns using *PFS:Report*. However, there is no way to physically display that much information in an 80-column space. I have found that (realistically) the maximum number of columns that can be printed is approximately two alphanumeric columns plus five numeric columns. Any more information would literally push the data off the page.

If *PFS:Report* performs a derived calculation on a report where the supporting columns are blank (or contain a blank field crucial to the derivation), a mathematical error is produced. *PFS:Report* also doesn't give the user control of numerical accuracy via the decimal point. An "INT" function would be helpful in the event that preset default values proved unsatisfactory in specific user situations.

I'm glad to be an owner of this product. I know that *PFS:Report* will extend my effectiveness in the home and at work. For a low-cost report generator and calculator all rolled into one, this product is unique and impressive.



New 128 news

If you've ordered the new Commodore 128™ or you're thinking about it, Sams has news for you! A new book: The first and only official guide to Commodore's exciting new business computer.

Now you can read all about the Commodore 128 and its three different operating modes—64™, 128, and CP/M®. You'll learn how to use spreadsheets, and word processing, choose peripherals, create graphics and animation, run CP/M programs, and more.

Best of all, you'll learn how the 128 can work for you at the office or at home. So whether you've already ordered the 128 or are getting ready to, you'll find Sams Official Guide a wise investment.



Get the book that's making headlines. Get Sams Official Commodore 128 book. Visit your local Sams dealer. Or call our toll-free number and ask for Operator 150.

The Official Book for the Commodore 128 Personal Computer, No. 22456, \$12.95.

800-428-SAMS

In Indiana, call 317-298-5566

SAMS

Howard W. Sams & Co., Inc.
4300 West 62nd Street
Indianapolis, IN 46268

HomePak

Computer: Commodore 64
Publisher: Batteries Included
 30 Mural Street
 Richmond Hill, Ontario,
 Canada L4B 1B5
Medium: Disk

Want to stretch your purchasing power? Consider HomePak, the compact three-in-one package that includes word processing, a data base, and telecommunications, all for an affordable \$49.95.

HomeText

Most word processors offer sophistication, versatility and convenience. But, sometimes the extras are what determine the program's ultimate appeal.

Stop, for a moment, to consider the simple sound of a key click. Are you, at times, uneasy with a computer's stoic silence? Then you'll appreciate the optional synthesized key click sound in *HomeText*—a welcome, even friendly, intrusion signalling a typed character has been accepted. More practically, the key click may be particularly appealing to touch typists, who are accustomed to hearing the rhythmic staccato of the typehead smacking the paper.

Windows are another appealing feature. The format and text block menus, for instance, are overlaid (temporarily of course) on your working screen. This is a novel solution allowing the screen's contents to remain visible during text handling.

F7 summons the text block-handling functions such as move, delete, copy and find/replace. F3 summons the window displaying all format options, and I do mean all. There are more than 20 choices, including margins, line spacing, justification, and special print instructions. All operations are invoked simply by responding to the on-screen prompts.

Text is entered via the self-explanatory insert or replace (overtyping) modes. Toggling between these two with the F1 key also causes the screen's border to change color, a graphic reminder of the mode you are in.

By offering three innovative, versatile programs, HomePak gains a competitive edge: an unbeatable combination at an irresistible price.

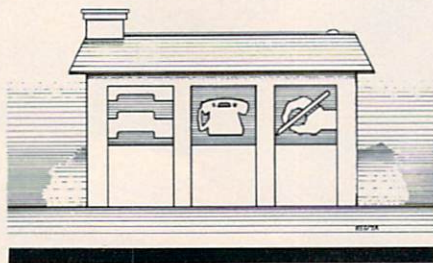

Text movement control keys are arranged spatially, corresponding to the desired text movement direction. For example, the "Q" and "W" keys move the text/cursor up; the "Z" and "X" keys, down; "S" and "D" shift the cursor horizontally.

Total document length is limited to the 13.5K buffer (about 14 screens). But by following the directions in the main (F5) menu for merging subsequent files, longer documents can be sequentially printed.

Three special printer features are supported: underline, bolding and extended. The main menu's configure-printer function embeds your printer's control codes in a permanent utility file. Although you can't change the menu's description, you can readily change the printer's responses. For instance, I substituted italics for extended by simply changing *HomeText's* embedded codes.

Another printing function, preview, is exceptionally effective. Instead of actually reeling through readable text on-screen, *HomeText* depicts a schematic representation of the printed page. Line spacing as well as special formatting features are graphically portrayed.

One frustrating bug surfaces when using the INST/DEL key to erase characters in the insert mode. After erasing approximately ten characters, the cursor occasionally jumps to the beginning of the text.

HomeFind

Data bases generate considerable interest, and for excellent reasons, too. If you have quantifiable information about anything worth remembering, and if you've a memory like most—already overloaded—just remember your facts long enough to get them into *HomeFind*.

Data bases come in various configurations. *HomeFind* is a free form, non-relational data base. This means that *HomeFind* has a non-rigid structure, so you're not confined to predefined "fields" or specific information categories. Rather, catalog your information in a natural, almost random, fashion.

Each sentence, or topic, is broken into three parts: subject, tag, and object. An example: My dog's nickname's Lunatic. The apostrophe s ('s) is the key to the data base's recognition. When the parser sees an 's, it separates the statement at that point and files the information as either the subject (first), tag (second), or object (last). Numerous variations are permitted so multiple references are possible. Information is retrieved by asking questions again, in conversational English, like "Who is a lunatic?" (my dog) or "What is my dog?" (a lunatic).

Naturally, I wouldn't need a data base just to remember my dog's nickname (his behavior is reminder enough). But a data base is a timesaver when cataloging events, addresses, people, dates, descriptions, or anything else you can compile into a list. The key concept is list. If you can list your information, then an effective data base can later locate that data.

The free form of data entry imposes some requirements for rationally organizing the information before you start typing. Without this prior planning, some retrievals may be humorous, but, at times, incomprehensible. Also, since *HomePak* is non-relational, the changing of data in one statement will not automatically update any other references to the same subject or tag.

Incidentally, in keeping with this informal protocol, the program's chatty responses such as, "That's news to me," "Thanks" and "Never mind" are a refreshing respite from a computer's usual rigid syntax.

HomeTerm

HomeTerm telecommunications software offers file transfers via standard ASCII, Commodore PET ASCII, CompuServe Vidtext, and even Xmodem protocol (supported by most CP/M systems). Files can be routed to disk, screen (default), or printer.

Some of *HomeTerm's* other highlights include the following:

- An edit window enables you to first compose, then correct, data before uploading to the host computer.
- Function key menus offer a choice of full- or half-duplex transmission, file translation, and 300/1200 baud rate selection.
- An on/off capture buffer toggles so incoming data can be selectively saved or ignored.
- A complete disk management submenu (similar to Commodore's wedge) provides file or disk copying, file deleting, formatting, initializing, and renaming.
- Sequential Macro commands.
- Up to nine separate configuration files. Each conveniently stores different macros, for sign-on ID's or baud rates.
- Real time clock.
- Optional word wrap.

If all this seems like a lot to remember, you're right. *HomeTerm* is understandably complex because it's complete. The many special features are a mixed blessing—experienced users will need them, but beginners may be intimidated.

HomePak is one of the first single-disk interrelated packages offered for the 64. Although not really integrated, since the 64's memory allows only one program to reside in RAM and still leave room for user-entered data, each of the three main *HomePak* modules is still an independent self-sustaining component. Yet, when necessary, data can be transported from one module to another.

HomePak, in addition to its many other attributes, warrants consideration since it's not copy protected. That's noteworthy. Instead, the author and publisher ask users to support their trust by not distributing pirated copies. I applaud this spirit.

By offering three innovative, versatile programs, *HomePak* gains a competitive edge: an unbeatable combination at an irresistible price. **C**

The Music Shop

Computer: Commodore 64

Publisher: Broderbund
17 Paul Drive
San Rafael, CA 94903

Medium: Disk

Perhaps there's a Mozart or Bernstein, or maybe there's another Lionel Richie or Steve Goodman slumbering in you, waiting to surface. Or maybe you are just curious about what all those cryptic messages on sheet music really mean. If this sounds like you, *The Music Shop* will be music to your ears.

For the uninitiated, there's a 44-page tutorial designed to teach some basics. Those who have some musical background will go directly to the handy reference card.

The Music Shop uses pull-down menus which are accessed via the joystick, keyboard, or a combination of the two. The program doesn't teach musical notation nor does it turn the computer keyboard into a musical playtoy.

Once the program is booted, a demonstration of the 12 songs on *The Music Shop* program disk begins. Included for your listening pleasure are such classics as Tchaikovsky's "Nutcracker," J.S. Bach's "Jesu," Scott Joplin's "Maple Leaf Rag" and the traditional "America." Once you create or recreate your own music, you can assemble your own demonstration selection on a separate data disk.

Creation and recreation are the two major functions. You do this by copying sheet music note-for-note by moving the cursor to the tools window where the staff world is (notes, rests, clefs, measures) or by pressing the joystick button if you've picked a note you want to repeat. Making the empty staff look like those of your sheet music is a simple process.

Each time you select a note, the best bet is a combination system: use the joystick to position the cursor where the note should be, then use the keyboard to select the note.

The most difficult process is selecting the sound to use for each of the

*Just a little interest
in the musical world
will find hours of
release in The Music
Shop.*

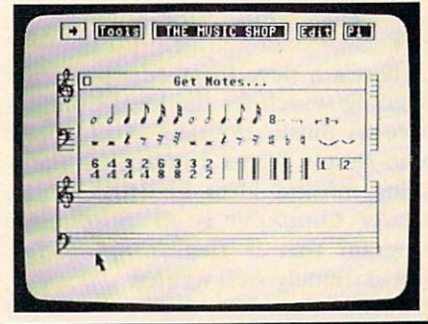

three available voices. It is disheartening to create your own work of art and play it back only to find it lacking the polish of tunes included on the disk.

It will likely be many months before your compositions take on a sound that will make listeners take notice when you debut them. Luckily, the program provides pre-sets that simulate instruments including an oboe, piano, organ, and violin. There are 16 pre-sets in all.

Those who aren't ready to create original music can still be inventive. Use the sound option to synchronize any two of the voices, add vibrato or other fine tuning adjustments until the piece is to your satisfaction.

Editing the composition isn't extremely difficult. Insert, cut out or copy from any existing composition. The program will also format a disk for saving your work and list the titles off the disk. To top it off, you certainly want to have a green background for the Irish jig you just composed. Easily done with *The Music Shop*. Want to share your composition with the world? The program will also print out the sheet music.

There is really very little to fault *The Music Shop*. The tutorial is well written and well organized, though a bit lacking in examples. No matter what the quantity and quality of your musical training, just a little interest in the musical world will find hours of release in *The Music Shop*. **C**

Master Composer

Computer: Commodore 64
Publisher: Access Software
 925 E. 900 South
 Salt Lake City, UT 84105
Medium: Disk

There's a new front runner in my ongoing search for the ideal Commodore 64 music program: For the user who simply wants a utility for translating musical ideas into SID music, *Master Composer* is an inexpensive program that is flexible, powerful, and extremely well written.

Master Composer is self-contained on a single disk, so it requires no program disk swapping. Enter, edit and arrange up to 127 measures of music, each containing up to 16 time steps. (This means, for example, that a measure in 4/4 time is divided into sixteenth-note intervals.) Several 127-measure segments link together from an easily-written BASIC program.

Master Composer has two basic operating modes: music entry (the input mode), and sound and sequence editing (the program mode). A "pseudo staff" notation is used in the input mode; the lines and spaces are identified with letters rather than by the usual treble and bass clef signs. There are four staff ranges available for notating pitches over a 6-1/2 octave range. The numbers one, two and three represent SID voices one to three, and the numbers four, five and six represent rests for each of the voices.

Notes are positioned in a measure with the cursor controls. Enter sharps, flats and naturals. These symbols are interpreted in the conventional way within the measure. For example, a sharp entered with a note at the beginning of a measure applies to that note throughout the measure.

When the music file is played, each note sounds according to the ADS part of the attack-decay-sustain-release cycle until a rest or another note is encountered. A rest initiates the release part of the cycle.

Play the currently displayed measure at any time and easily move from

For the user who wants a utility for translating musical ideas into SID music, Master Composer is an inexpensive program that is flexible, powerful, and extremely well written.



the current measure to any other measure. Erase a measure, change the key signature, copy a measure, or transpose the measure up or down an octave. A help screen reminds you of music entry commands. Saving and loading of music files is done from the music input screen. (Save music files on any preformatted disk.) Disk operations are easy and foolproof. *Master Composer* allows you to replace existing file names when you are adding to or editing a music score that was previously loaded.

In the program mode, you have access to the waveform and ADSR parameters for each of the three SID voices. Turn the filters on or off for each voice, adjust the cutoff frequency, change the tempo and SID volume, activate the sync and ring modulation modes, and turn off voice three when it's used to control the other voices. Each set of SID parameters applies to a single "block" of music.

The beginning and end of each, up to 64 blocks, can be specified by measure and position within that measure. A block can be as short as a single time step (a sixteenth note in 4/4 time) or as long as the entire composition. Easily move from one block to

another and play a block at any time either once or continuously in an "audition" mode that allows you to change parameter settings while the music is playing.

New blocks may be created or unused ones deleted. This allows you to alter the sound of notes anywhere in the middle of a composition without re-doing all the blocks after the change. You can also propagate settings in the current block to all subsequent blocks. From within the program mode, you can save and load voice settings on disk; there are several voice "pre-sets" available on the *Master Composer* program disk. (I find it just as easy and fast to create my own voices from scratch.) A help screen reminds you of program mode commands.

Master Composer provides considerable flexibility for arranging blocks into complete scores. Do this by specifying the order in which blocks are played; they may be repeated many times, skipped, or played in any order. Thus, repeated sections of music need to be entered only once. Repeated sections with different first and second endings are easily handled with the block concept. Information about how blocks are put together to form a complete piece is entered on a separate sequence page, which is called directly from the program mode.

An entire composition can be played from the program mode according to the information entered on the sequence page. The block, measure, note within the measure, and elapsed clock time are displayed along with a simplified staff that "writes" the notes as they are played. You can fine-tune the SID scale to match the pitch of other instruments.

An outstanding feature of *Master Composer* is its music files. Saved on disk, they contain all the information necessary to play without the *Master Composer* program itself. They contain all the notes in your composition, the SID parameters for each block, the block sequencing information for the composition, and a machine language program for playing the composition. This file can be loaded and played from within a BASIC program, or even in the immediate mode with just

Continued on page 120

JUST IMAGINE...

A gorilla in the city?! An octopus and bear dancing underwater?! Sound absurd?
Not with JUST IMAGINE!



This unique educational program from Commodore lets you design stories that may be as imaginative or as true to life as you desire. Gain valuable practice in important areas such as spelling and reading, word to image association, creative writing, simple word processing—all while your imagination runs wild!

JUST IMAGINE has 9 background scenes, 25 animated characters, and 48 stationary objects from which to choose. Enough possible combinations to please even the most creative minds! Select the ones you would like to include, then use the word processor to create a descriptive, entertaining story. It's just like directing your own mini-motion picture!

JUST IMAGINE flying a kite in the park . . . diving for sunken treasure . . . staging a shootout in the old west . . .

COMMODORE 
EDUCATIONAL SOFTWARE

Insta-Ledger

Computer: Commodore 64
Publisher: Microsci
 2158 Hathaway Street
 Santa Ana, CA 92705
Medium: Disk

When I first heard that this program was my old friend *Hot Accounts*, I had my doubts. I'd been using it to keep my books for the last two years and had had few problems. Marketed by Computer Educational Software at \$64.95, I thought it was a good program at a good price. But Microsci has successfully made a good program even better.

Insta-Ledger now has a "security key" (also known as a dongle) that protects your data from unauthorized access and discourages illegal copying. Users are allowed to make as many backup copies of the program as they need. By adding the key, they've eliminated the banging disk drive head that accompanied *Hot Accounts*'s protection scheme. They also did away with the \$20 charge for a backup disk. On top of that, the suggested list for *Insta-Ledger* is now \$44.95.

The only complaints I had about *Hot Accounts* were the size of the documentation (a three-ring binder) and the nonstandard printouts. Thankfully, both of these are addressed in *Insta-Ledger*. The new manual (easily held in one hand) contains the same well organized, completely illustrated instructions. Samples show exactly how data should look when printed on a dot matrix printer, whether printing graphs or reports. Sample screen displays show how things look when sent to a monitor.

Insta-Ledger has several features that make it especially nice for users inexperienced in bookkeeping. I don't think I've ever seen an accounting program that doesn't assume you already know everything there is to know about bookkeeping. This one doesn't. For instance, you are told how to create a chart of accounts and what it is used for. Two samples (one for a business, one for home) are provided.

In its original incarnation, I had no qualms about recommending Insta-Ledger to any small business person who doesn't quite need a double entry ledger system. Now it's even better.

Because each item in the main menu is thoroughly explained, it is hard to get lost. For each option, a general description, detailed instructions, sample responses, and screen or printed report samples are given.

Printouts from printers other than Commodore used to look a bit strange because the headers were supposed to be printed in expanded, boldface type. The print control codes sent to non-Commodore machines gave erratically-sized or spaced print. Alignment by decimal tabs was also thrown off. The new version has a "plain vanilla" printout; no fancy stuff. It looked great on both of my printers.

There are some features about the program that really make it stand out. If you are entering data and need to return to the main menu, typing three decimal points takes you there instantly.

Also, when you are entering data, the program locks out inappropriate responses. Dates consist of six numbers: month, day, year. *Insta-Ledger* checks to be sure they are valid dates (no February 31 allowed). Alphabetic characters will not be accepted for numeric values; they won't even appear on the screen. A year consists of four digits, period. It is almost impossible to fool this program.

In fact, when you complete your revenue or expense entry, *Insta-Ledger* checks to be sure you entered a valid account number from the chart of accounts. If not, it instructs you to

LEDGER INFORMATION SEARCH

SELECT: 1 SEARCH BY DAY OF EXPENSE
 2 EXPENSES OF ENTIRE MONTH
 3 LEDGER ACCOUNT NUMBER SEARCH
 4 AMOUNT SEARCH
 5 TYPE (CASH-CHECK-CARD-OTHER)
 6 SEARCH BY CHECK NUMBER

SELECT: A SINGLE FACTOR SEARCH
 B TWO FACTOR SEARCH
 C DISPLAY ALL EXPENSE RECORDS

SELECT BY NUMBER:

0 OPEN THE FIRST INSTA-LEDGER FILES
 1 * ADD NEW ACCOUNT NO. & DESCRIPTION
 2 * POST NEW EXPENDITURES TO LEDGER
 3 * DEPOSIT REVENUE TO THE ACCOUNTS
 4 RESEARCH INFORMATION & CREATE REPORTS
 5 MONTHLY INCOME STATEMENT AND BALANCES
 6 END OF PERIOD ACCOUNTING TRANSACTIONS
 7 JOURNAL ADJUSTMENTS - DELETIONS
 8 FILE MAINTENANCE/RECORD SORTING
 9 BACK-UP FILES AND END PROGRAM

LEDGER INFORMATION SEARCH

021005	■	120	COMPUTER EQUIP	302.40
022205	\$\$	510	EPSON RX-80 PRINT	
			OFFICE SUPPLIES	36.45
022305	\$\$	510	HOUC/PRINTER RIBBONS	
			OFFICE SUPPLIES	7.35
022305	\$\$	510	JAFFE/COPYING CHARGES	
			OFFICE SUPPLIES	43.50
022005	✓	550	JAFFE/SMALL HARDWARE	
			OFFICE	67.50
		CK# 245	RENT AND LIGHTS	
				776.01

PRESS ANY KEY TO CONTINUE

re-enter the data. And there are no cryptic error messages to decipher.

Check the available ledger space to be sure you have enough room for the data you anticipate. The memory is given as the number of records that can be added, rather than as the amount of memory available.

The program is almost bullet-proof. On only rare occasions have I made the program bomb-out to BASIC. And those occasions were generally due to

Continued on page 32

SMART-START™

MAKES PROGRAMMING FUN AND EASY FOR EVERYONE!

Sound, graphics and other advanced features are what make the Commodore 64 as popular as it is. But these features can also require a lot more programming know-how than many Commodore owners care to learn. That's why MUSE® developed SMART START™ to harness the power of the Commodore and put it conveniently at your finger-tips.

Here are just a few of the things you can do with SMART START™.

- You don't need to be familiar with the Commodore keyboard, SMART START™ lets you quickly select all functions from pull-down menus with cursor or joystick.
- No need to type long instructions to LOAD, RUN, SAVE and CATALOG programs, with SMART START™ you press a single key.
- Easily design colorful graphics and exciting sound effects. SMART START™ automatically generates the BASIC code for use in your own programs.
- Keep track of time with an on-screen digital clock and alarm.
- Always just a keystroke away ... works with any program you're running.
- Merge multiple programs into one.
- Easily print out screens and programs.

Get the most out of your Commodore 64 with a SMART START™ from MUSE®.

Suggested retail price \$39.95

For limited time includes second BASF Qualimetric disk FREE

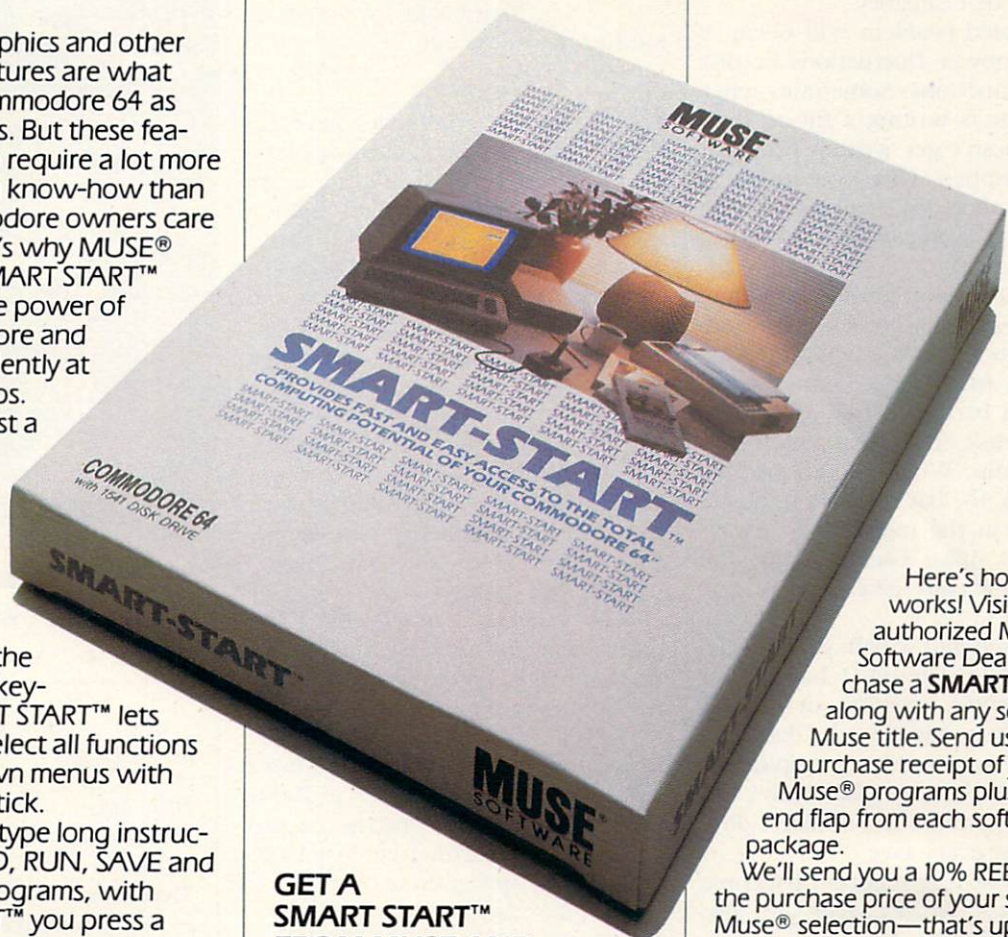

GET A SMART START™ FROM MUSE AND WE'LL GIVE YOU A HEAD START ON YOUR NEXT SOFTWARE PURCHASE!

GET UP TO AN \$8 REBATE DIRECTLY FROM MUSE®!

EXPECT THE EXCEPTIONAL...

**MUSE®
SOFTWARE**

347 N. Charles Street
Baltimore, MD 21201
(301) 659-7212

Commodore is a registered trademark of Commodore Business Machines.

Here's how it works! Visit your authorized Muse® Software Dealer. Purchase a SMART START™ along with any second Muse title. Send us the purchase receipt of your two Muse® programs plus a title end flap from each software package.

We'll send you a 10% REBATE on the purchase price of your second Muse® selection—that's up to \$8 back from Muse®. Rebate value will vary according to program and dealer's actual selling price.

MUSE® SOFTWARE REBATE OFFER

Yes, I want a 10% Rebate

Name _____

Address _____

City _____

State _____ Zip _____

Allow four to six weeks to receive your rebate directly from Muse®. Offer expires June 30, 1985. Offer void where prohibited by law.

an error on my part. For instance, if you delete an account number from the chart of accounts without creating a replacement category with the same number, you'll get a BASIC error message if any of your revenue or expenses use that category.

One related problem will occur, if you have power fluctuations or disk drive malfunctions. Sometimes when *Insta-ledger* is writing a file to disk, the file doesn't get written properly. This can happen when you are doing a sort or other disk maintenance. In most cases, this means the file doesn't get written at all.

This could be a terrible situation, but *Insta-Ledger* comes prepared. From the moment you begin creating data disks, *Insta-Ledger* expects you to create a backup. After formatting your data disk, it prompts you to format a backup. When you choose the quit option, the backup data option is listed first in the menu. It is always prudent to make backup copies of data. *Insta-Ledger* gives you no excuse not to.

With three and a half years of accounting data entered, I have never had to re-enter expenses or income once they were saved to the disk. I've had drive errors and made stupid mistakes, but the backup disk always had the latest information because I do a backup after every save.

Besides creating reports of income and expenses, *Insta-Ledger* will also graph your figures. You can compare categories of expenses to see where your money is going, or look at your income and see what enterprise generates the most bucks. These graphs can be sent to the screen or to a printer.

Despite my misgivings, *Insta-Ledger* turned out fine. All the best features have been kept, including the bell sound that accompanies disk swaps and input commands. Yes, the error buzzer is truly obnoxious, as it should be. The slight improvements have made it an even better value than before, and the drop in price is better yet.

In its original incarnation, I had no qualms about recommending it to any small business person who doesn't quite need a double entry ledger system. Now I'd recommend it even more highly. C

Fast Load

Computer: Commodore 64
Publisher: Epyx
 1043 Kiel Court
 Sunnyvale, CA 94089
Medium: Cartridge

A number of companies have created products to increase the speed of the Commodore 1541 disk drive. One device, a utility program, is said to speed the loading process by 300%. By why waste time loading a disk in order to load a second disk more rapidly? Another device involves hard-wiring the computer and disk drive, thereby voiding your warranty. Even then, this device may not work with certain commercial copy-protected software. But now there is *Fast Load* from Epyx. It is on cartridge so it can be left in the computer at all times—except, of course, when you're playing cartridge games.

Besides being a load utility, *Fast Load* provides a DOS wedge. You may list a disk directory without erasing the program currently in memory by typing "@" Load a disk by depressing the Commodore key while pressing RUN/STOP. Load a BASIC program by typing "/(name of program)." Load machine language files by typing "%(program name)."

You may also send commands to the disk drive by typing "@(command)" rather than the old, familiar "open (command) close" sequence. And when your drive flashes the red light to signal trouble, you may read the error channel easily.

Fast Load also contains copy programs—one for BAM copy, another for file copy and one to copy the entire disk.

Copying a disk is incredibly quick. Using the "Copy Entire Disk" routine, only three passes are needed to duplicate a disk on which 66 blocks are filled. The three passes added up to 2:05 minutes read time and 6:45 minutes write time. BAM copy of another program, 558 blocks long, took a similar amount of time and passes.

You may also format a disk from the *Fast Load* menu, a task which took one minute, 25 seconds to perform. Not bad. But does it load fast? C

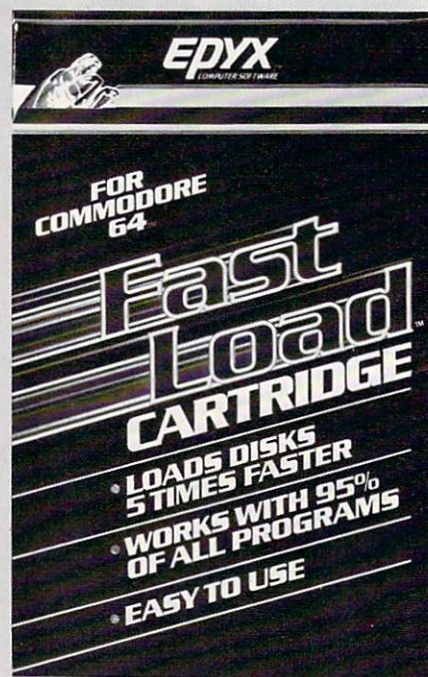

The following table represents loading times of some of my favorite software.

Disk	Normal	Fast Load
<i>Blue Max</i>	2:45	2:15
<i>Sky Travel Manager</i>	2:45	1:30
<i>Easy Script</i>	2:15	2:00
<i>F-15 Strike Eagle</i>	1:03	:57
<i>Unguard</i>	3:07	:45
	:50	:27

As you can see, the gain with many commercial disks may not be worthwhile, although others show significant time savings.

Sky Travel posted not only a good gain, but had an added bonus. Because of its complexity, this program must constantly access the disk as new routines are called. Speed of access and the writing of new screens was noticeably improved. Remember the name only for as long as it takes you to buy a copy. Forget the package blurbs promising five times faster loading. Think of it as a hard-wired DOS wedge and a fast and easy-to-use copy utility, then take the sometimes-fast disk loading as an added bonus. Thought of that way, *Fast Load* is definitely a worthwhile addition to your library. C

NEW LOW PRICES FROM THE WORLD'S LARGEST SPORTS SOFTWARE COMPANY!

Whether you're a coach, player, computer bug, statistician, dabbler, doer or just a real sports fan, PDS has a package for you...at our lowest prices ever! Check our line-up below, and then order your first PDS Sports Package.

FOOTBALL STATISTICS. A comprehensive computer software system. You compare teams in over 60 offensive and defensive situations and watch the matchups on the screen. Every team is given a power rating. PDS also provides "year-to-date" data diskettes for a nominal charge. 39.95

FOOTBALL HANDICAPPING. (Includes FOOTBALL STATISTICS Package). Forecasts the outcome of football games based on massive amounts of statistical data, morning lines and point spreads. 49.95

BASKETBALL STATISTICS. The most comprehensive basketball program ever written. "What-if" your way into every imaginable comparison and formulation. 39.95

BASKETBALL HANDICAPPING. (Includes BASKETBALL STATISTICS). Gives you an inside look into the outcome of games by mathematically equating statistics, lines and point spreads. 49.95

BASEBALL STATISTICS. See how opposing baseball teams stack up against each other. See summarizations. Performance stats on every team in the major leagues. 39.95

BASEBALL HANDICAPPING. (Includes BASEBALL STATISTICS) Makes you better-prepared to predict the winner of any game. At least, mathematically. 49.95

THOROUGHBRED HANDICAPPING. This "world class" program gives you an edge in predicting winners. A proven system...by PDS and many horseracing enthusiasts. 129.00

HARNESS RACE HANDICAPPING. The fast, easy way to find out what races and what horses should be looked at...all summarized in a "power rating" format. 129.00

QUARTER HORSE HANDICAPPING. the computer system actually "rates" the horses in each race of what is the fastest growing segment in the sport of kings. 129.00



TRAINER STATISTICS. Analyzes all local race-horse trainers and gives you a rating for each one. 39.95



JOCKEY STATISTICS. A short time with this software package will show you why the top 15 jockeys at local tracks win over 90% of all races. 39.95



HARNESS DRIVER STATISTICS. A complement to the HARNESS HORSE HANDICAPPING System, this package tells you all you need to know about the man (or woman) behind the horse. 39.95

PDS SPORTS™

P.O. BOX E / TORRANCE, CA 90507 / (213) 516-6688
Please send me the following PDS SOFTWARE PACKAGE:

_____ \$ _____
 _____ \$ _____
 _____ \$ _____
 Total

Add \$6.00 for postage and handling.
 Calif. residents add 6½% sales tax
 I have an APPLE () IBM () TRS-80 ()
 COMMODORE-64 ()
 DISKETTE () CASSETTE (); MODEL # _____
 () Check enclosed
 () Charge my credit card: A.E. (), VISA (),
 M.C. ()
 Card No. _____ Expires _____
 Signature _____

(As it appears on credit card)

OR CHARGE BY PHONE...CALL (800) 222-2601
 (In Calif: (213) 516-6688)

NAME _____
 ADDRESS _____ PHONE _____
 CITY _____ STATE _____ ZIP _____

Dealer Inquiries Invited

Fleet System 2

Computer: Commodore 64
Publisher: Professional Software
 51 Fremont Street
 Needham, MA 02194
Medium: Disk

Professional Software's *Fleet System 2* is more than simply a word processor/spelling checker package. It is also an educational tool—a detailed, step-by-step tutorial. The instructional secret is the logically organized user's guide, a literal teacher that starts by simply orienting you with your equipment, then breaks into chapters designed to build your skills.

But lest I commence by conveying a misconception, all you groaning computer veterans can just settle down. For I can assure you that *Fleet System 2*, composed of *Fleet Writer 3* and *Fleet Speller*, is potent enough to handle all of your writing.

The screen display consists of 22 lines of text area capped with an ever-present status line. These top two lines are a reserved space, where the computer will ask for information, give instructions, or highlight one of the five letters—X,F,I,S,N—allowing you to monitor which function is currently in use. The manual's author compares this string to the "pilot lights of an automobile dashboard." Taking the analogy one step further, let's give our *Fleet System 2* its road test.

Getting Comfortable

Before we actually take to the streets, a couple of adjustments must be made to insure a safe trip. First off, the *Fleet System* diskette is copy-protected so a duplicate cannot be made. If you are accident prone, or like the secure feeling of a back-up, you might want to order another copy as soon as you return your registration form. Details are outlined in the license agreement that comes enclosed.

Next, you must provide the program with your printer model and screen colors. This word processor will work, without modification, with 21 different printers. A checklist is prompted on-screen, and you choose your model. Then you decide which

Take it from someone who used to approach any typewritten project with a 3-1/4 inch paint brush and a gallon of white-out: Fleet System 2 is potent enough to handle all of your writing.

screen colors are most pleasing. When these configurations are complete, you're ready to go.

Gentlemen, Start Your Engines

To put this program through its paces, we might as well shift through the assortment of symbols that tops our screen.

Pushing into first lights up the "X," indicating that you are writing in the extra-text area, one of the two sections into which the available memory of the Commodore 64 is divided. When the "X" is extinguished, you've switched to its larger and more significant counterpart: the main-text area. It's here where you wrestle with the guts of your novel, letter, term paper or speech. This space can hold the working text in either 40-, 80- or 120-character lines. The latter two choices are useful when your manuscript calls for the insertion of charts or tables. But the 40-character selection remains my favorite, since it allows for copy to be viewed without horizontal scrolling. This is an asset when evaluating continuity and flow.

Later, the *Fleet System 2* side-steps the 64's display limitations. First, it allows you to preview your work in a much appreciated 80-character print-to-screen option, then permits you to print a hard copy in any width up to 132 characters.

The main-text area gives you 450 40-column screen lines (translating to about eight or nine pages of completed work). This will probably be enough to satisfy the majority of your needs. But even in the event that you

write like Cosell talks, there's no need to fret. When faced with space restrictions, *Fleet Writer 3* will recognize linked files as one, allowing for almost limitless document length. This "global" bridge can be crossed in the print mode, as well as in some edit functions.

But be careful. Personal experience has taught me not to fill any file to the brim when planning to merge. This only causes migraines when you try to make a last minute addition and the "no vacancy" sign blinks on. Remember to leave yourself some room to maneuver.

Now, back to the extra-text area. This cleverly designed subsidiary keeps about 140 40-character lines waiting in the pits, allowing you to perform operations on the sidelines without disturbing the main text. For example, the *Fleet Writer 3* has some reference items, such as a "help" file, added onto its disk. These, or any user-created directory, can be called upon and checked against when you are immersed in some other function.

Also, form letters, with gaps left for the insertion of variable information, can be created, since you have the ability to transfer copy from the extra- to the main-text area. And even if you just have a paragraph or long phrase that you use frequently, it can be stored and copied with just a couple of keystrokes.

Text Editing

The next gear, "F" on the status line, represents the function mode, which is used to access almost every aspect of the editing process. All the tailoring functions that you would expect to find in a professional-level product have been included.

You can delete letters, words or sentences. Blocks of text can be copied and moved around. Paragraphs can be split or married, bulks of copy totally eradicated, and words, phrases or pages can be inserted anywhere.

As a matter of fact, in this cornucopia of editing delights, I could find only two missing elements. One is the absence of deletion recall, a function which lets you bring back any copy you might have disposed of in fickle haste. But the program does try to avoid mistakes by asking for a confir-

SOFTWARE REVIEWS

mation of your command before trashing your text, so it's less of an omission than a technical preference.

But the number of extra options quickly outweighs this personal vexation. The depth of the editing process might be best exemplified by an operation called search and replace.

Let's say you're Elmer Fudd's secretary, and only after typing 20 pages of dictation, do you realize that "wascal wabbit" was a descriptive mispronunciation. All you have to do is tell the computer which word you would like to replace, state your new entry, and push a button. The *Fleet Writer* will do the rest, scanning the copy and correcting all errors before Elmer "wealizes what went wrong."

The third and fourth gears—"I" and "S"—are also an extension of the editing mode. The former is a continuous insert function, to be used in the event that you have a large amount of text to be squeezed into your manuscript, while the latter indicates that you are in the shift mode. Similar to a typewriter's shift lock, shift mode will print all capital letters, while keeping the other keys in their normal setting. This can be helpful when you are developing a piece that is entirely upper case and don't want to be bothered remembering to unlock the shift key.

And keeping with their easy-to-use image, Professional Software has included a handy cardboard reference card, as well as the disk-stored help file.

Text Formatting

The thoroughness in design that simplified the task of creation is mirrored by the available options for text formatting. Margins, headers (including page numbers), footers, centering and justification are all under your control, while italics, underlining, boldface, Spanish language characters and changeable letter width can be used at your discretion.

In essence, if you can do it on your typewriter, you can do it here. Even tabs are set in the traditional style, with the addition of a numeric tab, represented by the final letter on our status line. This mode allows for the formation of columns of numbers and even simple computerized calculations.

Not only can the Fleet Speller point out misspellings, it can also tabulate the number of sentences in your manuscript, the average number of words per sentence, or the number of times any word appears.

Printer output can be continuous or staggered. You keep control, stopping and starting the printer at will. But the best is yet to come.

Spell Checking

For me—and I don't believe I'm a unique breed—one of the most time-consuming chores in writing has always been the page flipping, back-and-forth dance to the dictionary. My nightmares are over. For *Fleet System 2* comes complete with built-in spell checking.

Using a dictionary of over 75,000 words (with the option of adding another 12,000), this program has the potential of cutting hours off my work load. Granted, as advanced word processors become more profuse, this function will no longer be considered so novel. But it is included with this package and is *powerful*. Not only can the *Fleet Speller* point out misspellings, it can also tabulate the number of sentences in your manuscript, the average number of words per sentence, or the number of times any word appears.

So take it from someone who used to approach any typewritten project with a 3-1/4 inch paint brush and a gallon of white-out. If you own a Commodore 64, and do a little writing, there is no reason why you shouldn't invest in a word processor. And when you're shopping around, look for the professional product that's not afraid to wait for a newcomer: *Fleet System 2*. It's a bargain that can compete with any state-of-the-art product. C

SOFTWARE

COMMODORE 64™

35 PROGRAMS (DISK)
or
25 PROGRAMS (TAPE) **\$12.95**

COMMODORE 16™

25 PROGRAMS (DISK)
or
20 PROGRAMS (TAPE) **\$14.95**

COMMODORE PLUS 4™

30 PROGRAMS (DISK)
or
25 PROGRAMS (TAPE) **\$15.95**

FOR ALL ORDERS
add \$2.00 shipping & handling
(foreign, except Canada-\$3.00)

selected public domain programs

**GAMES, UTILITIES,
BUSINESS, EDUCATION,
GRAPHICS, & MUSIC**
(DOCUMENTATION INCLUDED)

send check or money order to

MADA ENTERPRISES, INC.

**P.O. BOX 1382
BELLEVUE, NE. 68005**

FOR MORE INFORMATION, WRITE DIRECT
OR CIRCLE READER SERVICE NUMBER
COMMODORE 64, 16, and PLUS 4
are trademarks of Commodore Electronics Ltd

Circle Reader Service No. 22

COMPUTEREYES™

VIDEO IMAGES ON YOUR COMMODORE!

Finally - an inexpensive way to capture real-world images on your Commodore's Hi-Res display! **COMPUTEREYES™** is an innovative slow-scan device that connects between any standard video source (video tape recorder, video camera, videodisk, etc.) and the Commodore's User I/O Port. Under simple software control, a bitw image is acquired in less than five seconds. A unique multi-scan mode also provides realistic, grey-scale images. Hundreds of applications!

Package includes interface module, complete easy-to-use software support on disk or tape (specify), owner's manual, and one year warranty. **COMPUTEREYES™** is available from your dealer or direct from **DIGITAL VISION** for just \$129.95 plus \$4.00 S&H (USA).

Also available as a complete package including:
• **COMPUTEREYES™**
• Quality bitw video camera
• Connecting cable
for only \$349.95 plus \$9.00 S&H.

Demo disk available for only \$10.00 postpaid.

Mass. residents add 5% sales tax. Mastercard, Visa accepted. To order, or for more information, write or call:

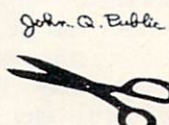

Screen dumps of actual **COMPUTEREYES™** images.

Also available for Apple II series.

DIGITAL VISION

DIGITAL VISION, INC.
14 Oak Street — Suite 2
Needham, MA 02192
(617) 444-9040

Circle Reader Service No. 8

The Write File

Computer: Commodore 64
Publisher: Tri Micro
 1010 N. Batavia
 Orange, CA 92667
Medium: Disk

The Write File is an integrated word processor and database manager which provides a great deal of flexibility and ease of use for minimal investment.

You may ask, "Who's Tri Micro?" Tri Micro supplied the integrated, built-in software for the Commodore Plus/4. And between the time I received the program and wrote this review, Tri Micro not only repackaged it, but upgraded it too. Wisely, they even revamped the documentation. Instead of weighing users down with reams of instructions, they have kept the manual to a respectable 33 pages. After the table of contents, three pages of quick reference cards explain the word processor, file manager and printer formatting. Unfortunately, though, they're bound with the manual so they can't be removed for later reference.

Next is a brief description of the program's capabilities as well as a list of needed hardware. For those totally unfamiliar with the 64, the manual conveniently provides the format command for data disk preparation.

There are some unusual numbers associated with *The Write File*. Only 99 lines can be accommodated per file, each composed of a maximum of 77 characters. Though unorthodox, the 77-character line (displayed 37 at a time) just takes some getting used to.

The length limitation is another matter. Though 99 lines are enough for most applications, there will be school or business tasks which require greater storage. However, long files may be saved in sections, then merged upon output.

Besides the basic word processing functions like insertion and deletion, *The Write File* offers a fine search-and-replace routine. Specified terms are highlighted in a sequential, user-controlled procedure which permits customized, one-word-at-a-time

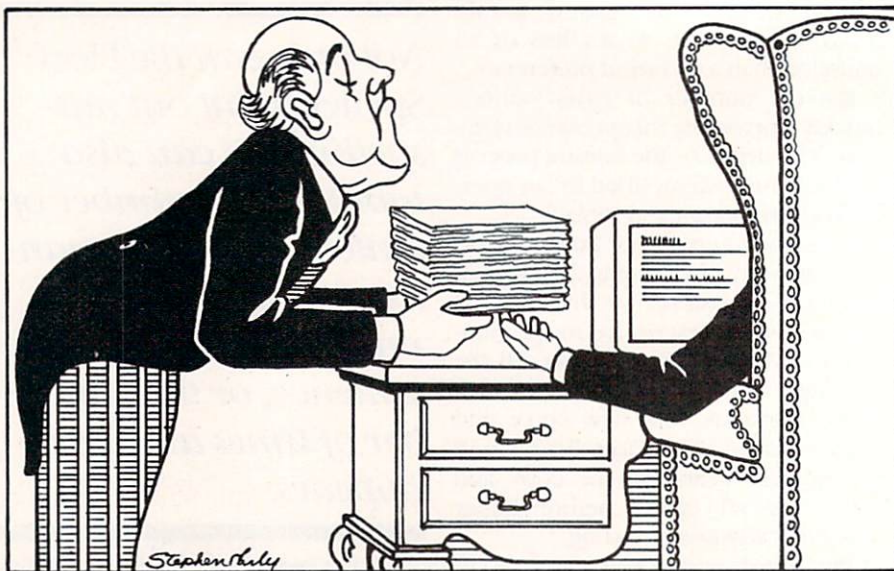

The Write File gives 64 users some of the sophistication previously the sole province of computers costing five times as much.

changes.

A critically important set of features includes the program's power to copy, insert and delete blocks of text. Anyone who puts their thoughts down on paper knows the importance of re-editing draft after draft until the final work is polished and smooth. This "debugging" process is much less frustrating and time consuming when you can merely whisk parts of the text from place to place. The reproduction of text is especially useful when instructions or captions are repeated throughout the work. Up to 15 lines of text can be handled at a time.

A really nice touch is the recall function which is the ability to bring back one line of accidentally erased text. This can be a lifesaver when the pressure's on and your fingers are all thumbs. (Sounds like an average day for me, actually.)

But let's back up a bit. One of the most important features in a word processor is cursor control. Besides the standard CRSR and RETURN keys, *The Write File* provides other means

of movement. F7 jets the cursor to the right of the page while F8 does likewise for the left. The CLR/HOME key sends the cursor the top of the file in its existing column. SHIFT CLR/HOME sends the cursor to the bottom of the file.

Finally, CTRL/left arrow sets tabs. A word to the uninitiated: *The Write File* automatically sets a tab at line 77. Except for this preordained setting, all tab locations are displayed on the status line at the bottom of the screen.

The other major portion of the word processor deals with printer output. Numerous ASCII-based commands can be inserted into the files to drive the printers. Features like bold-face, shadowprint, underline and enhanced mode are supported.

Page-formatting commands include the usual page length and margin widths as well as justify, wrap and pause (to change paper or daisy wheels). Other options include pagination, file linking, line spacing and adjustment to paper size. All these can be used in conjunction with font modification commands.

There is a blind spot here, however. These commands, text-embedded in a reverse video mode, work only on printer output. That means that there's no way to view formatted work before printing. Experience, though, can help compensate for this. Output can be performed with any Commodore or properly interfaced printer: daisywheel, thermal, dot matrix or otherwise.

Continued on page 124

A BRIGHT NEW STAR FOR A COMMODORE TO PRINT BY

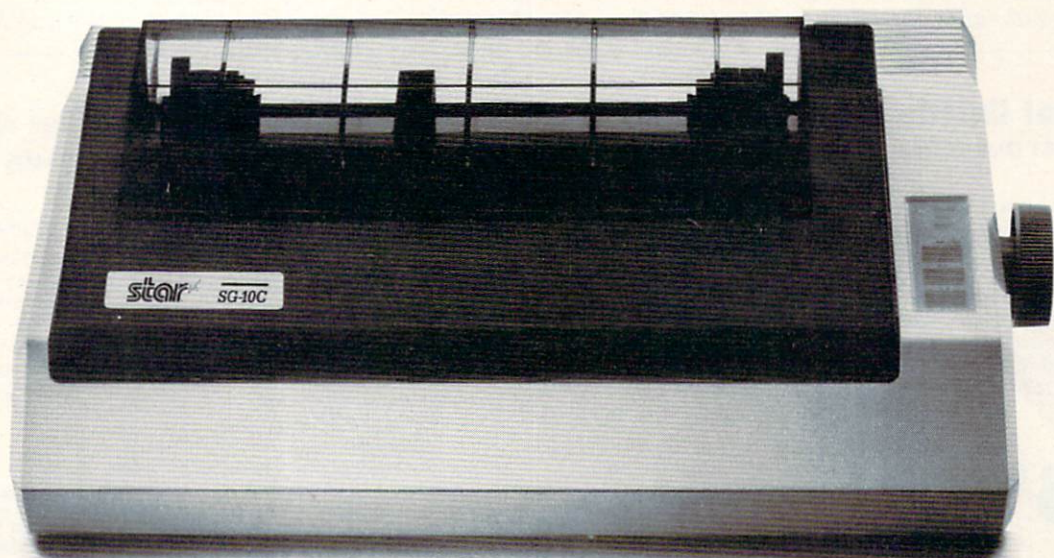

Now you can own a sophisticated, affordable printer that's made just for your C-64.™ Star's new SG-10C.™

Here's a dual-mode Star printer that delivers 120 cps draft/30 cps *near-letter-quality*. With an ample 2K memory capacity. Interface cable. And friction and tractor feed. All standard.

The SG-10C is Star's made-for-Commodore® printer. Made to be the easiest to interface. Made with more features (no add-ons necessary—just

plug into your computer and go to work). And made at a price that can't be beat. There just isn't a better mate for your Commodore.

You've got the computer. Now get everything out of it. Get the Commodore-dedicated SG-10C from Star. It's the best connection you'll ever make.

star 

THE POWER BEHIND THE PRINTED WORD®

200 Park Avenue, New York, NY 10166
Chicago, IL (312) 773-3717 • Boston, MA (617) 329-8560
Irvine, CA (714) 586-8850

Commodore and C-64 are trademarks of Commodore Business Machines, Inc. and/or Commodore Electronics Ltd.

D-Compiler \$59.95

The first D-Compiler to give you back your source code after your program has been compiled with *Blitz.

*Blitz is a trademark of Skyles Electric Works

1541 Super ROM \$39.95

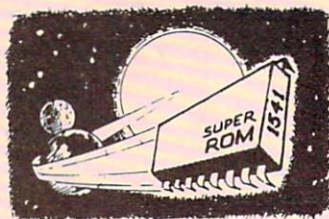

- Fast Save Load Verify
- Fast Scratch and Validate
- 10 Second Format with Verify
- No more Drive Head rattling during Format or Error Reading
- also Save with Replace is Improved
- Two times faster, Eight times faster when used with Turbo 64 which is included
- 1541 Super ROM is 100% Compatible
- Easily installed in Minutes

Survival Guide To The 1541 Disk Drive

This book is a must for anyone who might have any questions about the 1541 Disk Drive. Complete list of all Drive Commands. Includes troubleshooting, filehandling, Dos wedge commands and technical information along with complete detailed illustrations.

\$6⁹⁹

Computer Talk

Finally a complete how to book on telecomputing for the '64. Chapters include: How to get started with your modem and C-64 as well as how to access Dow Jones, The Source, Playnet, Compu Serve and your favorite Bulletin Board. Up and down loading are discussed as well as how to survive in the computer world.

\$6⁹⁹

The Original Book of Facts

UNLOCK THE MYSTERIES OF THE COMMODORE

- Simple Instructions
- Easy step-by-step examples
- Tricks you can do your first day
- Introduction to color, sound and much more
- Includes a routine to protest your own programs
- NO MATTER what your experience, the Original Book of Facts is for everyone!

\$6⁹⁹

The Advanced Book of Facts

EXPLORING YOUR COMMODORE

- How to use a machine language monitor
- Advanced protection for your own programs
- Full size reference charts
- How to design your own menus and more...

\$6⁹⁹

D-CODER

- Translates any machine language program into easy-to-read English descriptions with complete explanations of each command!
- Makes complete notations of all important memory locations accessed by the program! (SID, VIC, MOS, KERNAL, etc.)
- Gives you three ways of accessing programs:
 - 1) Will read and list programs from DISK
 - 2) Will read and list programs from MEMORY!
 - 3) Direct user input (from magazines, etc.)
- Can be used to easily break apart machine language programs for study and examination!
- Printer option for complete hard copy listings!

\$19⁹⁵

You no longer need to be an EGGHEAD to read Machine Language.



N-CODER

the machine language manipulator...

The perfect companion program to D-CODER!

Allows you to easily make changes in machine language programs... right on the disk!

- Rewrite ability allows code to be altered and then rewritten directly to the disk!
- Features sector-by-sector scrolling assembly language display of machine language programs!
- Notation of ASCII text equivalents for easy spotting of embedded text strings!
- Handy reference display of all assembly language commands and their ML numerical equivalents!
- Byte splitter for easy splitting of decimal addresses into low byte-high byte . mat!

\$19.95



Super Loader

Super Loader is a Kartridge that plugs into your expansion port, that allows the computer, on power up start the disk drive and load the first preselected program on the disk.

- Change colors
- Load wedge
- Works with more drive
- Takes up no memory
- Reset switch included



Only **\$29⁹⁵**

TOOL BOX

This Disk has over 100 routines, some of them are routines for protection, smooth scrolling, modem routines, and sound and color

routines. They can easily be incorporated into all of your programs. It is also fully documented.

\$19.95

Slik Load

\$29.95

Slik Load is a Kartridge for the C-64.
Slik Load is the most reliable, effective and thought out Kartridge of it's kind.

The options include:

- 5 times faster load
- Eliminates drive rattle when errors are encountered.
- Old and un-new Will restore a basic program

- Status key will give you information on device number, bytes free and status of the drive.
- Silk Load is also fully compatible with the 1541 Super Rom



\$19.95

DMS-Errors 20, 21, 22, 23, 27 & 29

Format Single Tracks
Read Disk Errors

Drive Mon-Disk Drive assembler/dis-assembler. For your 1541.

The Doc-Disk Doctor that reads code under errors.

Sync Maker-Place a sync mark on any track out to 41. Also used for protection.

Sync Reader-Check for Sync bits on any track out to 41.

Change Drive No.-Changes drive number (7-30).

Disk Logger-Finds starting track sector; start and end addresses.

Disk Match-Compare any two diskettes. Byte for byte.

New Wedge-Easier to use DOS wedge.

ID Check-Check ID's on any track.

Unscratch-Restore a scratched file.

View-BAM-Visual display of the free and used sectors on a diskette.

Read/Write Test-1541 performance test.

Repair a Track-Repair a track with checksum errors. Reads code under errors and restores track.

Fast Format-Format a disk in just 10 seconds (with verify!).

This is the only utility of its kind. It even has a 3 min. copy on it.

WAR GAMES AUTODIALER



- 1-Auto Dial will automatically dial a set of numbers you choose.
- 2-Review Numbers will review numbers that were answered by a computer.
- 3-Save Numbers will save numbers where a computer answered.
- 4-Hardcopy of Numbers will print out list of numbers where a computer answered.
- 5-LOAD Numbers will load in numbers to continue where it left off.
- 6-Continue will pick up dialing where it was interrupted.

\$29.95

KARTRIDGE KRACKER

NOW you can own this unique and powerful tool which will allow you to dump the contents of 8K and 16K cartridges onto disk! But what's really great is that you can also RUN the cartridges programs without plugging in the cartridge! the KRACKER gets YOU INSIDE the cartridge! Put all your favorites on disk and get rid of the clutter. This package provides your with the software and hardware needed to get started. Program on disk included. (Some cartridges require use of external RAM not included)



\$44.95

Directory Sorter

Have you ever tried to find a disk or program in your library and didn't know where to start looking? Well we have the answer here for you. This program will put your disk library on disk or give you a hard copy. You can have up to 900 File names, you can add save Purge file and cross reference anyway you want. This program is completely user friendly and easy to use.

\$19.95

TOP SECRET STUFF II

All C128 Compatible

- Split Screens (Horizontally)
- Smooth Scrolling
- Save Ram From Under Roms
- No Drive Rattle On Errors
- Triple Drive Head Speed
- Autoboot Maker
- Koala Screen DUMP
- Display GCR
- Fast Disk Eraser

- Protect Scheme For Your Disks
- Write Protect Disk
- Unwrite Protect Disk
- Mini D.O.S. Wedge
- Fast Diskmatcher
- Data Statement Maker
- Unnew
- 3 Minute Copy
- D.M.S.

If you have TSS#1, You'll Like This One! All on one disk **\$19.95**

Coupon-Clipper

For Commodore-64

- Optional Use of Printer
- Saves -- Stores -- Checks Shopping Coupons
- 30 Categories -- 2300 Records
- Self Deleting of Expired Coupons

\$19.95

This Coupon Clippers program will store up to 2300 different coupons and up to 99 of the same kind of coupons. You have up to twelve options on the main menu. Options: 1 - Add Coupons only; 2 - Pring Out; 3 - List of all Coupons; 4 - Expired coupons only; 5 - Free Coupons Only; 6 - Category Only; 7 - Change to Expired coupons only; 8 - To Make Up Shopping List; 9 - To Delete Used Coupons; P - Print Shopping List; T - To Terminate Program; L - To List Deleted Coupons; C - Change Viewing Time.

Bulletin Board

Set up and operate your own bulletin board with one or two disk drives. This one has all the features and you can customize it easily yourself.

- | | |
|-------------------------|--------------------------|
| 1-RUN MEGASOFT-BBS | 8-READ SYSOP MESSAGES |
| 2-CREATE MEGA FILES | 9-WRITE OPENING MESSAGE |
| 3-ADD TO SYSOP'S CORNER | 10-READ LOG |
| 4-NEW SYSOP'S CORNER | 11-CYCLE LOG |
| 5-READ MESSAGES | 12-READ DOWNLOAD FILE |
| 6-SCRATCH MESSAGE | 13-SCRATCH DOWNLOAD FILE |
| 7-CYCLE MESSAGES | 14-ADD TO OTHER SYSTEMS |
| | 15-CREATE OTHER SYSTEMS |

\$59.95

BBS

- Leveled Access
- Private Message Base
- Up to 300 Passwords
- Expert Mode
- Open Chalk Board for Highest Level Access

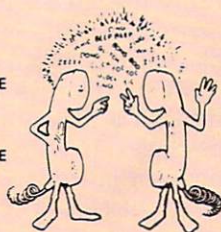

Enclose Cashiers Check, Money Order, or Personal Check. Allow 14 days for delivery. 2 to 7 days for phone orders. Canada orders must be in U.S. Dollars. VISA - MASTER CARD - C.O.D.

Programs for C-64 \$20.00 S & H on all orders



MegaSoft Limited

P.O. Box 1080, Battle Ground, Washington 98604

Phone (206) 687-5116 • BBS 687-5205 After Hours Computer-to-Computer

Software Submissions Invited.

Keyboarding and the Screen Editor

This month
we welcome
Commodore expert
Louis F. Sander as a
regular contributor.

It's safe to say that no hardware unit is more important than the keyboard, and that keyboarding know-how, even without touch typing, is the most basic computer skill. Without keyboard proficiency, working at the machine can be tediously slow, and more than a little frustrating. With it, even if you're not a typist, computing is much more rewarding. With this article and an hour or so of practice, you, or anyone, can become a keyboard expert.

Commodore keyboards are notable for their ruggedness and useful layout, and their good design sets Commodore apart from other brands. Commodore's excellent screen editor makes the keyboard even more useful. The screen editor is the built-in software which lets us use the keyboard to write things onto the screen, and to change them once they're there. But the keyboard and screen editor are so complex, with so many useful features, that few of us have really mastered their use. Since they really are easy to master, we're pleased to help you do it.

We'll explore our subject in depth, through a series of carefully chosen examples. If you type each one, and note our instructive comments, you'll be a black-belt Commodore keyboarder in no time. (Well, maybe not in *no* time—it takes an hour or so to do it right.) But your new-found knowledge will make you a faster keyboarder, and you'll easily regain that hour. Whether you're a skilled touch typist or a ten-thumb hunt-and-pecker, working our examples will make you a better computerist.

Our examples move quickly from



Every issue Lou will be addressing the needs of our beginners, to help them acquire basic computing skills and add to their enjoyment of their new equipment.

elementary matters to fine points, since power lies in the fine points, which are easy to learn and use. As you learn them, remember that practice makes perfect. The more you use each technique, the more natural it will become for you, and the more time you'll save at future keyboard sessions. Although we've created our examples on a 64, we've tested them on the VIC 20, Commodore 16 and Plus/4. Most of them will also be useful to PET and CBM owners.

The first step is to turn on your computer, with this article in front of you, and your user's manual standing by for reference. We'll assume that you have some familiarity with keyboarding on your machine. If you've typed in one or two short programs (and gotten them to run), you're ready to read further here. If you've not yet reached that point, start at the beginning of your user's manual, reading every page and doing every example.

It won't take you long to get some programs up and running.

Assuming you are qualified, let's start the examples. Each one is numbered, and each assumes that you've mastered the previous material. We recommend that you go through every one, to take advantage of our step-by-step learning program.

1. Observe the alphabetic keys—the ones lettered from A through Z. Each is labeled with a letter on the keytop, and two graphics symbols on the keyfront. The keytop symbol is printed whenever the key is pressed by itself. Press the "A" key now, and observe that an upper-case A is printed. (If you get a lower-case a, turn your computer off, then turn it on and start again.) Now press either SHIFT key, and while it is down, press the "A" key again. Notice that the right-hand keyfront character, a spade, appears on the screen. Press the Commodore logo key, and while it is down, press the "A" key again. This time the left-hand keyfront symbol, a small right-angled character, will appear. Take note of the SHIFT, Commodore logo and CTRL keys. They have different purposes, but they all work the same way—they must be fully depressed before another key is pressed, just like the shift key on a typewriter.

2. Now simultaneously press the SHIFT and the Commodore logo keys. Observe the changes in the three characters you typed in step one. The "A" becomes "a," the spade becomes an "A", and the graphic character remains unchanged. Press SHIFT and Commodore once more, and you'll return to the original character set. If you don't understand the two character sets, experiment with them and you'll get the idea pretty quickly. The two character sets differ only in the shifted and unshifted keys A to Z, plus three or four other characters (shifted @, shifted pound sign, and Commodore asterisk on all computers, plus shifted up-arrow on the VIC and 64).

3. Observe the numeric keys, labeled from one to nine. Notice that the keytops have two symbols: a number and a punctuation mark above it. The keyfronts are labeled with one or more colors or other words. Press the "6," then the shifted "6," noticing

that the SHIFT key causes the upper character on the keytop to be printed. (It's called an ampersand.) Observe that some other keys are labeled in this way, namely the colon, semicolon, comma, period, and slash. When there are, in addition to two labels on the keytop, other labels on the keyfront, the keyfront functions are enabled by pressing the key while the CTRL or Commodore keys are depressed.

Depending on your computer, you may have a few keys with only one label on the keytop, and one on the keyfront. These keys have the keytop function when unshifted, and the keyfront function when shifted. Examples of this are the programmable function keys on all computers but the Plus/4, and the up-arrow key on the VIC and 64.

4. Look carefully at the CLR HOME key, and notice that its labels work like those on the number key. Unshifted, the key has the lower function, HOME. Shifted, it has the upper one, CLR. The same is true for INST DEL and RUN STOP (and for the CRSR keys, on the VIC and 64). If you're aware of this principle, you're ahead of many experienced Commodore users. One key has a similar two-word keytop label, but it doesn't work in the manner described here. Can you find it?

5. By now you've found it: SHIFT LOCK, which works like the shift-lock keys on typewriters. Press it once, and every key becomes a shifted key. Press it again, and things return to normal. Notice that when it's activated, the key remains partially depressed, just like most other push on/push off switches. When your keyboard starts acting strangely, there's a good chance that SHIFT LOCK has been pressed by mistake.

6. Now that you're familiar with key labeling, experiment with your keys to see what they do under various conditions. If some keys give unusual results, such as printing a reverse-field graphics character, press RETURN and try them again. (You've inadvertently gotten into quote mode, which we'll explain later.)

At this point, you're reasonably familiar with the keyboard and what it does. From now on, each example will illustrate a specific characteristic

With this article and an hour or so of practice, you, or anyone, can become a keyboard expert.

of the Commodore screen editor. The screen editor, of course, is the always-running internal program that relates keyboard activity and the screen.

7. Type PRINT 7+7 <RETURN> and observe that your computer prints the sum, 14.

8. Type PRINT 8+8 <SHIFTED RETURN> and note that your computer ignores your command. When shifted, the RETURN key merely moves the cursor to the start of the next line, ignoring whatever you have typed. This is useful when you make a typing error and want to start again on a new line, without entering the erroneous material into the machine.

9. Type PRINT 9+9, then a handful of spaces or cursor rights. Press RETURN, and observe that the proper sum is printed. Conclusion: The cursor can be anywhere on a line, and when RETURN is pressed, the line will be entered into the computer. It's a simple fact, yet thousands aren't aware of it.

10. Move your cursor somewhere in the center of the next line, then type PRINT 10+10 <RETURN>. Observe that the computer accepts the line, even when it doesn't start at the leftmost position on the screen.

The following examples illustrate an important phenomenon that often vexes beginners—Commodore's so-called quote mode. When an odd number of quotation marks have been typed on the keyboard, the screen editor goes into a different mode, and certain keys (cursor keys, for example), instead of having their normal effect, print various reverse-field characters on the screen. Quote mode is usually entered by typing one quotation mark, but typing three, or five, or any other odd number will have the same effect. Quote mode is cancelled as soon as an additional quotation mark is typed (making an even number in total), or when RETURN or

SHIFTED RETURN is pressed. On the Commodore 16 and the Plus/4, it can also be cancelled by typing ESC O.

11. The purpose of quote mode is to allow BASIC's PRINT statement to be used for controlling the cursor, character colors, and other operations that are activated from the keyboard, but which do not print characters onto the screen. When the computer encounters a reverse field quote mode character in a PRINT statement, it executes the corresponding cursor movement or other action, rather than printing the quote mode character itself.

12. To illustrate quote mode, type one quotation mark (the shifted "2" key), then try pressing the cursor keys, CLR, HOME, and the CTRL number keys. Notice that each such key prints a reverse-field character, instead of performing its usual function. (On the VIC and 64, the function keys F1-F8 also do this.) Now simultaneously press the SHIFT and Commodore logo keys, observing that many of the reverse field characters change their on-screen appearance. Even though they look different, they will still perform the same function when included in a PRINT statement.

13. Type PRINT " <CLR> then five cursor downs, and notice the reverse-field characters. The CLR should have given you a heart, while the cursor downs should have given Q's. (If something else happened, you didn't get into quote mode.) Press RETURN and notice that the screen clears, with the READY prompt appearing five lines below its normal location. The PRINT statement read the heart and the Q's, interpreted them as CLR and cursor downs, then behaved as though those keys themselves had been pressed. Interesting, eh?

14. Type PRINT " <SHIFTED RETURN>, then several cursor downs. Notice that the cursor down key now moves the cursor down, instead of printing the Q's. That's because the shifted return took the editor out of quote mode. Also note that the screen didn't clear (because the return was shifted, as previously shown in step eight).

15. Type ABCDEFG, then put your cursor on the D. Press the INST key (shifted, of course, remembering step

Continued next page

four) and note that space is opened to the left of the D. Press the cursor down key, and note that the machine acts as though it's in quote mode. Do another cursor down, observing that quote mode has disappeared! The principle here is that inserted spaces behave as though quote mode is in effect. Typing a quotation mark into an inserted space does not put you into quote mode, *unless* the space it is typed into is the *only* inserted space, or the last one in a group of inserted spaces. If you type a quotation mark there, the editor will remain in quote mode until you exit it in one of the usual ways. (See example ten.)

16. This step applies to all computers except the VIC 20. If you understand character codes, you can use quote mode to improve your keyboarding, since CHR\$(1) through CHR\$(29) or CHR\$(31) can be entered directly from the keyboard. Get into quote mode and press CTRL A, which should produce a reverse field A. The other letter keys, B through Z, will behave identically. When a PRINT statement encounters the CTRL A character, it will print a CHR\$(1). CTRL B will print a CHR\$(2), and so on through CHR\$(26), printed from CTRL Z. The other such codes, not all available on the C16 and Plus/4, are:

CHR\$(27) CTRL colon
 CHR\$(28) CTRL pound sign
 CHR\$(29) CTRL semicolon
 CHR\$(30) CTRL up arrow
 CHR\$(31) CTRL left arrow

These codes are especially useful in working with printers, where CHR\$(1) through CHR\$(31) are often used to control special features. CHR\$(27), called ESC or ESCAPE by many printers, is the most common example. Inside your computer, many of these CHR\$ codes are used to move the cursor, change colors, and so on.

Sharp-eyed readers will see that the quote mode representation of RVS ON, or CHR\$(18), normally gotten by pressing CTRL and the "9" key, is a reverse field R. Since R is the eighteenth letter of the alphabet, a CTRL R will produce a CHR\$(18), which also appears in quote mode as a reverse field R. So a RVS ON can be produced either way. Once I learned this fact, I began using CTRL R exclusively, since that combination is much easier to

The screen editor is the built-in software which lets us use the keyboard to write things onto the screen, and to change them once they're there.

type with one hand than the standard CTRL 9.

17. Now let's enter some BASIC lines. Type 123REM (no embedded spaces), then press RETURN. List the line and observe that the computer has automatically inserted a space after the line number. This feature makes your listings easy to read, and it's the only time the computer adds anything to your input. Move the cursor to the center of a blank line, then enter 124REM. List line 124 and see that the leading spaces have been stripped.

18. Enter these lines: 0REM, 63999REM, -10REM and 64000REM. Note that the valid range of BASIC line numbers is from 0-63999. Attempting anything outside that range causes a syntax error. Enter the line 100.5 REM, then list it and see what happens. If you attempt to execute such a line, you'll get a syntax error. Now delete line 63999 by typing 63999 [RETURN]. List your program to see that the line is really gone. Repeat the process for lines 0 and 100.

19. Enter 19 PRINT "HELLO." List it, then put your cursor on the "H," and change the H to J. Press RETURN, then list the line again, noticing that HELLO has indeed been changed to JELLO. This illustrates the most important principle of the screen editor: To change a line, you just type the changes on the screen, then press RETURN. As in examples nine and ten, it doesn't matter where your cursor is on the line when RETURN is pressed, and it doesn't matter whether your line starts at the right margin. Whenever you press RETURN, everything on the cursor's current logical line is

entered into the computer. Unfortunately, many people are confused about this simple point, and they waste lots of time and keystrokes while editing BASIC lines.

20. Since the screen editor accepts anything on the logical line that the cursor is on when RETURN is pressed, it's easy to duplicate lines. Type 20 REM DUPLICATE LINE <RETURN>. Then put your cursor on the "0" in the line number, press the "1" key, then press RETURN. When you list your program, you'll see lines 20 and 21. This feature can be used to enter identical lines, or lines that are almost identical. In the latter case, you enter the first line, then use the cursor to change its line number and to make the other necessary changes. When you're finished, press RETURN, and the second line will be entered into memory. If you have additional similar lines, you can repeat the process.

21. Type 21REM, followed by 90 or more other characters. When you are finished, your cursor will be two or more lines below the line with the number. Move your cursor up to the line with the number, then press RETURN. A Plus/4 or Commodore 16 will give an error here, and the computer will not accept the line. If you have a Commodore 64 or VIC, list the line and observe that the computer has cut it off to 80 spaces (88 for the VIC), plus the computer-inserted space after the line number. That's the maximum number of spaces the screen editor will permit in a program line.

The whole point here is that there's a maximum line length the screen editor can handle—80 characters for the 64, and 88 characters for the other Commodore machines. It's interesting to know that BASIC can handle lines up to 251 characters in length. You'll sometimes see such lines in special or tricky programs, but they're never created by typing them onto the screen.

22. Type in another line, longer than your computer's line length limit, this time pressing RETURN when your cursor is at the end of what you've typed. You'll get an error message, and when you try to list the line, you'll see that it hasn't been entered. When the cursor passes the eightieth or eighty-eighth character,

COMPUTER WIZARD

the computer thinks that it's on a "new" line.

A valid line of text, composed of up to 80 (or 88) characters, and printed on up to four screen lines, is called a *logical line*. A logical line can cover one or more physical screen lines, up to the maximum length discussed above. A RETURN or SHIFTED RETURN starts a new logical line, which, at this point, is one physical line in length. When typing moves the cursor to the rightmost screen position of this physical line, the stage is set for lengthening the logical line. The lengthening takes place as soon as the spacebar or any printing key is pressed, wrapping the cursor around to the start of the next physical line.

The screen editor keeps careful track of physical and logical lines, even when they are scrolled up the screen. You can see this on a VIC or 64 if you list part of a program which contains both short and long logical lines. Move the cursor to the bottom of the screen, then observe what happens as you repeatedly press the cur-

sor down key. When a short logical line (occupying one physical line) is forced off the screen, the screen scrolls upward by one physical line. But when a single cursor down forces a multi-line logical line off the screen, the screen scrolls several lines, until the entire logical line has been forced off.

23. Everyone knows that "?" can be used as an abbreviation for PRINT, and many of us know the abbreviations for the other BASIC keywords. Type 23:?:?:? . . . repeating the "?:?" combination a total of 35 times. Press RETURN, then list line 23. Surprise! The computer has expanded the abbreviations, and the length of the listed line now exceeds the maximum length of a logical line. That's perfectly OK, since the concept of a logical line only applies when the screen editor is used to enter or edit material on the screen.

24. Using the listing you just made, edit line 23 by changing one of the first few PRINTs to an END. Move your cursor to the beginning of the

line—not usually important, but important here. Then press RETURN. A Plus/4 or Commodore 16 will give you an error. If you have a Commodore 64, or VIC, list the line and observe that it's been truncated, or cut off, to the maximum length of one logical line.

Examples 23 and 24 show that the screen editor can't handle anything more than the maximum logical line. It doesn't care whether key words are abbreviated, so long as you don't type or edit a line of more than 80 (or 88) characters. The older machines accept overlength lines and truncate them, while the newer ones reject them and give an error message.

Well, readers, you've just experimented with all the important features of Commodore's keyboard and screen editor. If you've meticulously followed our examples, you have a good understanding of Commodore keyboarding. In the future, we'll use that knowledge in a very interesting way—creating some graphic displays. C

YOU CAN DO MATH!

A math tutorial for students and adults who fear math (math anxiety). Step-by-step approach to:
Ratios

Designed and written by educators in a "plain English" approach. A unique product for a unique problem — overcoming math anxiety for improved career opportunities. Disk \$49.95

Decimals

Fractions

Percents

Algebra

 **MICROTECHNIC SOLUTIONS**

P.O. BOX 2940, NEW HAVEN, CONN. 06515

Dealer Availability

Call (203) 389-8383

Commodore 64*

*Commodore 64 registered trademark of Commodore Business Machines Inc.

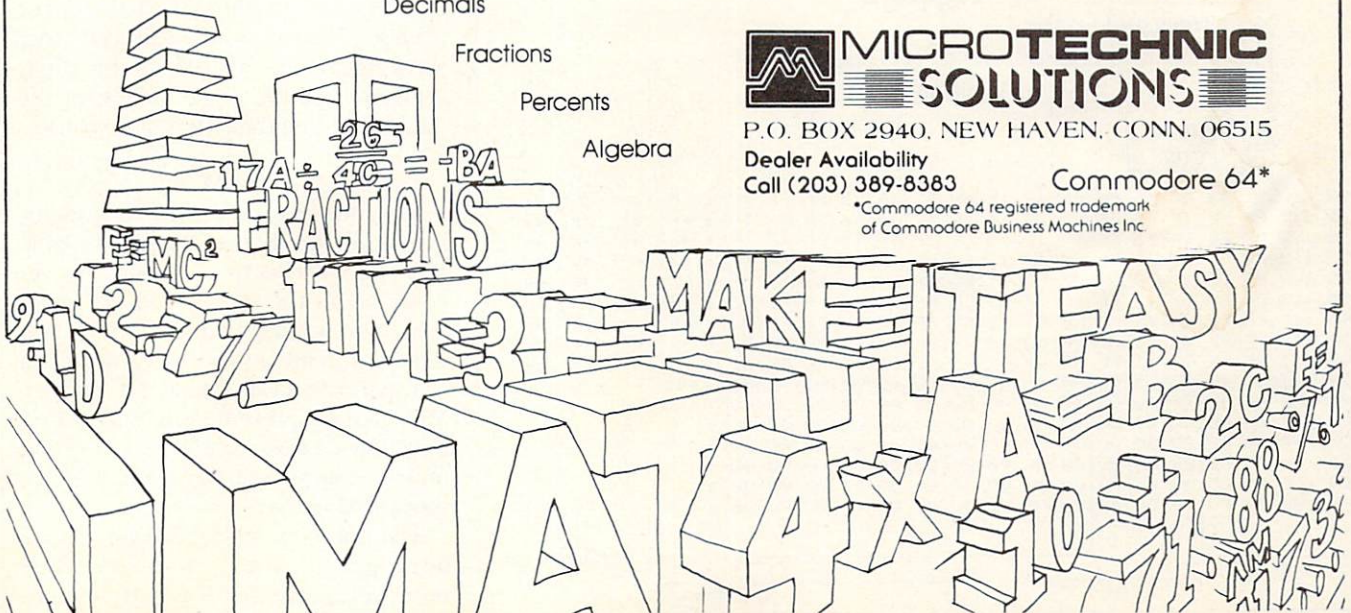

Display T&S

For Commodore 64,
VIC 20 & PET

In what form does the disk hold information? How can I look at it and change it? Just what goes in behind that closed door? If you have a 1540, a 1541, or a 2031 disk drive, this article will answer many of your questions and give you an insight into the working of your disk system.

Your disk saves information magnetically on tracks and sectors. The process is similar to an audio recording, except information is not recorded in one continuous track. The tracks on the disk are concentric rings.

The rings are numbered from the outside in. The outside ring is track one. The inside track is track 35. Each track is made up of a number of blocks (also called sectors). Each sector holds 256 bytes of information.

Because the outside tracks are longer, they have more sectors than the shorter inside tracks. Figure 1 shows how many sectors are on each track.

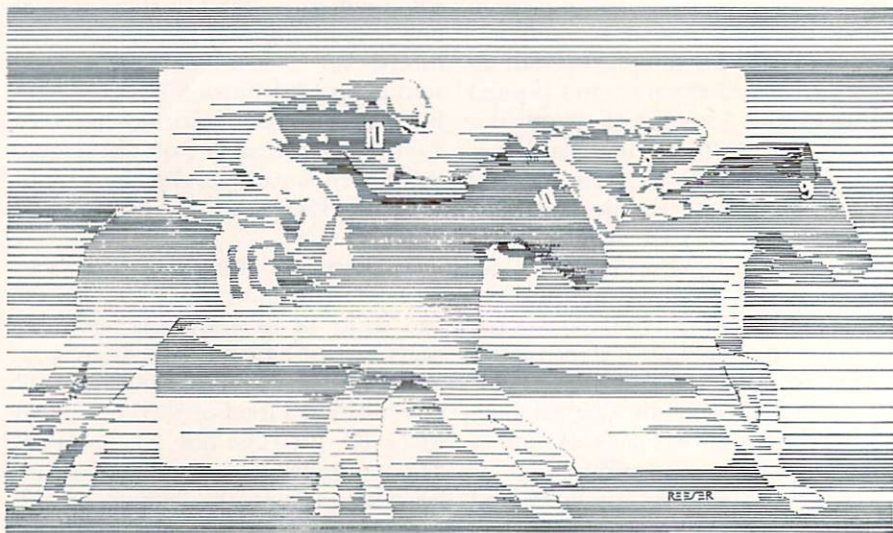

Figure 1. Number of Sectors on Each Track

Tracks	Sectors
1 to 17	21
18 to 24	19
25 to 30	18
31 to 35	17

These total 683 sectors, each capable of holding 256 bytes of information. The maximum possible disk capacity, therefore, is 683 times 256, or 174,848 (174K) bytes.

But we can't use the entire disk capacity to store data. We need a place to hold the names and addresses of the programs, like the index of a book. This index, or directory, is on track 18 along with the Block Available Map (BAM). As you can see from Figure 1, track 18 has 19 sectors. If we subtract that 19 from the 683 total sectors, we have 664 sectors or blocks free. This is the number you see after you HEADER or NEW a disk: 664 BLOCKS FREE.

Viewing a Sector

You will need a program in order to view the data in the sectors. One such program is on the disk that came with your drive. The program is called DISPLAY T&S—Display Track and Sector. It can print the display to screen or printer. The program will not only show the data, but off to the right, will give you the ASCII values for the data, decoding the letters and words.

BAM

The first sector on track 18 is sector zero, and holds the Block Available Map (BAM). This one sector keeps account of all the blocks that are available to be written to (blocks free), and which ones are allocated. Figure 2 is a printout of BAM (track 18 sector). Your screen presentation will differ, four bytes across or eight, depending on the program you have, and will not show all 256 bytes.

The numbers we are looking at are hexadecimal (hex) numbers. Hex numbers are a base-16 system. In con-

Figure 2

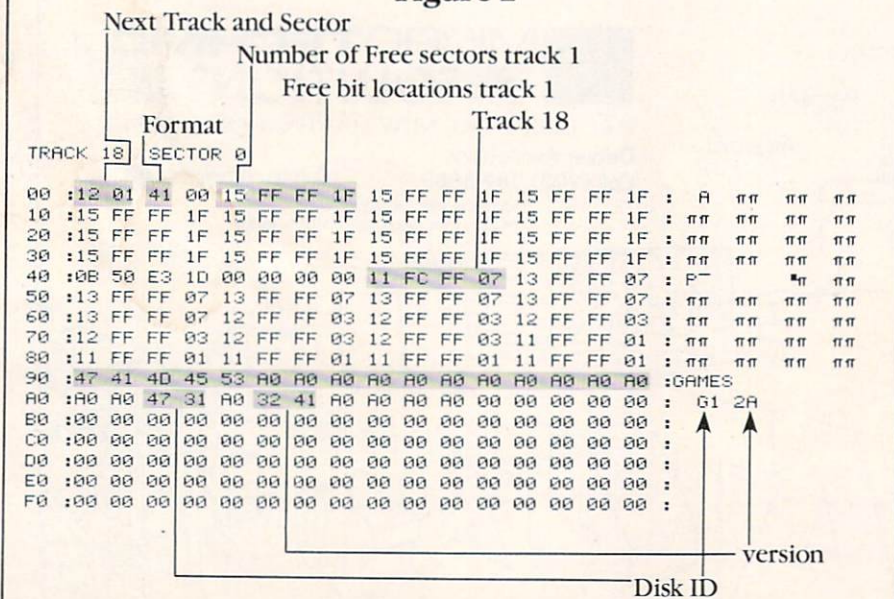

PROGRAMMERS' TIPS

and version number—so that it will create a five-letter word, such as a name. By experimenting with BASIC token numbers, you can also achieve words larger than five letters. The remainder of track 18, sector zero is unused.

Directory

Figure 3 shows track 18, sector one. This is the beginning of the directory, which uses the remainder of track 18. Thirty-two bytes are used to hold the information for each file on the disk. Again the first two bytes are for guiding the disk to the next track and sector. In this case, they are 00 FF. This tells the disk drive that there will be no need to go to the next track and sector—the information here will finish off what is needed.

If there were more than eight programs on this disk, the number 12 04 would be in the first two bytes. This tells the disk drive to go to track 18, sector four for additional information. It may seem unusual that it would not go on to track 18, sector two, the next sector down the track. But for reasons of read time, data assimilation and speed, the drive writes in a predetermined set of sectors, approximately on the opposite side of the track from the last sector written.

Byte two (the third byte) is number 82. This holds the type of file. Among other things, this number decides what gets written on the screen when you ask for a directory (LOAD "\$",8). As for this number 82, it will write the letters PRG after the name "KENO."

The next two bytes, 11 00, is the

The first two numbers in any sector are the address of the next sector. This tells the disk drive where to go for continued information when it is finished reading this sector.

address where the beginning of the program KENO is stored: track 17, sector zero. When you ask for a program to be loaded, the disk comes here to get the address of the program.

The next 16 bytes are for the program name. In this case, only the first four bytes were used. The remaining bytes stay as A0, or decimal 160. Decimal 160, by the way, is a shifted space.

The next three bytes are for relative files. The first two are for pointers to the side-sector chain. The following byte would hold the length of the record parameter.

The last two bytes in this section of 32 bytes are for the number of blocks that the program occupies. In this case, the first byte holds hex 18 (decimal 24) and the second byte holds 00. The number in the second byte is multiplied by 256 and added to the first byte, and displayed on the screen

when the directory is called. In this case, this first directory name will be shown as: 24 "KENO" PRG.

The next 32 bytes are a repeat for the next program. In this case, the first two bytes are not used. This is only for the first two bytes on a sector and is used as a guide to the next sector.

The third byte is 00, which indicates that this file has been scratched. The next program saved will overwrite this location. If you scratch a file, you can go to this location and insert the proper number, in this case an 82, and the program can be recovered. However, if you use this technique, BAM doesn't know about it and would show the program blocks as free, which means they still could be written over. This can be remedied by either changing the BAM bit mapping, or loading the program, saving it to another disk, and scratching this one again. Or do a validate, which would also correct the BAM.

File

Figure 4 is an example of a stored program file. In this case, it is the program that was scratched in Figure 3. Even though the program was scratched, the directory still shows the disk address (13 00, or track 19, sector zero).

Again, the first two bytes are links to the next sector—in this case to track 19, sector ten. If the final sector has been reached, the number of the track will be a 00 to indicate the last sector, and the number in the second, or sector location, will indicate the number of valid bytes of this 256. The next two bytes are the load address, which will tell the computer where to begin storing the program in the computer when it is loading.

Because this is a program file rather than, say, a sequential file, it has line links and line numbers, and the program looks just as it will look in the computer, if viewed with a monitor.

There are a number of things you can learn using Display Track and Sector. You can see what programs are hidden (scratched) on your disk, recover scratched files, see how a sequential file looks when saved, and find the load address for programs. Use Display T&S a few times. You will find it is a handy utility. C

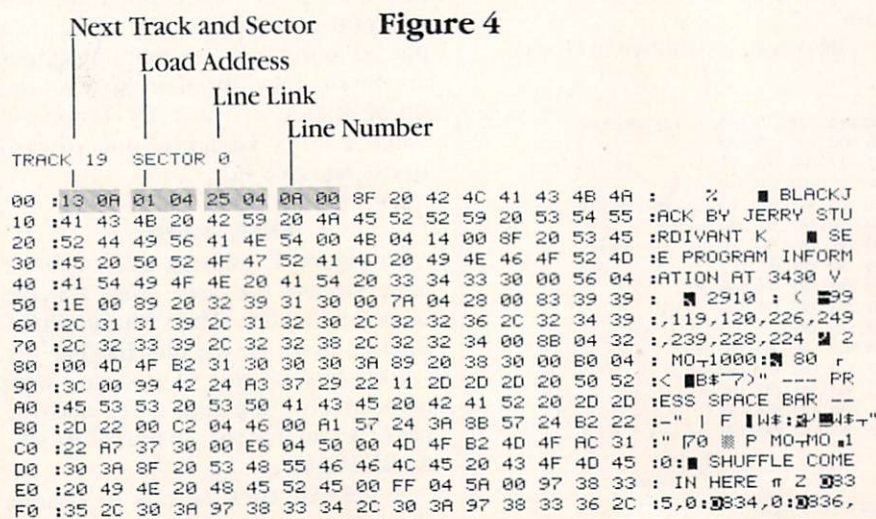

Memory Finder for the Commodore 64 and VIC 20

There are a number of reasons for poking into program lines. There are some things you just can't enter in the conventional way. For example, if you poke an 18 into the space after a REM, the statements following the REM will be reversed on the screen when you list the program. Poke a one into the space after a REM, and the statements will be expanded when listed on a printer.

You also go into a program to change line numbers so they can't be removed. Ever tried to enter a line number larger than 63999? Try it. You get a syntax error. This also happens if you try to *remove* a large line number. So, for instance, I like to make the last line number of my programs a big one (say, 64000) with my name on it, thereby making it difficult for someone to remove my name from the program.

If you use a machine language monitor to change a program for these—or any other—reasons, you have to load it, then search the program for the line number. This means you have to first convert all the numbers from hexadecimal to decimal.

Memory Finder is a program that will list your program line numbers and the memory locations of each first byte. In this way, you will know the memory location of the line you want to poke. You can use Memory Finder in immediate mode, or enter it in your program as a line. It can also spread out on a couple of lines.

In immediate mode, it looks like this:

```
S = 2049:FOR I = 1 TO 9E9:
M = PEEK(S) + PEEK(S + 1) * 256:
L = PEEK(M + 2) + PEEK(M + 3)
* 256:PRINTL,M + 4:S = M:NEXT
```

As the first two lines of a program, use this:

```
1 S = 2049:FOR I = 1 TO 9E9:
```

Memory Finder lists your program line numbers and the memory locations of each first byte so you can make changes more easily.

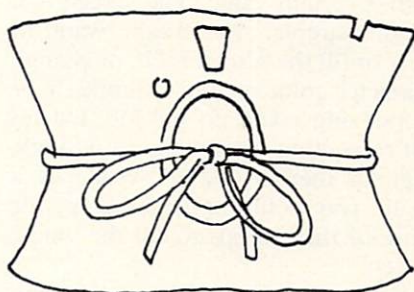

```
M = PEEK(S) + PEEK(S + 1)
* 256
```

```
2 L = PEEK(M + 2) + PEEK(M + 3)
* 256:PRINTL,M + 4:S = M:
NEXT
```

If you do put it in one line, or in immediate mode, you will have to abbreviate the BASIC words to make it fit. Abbreviate the FOR by entering "F" and a shifted "O." For PEEK, enter a "P" and a shifted "E." For PRINT, use a question mark, and for NEXT, use "N" and shifted "E." Thus it will fit on two lines.

Here is how Memory Finder works. A program line has two bytes that don't show when you list the line. These are line links to the next line link. The next two bytes are for the line number, then come the program bytes themselves. These are followed by a single byte called a line delimiter, which doesn't show on the screen, but marks the end of the line (this byte is always a zero).

The "S" or start is the memory location for the first byte in your program (the first line link byte). For unexpanded VIC, make S equal 4097, for 3K expansion, make S equal 1025. And for 8K expansion and over, make S equal 4609.

The FOR/NEXT loop is to put you into a permanent loop (the "E" is a

number when used in this mode; in this case 9E9 is nine billion). The M, or memory, is the memory location that the two line-link bytes are pointing to. The L is the line number following those bytes.

When you hit [RETURN], or if you make it a program line and run it, it will skip the first line in the program and begin printing the program lines and memory locations. To slow the scrolling, hold down your CTRL key and watch as the line numbers of the program scroll by. When you see the line number you want, hit the STOP key. The number next to the line number is the memory location of the first byte of the selected program line. List the program line and count bytes, starting with the memory number.

Remember, when you count bytes in a program line, there is no space, or byte, between the line number bytes and the first program byte, even though there is a space when you list it on the screen. And remember that BASIC words are only one byte long.

When running Memory Finder, if the line numbers start getting weird, or you get ?ILLEGAL QUANTITY ERROR, then you are peeking past the end of the program. If it keeps running, hit the STOP key.

Try it. With a program in your computer, enter your last line the way you want it to read. Make your last line number something like 10000 or 60000. Run the Memory Finder. When you see line number 10000, or whatever number you picked, scroll by, then hit the STOP key. The number next to the line number is one larger than the memory location of the second line-number byte.

In immediate mode, poke a 255 into the second byte of the line-number bytes. For example, if the numbers on the screen were line number and memory location:

```
10000 2005
```

Then you would subtract one from the memory location and enter

```
POKE 2004,255
```

This will change the one byte of your line number. Now list your program. Your last line number is now "unremovable." If you wish to reverse the process, poke in the number 249. This will change the number to something that can be removed. C

PROMAL 1.1 Features

COMPILED LANGUAGE

- Structured language with indentation as syntax element
- Fast, 1-pass recursive compiler
- Simplified syntax requirements
- No line numbers, no terminators
- Long variable names (31 characters)
- Global, Local & Argument variables
- Byte, Word, Integer & Real data types
- Decimal or Hexadecimal number types
- Functions with passed arguments
- Predefined DATA of any type
- Procedures with passed arguments
- Built-in I/O library
- Arrays, strings, pointers
- Control Statements: IF, IF-ELSE, WHILE, FOR, CHOOSE, REPEAT-UNTIL, BREAK, NEXT, INCLUDE, ESCAPE, REFUGE
- Bit-operators, shifts, casts
- Compiler I/O from/to disk or memory
- Variables at defined location
- Simple Machine Language interface
- Recursion fully supported
- Compilation errors trapped for Editor

EXECUTIVE

- Command oriented, with line editing
- Memory resident at all times
- Allows multiple user programs in memory at once
- Function key definitions
- Program abort and pause
- 22 Resident system commands, 8 user-defined resident commands, no limit on disk commands
- Prior command recall facility
- I/O Re-direction to disk or printer or from disk or keyboard
- File system management commands
- Memory map, set and display commands
- Batch job file support

EDITOR

- Full-screen, cursor driven
- Function key controlled
- Line insert, delete, search
- String search and replace
- Block copy, move, delete & write to/read from file
- Auto indent, undent support
- Edit-after-error facility

LIBRARY

- 45 Machine-language commands, memory resident at all times
- Call by name with arguments
- String handling (9 routines)
- Re-directable standard input and output files (STDIN, STDOUT)
- Formatted I/O (including Reals)
- Decimal & Hexadecimal I/O
- Block fill, Block move
- Block read, Block write
- Cursor control & line editing
- Data type conversion
- Random number function
- Real function support (in PROMAL): ABS, ATAN, COS, EXP, LOG, LOG10, POWER, SIN, SQRT, TAN



PROGRAMMERS' TIPS

BY JOHN J. KARCHER

Self-Modifying Machine Language Programming

Every so often in your programs you want to fill a section of memory with a certain value. The screen is a good example. You might want to clear or fill the screen itself, or change character color memory. Simple X or Y indexing could do the job, but no self-respecting screen fits in a single page of memory (256 bytes). As a result, you would have to use two or more of these loops to fill the whole screen.

An excellent example of a screen that takes more than 256 bytes is a bit-mapped graphics screen. If you have worked with bit-mapped graphics, you know how long it takes to clear the screen, let alone do anything. This is because a bit-mapped screen takes up 8K, which equals *thirty-two* pages! You would have to use 32 loops to clear it.

Now, there must be a way to

shorten this. If we could change the high byte of the address (INC or DEC) once every loop, we could make an X loop inside a Y loop (or the other way around). A single loop-in-a-loop routine would do it. So let's try. Let's say the screen is at 8192 to 16191 (\$2000-\$3F3F). Use the procedure in Listing 1.

If we get rid of X and Y, our program becomes ultra-flexible. Just by changing a few bytes in a few addresses, we can get the program to fill any number of bytes with any value. But why index at all? Why not just INC the low byte, too? What good is Y doing? Why not just compare the high byte to its destination? Let's get rid of X and Y, as shown in Listing 2, and see what happens.

Now run it. Remember how long it took BASIC to do it? But speed isn't the only advantage. By changing \$4001, you can fill the screen with anything. By changing \$4003, \$4005 and \$4006, you can move the area to be filled. And with just a little extra programming, you can get it to stop at any byte, not just at the right page.

This technique can be expanded indefinitely to do many jobs. I found it to be very helpful in many sticky situations. I hope it will be useful

to you. **G**

Listing 1.

```
4000 LDA #000 ;A = 0
4002 LDY #20 ;Y = 20
4004 LDX #000 ;X = 0
4006 STA $2000,X ;Store A in 2000 + X
4009 INX ;X = X + 1
400A BNE $4006 ;If X hasn't wrapped around, back to 0, then
;GOTO 4006
400C INC $4008 ;Add 1 to the value in 4008
400F DEY ;Y = Y - 1
4010 BNE $4004 ;If Y does not equal 0, then GOTO 4004
4012 BRK ;Stop the program
```

Listing 2.

```
4000 LDA #$FF ;A = FF
4002 LDX #40 ;X = 40
4004 STA $2000 ;Store A in 2000
4007 INC $4005 ;Add 1 to the value in 4005
400A BNE $4004 ;If 4005 hasn't wrapped around back to 0, then
;GOTO 4004
400C INC $4006 ;Add 1 to the value in 4006
400F CPX $4006 ;Compare X with the value in 4006
4012 BNE $4004 ;If they aren't the same, then GOTO 4004
4014 BRK ;Stop the program
```

It doesn't take much to make your programs run up to 20 times faster.

If you've been writing programs for your Commodore 64, Apple IIe or Apple IIc in BASIC you can take a giant step forward in speed of execution and in programming productivity for just \$49.95.

You can get program performance that you only thought possible from machine language programs. While still using a powerful, understandable high-level language. A language that's similar to Pascal, but much easier to learn and use.

You can create programs with our advanced, full-screen editor—much like you would on a word processor, and it even locates your compilation errors.

And when you compile your programs, you have a fast one-pass compiler, a recursive descent compiler that can compile a 100-line source program in 10 seconds or less.

PROMAL™ also gives you an elegant operating system "Executive," which includes powerful file, program and memory management commands and even I/O redirection.

You get all of that with PROMAL—improved programming productivity, faster compile and run time and power that you may never have thought possible.

PROMAL—for the beginning or advanced programmer.

Whether you are just beginning to write or are an experienced programmer, you can be more productive with PROMAL (PROgrammer's Micro Application Language). It's easier to learn than Pascal, C or Forth. It provides you with a full range of powerful structured statements like IF-ELSE, WHILE, REPEAT, FOR and CHOOSE. And, because indentation is part of the language's syntax, it helps you write programs neatly and logically. There are no line numbers to worry about, and since comments don't take up memory space, you can document your programs completely.

COMMODORE 64 BENCHMARK

(Sieve of Eratosthenes)

	PROMAL	BASIC	COMAL	FORTH	PASCAL
Execution Time (secs.)	30	630	490	51	55
Object Code Size (bytes)	128	255	329	181	415
Program Load Time (secs.)	3.2	3.8	6.3	11.2	23.5
Compile Time (secs.)	8.5	—	—	3.9	108

PROMAL—a language especially for small systems.

Unlike languages developed for larger systems and squeezed into small systems environments, PROMAL was conceived and developed specifically for the small system. With PROMAL there's finally a language created for the environment in which you work.

Speed up your programs and step up your programming productivity.

You get all of that speed and productivity—with the PROMAL PM-200 "End-User" system (220 pages of

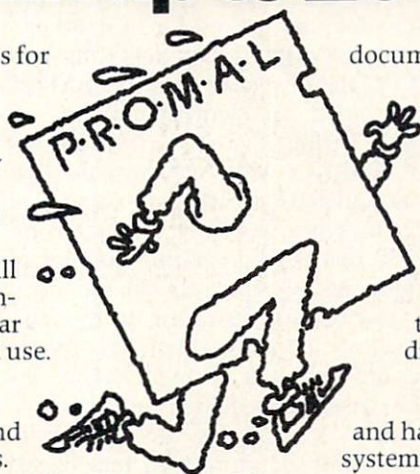

\$49.95 to be exact.

documentation and PROMAL system diskette including sample programs) for just \$49.95. There's a 15-day, no-risk moneyback guarantee. And the entire \$49.95 may be credited against later purchase of the "Developer's Version."

The "Developer's Version"—all the components of the "End User" system plus the "run time" object module generation capability, additional documentation and an unlimited right to sell or distribute PROMAL applications—is only \$99.95.

Or—for only \$10.00 plus \$2.50 postage and handling you can get the PM-100 demo system. It includes a 32-page manual and all the

capabilities of the PM-200 except the ability to print or save files to disk. It's a very inexpensive way to explore the wonders of PROMAL.

Our Guarantee: Try PROMAL for 15 days. If you are not completely satisfied, return it to us undamaged and we'll refund your money. No questions asked. Dealer inquiries invited.

For quicker response on credit card orders, call Toll Free:

1-800-762-7874

In NC: 919-787-7703.



Systems Management Associates
3700 Computer Drive, Dept. CMP
Raleigh, North Carolina 27609

Order Form

Please send me my copy of PROMAL

My system is (check one): Commodore 64 Apple IIe Apple IIc

PROMAL Package Desired (check one):

- PM-200 (for systems listed above) \$49.95 plus \$5.00 for shipping and handling at a total cost of \$54.95. Satisfaction Guaranteed.
- PM-300 Developer's Version \$99.95 plus \$5.00 for shipping and handling for a total cost of \$104.95. Satisfaction Guaranteed.
- PM-100 demo diskette \$10.00 for the diskette plus \$2.50 for postage and handling for a total cost of \$12.50. (Non-refundable.)
- My check is enclosed. Please charge my purchase to my Visa Mastercard

Card Number _____

Expiration Date _____

Signature _____

Name _____

Address _____

City, State, Zip _____

North Carolina Residents add 4-1/2% sales tax.
Foreign orders add \$15.00 additional shipping and handling.

XDOS

(User Extendable Disk Operating System)

XDOS is a simple, yet powerful, disk operating system for the VIC 20 and Commodore 64. Its commands are defined by the user as BASIC programs on the disk. XDOS supports the argument passing to the BASIC programs as well as a special LIST feature.

XDOS Commands

XDOS commands are entered as follows:

```
← COMMAND ARG1 ARG2
  ARG3 ... ARG10
```

The commands are flagged by the XDOS escape character (left arrow), and consist of a program name followed by optional arguments (up to ten) separated by spaces. Commands must be given in direct mode, neither preceded nor followed by other BASIC statements. XDOS loads the program COMMAND, starts it running and passes it ARG1 through ARG10 (if they exist) via the array ARG\$(or AR\$), one argument to an element (ARG\$(1)=ARG1, ARG\$(2)=ARG2).

For example, the normal disk command to rename a file is shown in Figure 1. The equivalent XDOS command is shown in Figure 2, where there is a program called RENAME on the disk defined as in Figure 3. You can easily see how a COPY program would be defined in the same manner. Additionally, a multiple file DELETE is shown in Figure 4. Note that since XDOS commands are program names, you can use disk wild-card specifications, so the DELETE could have also been as shown in Figure 5. Wild cards could be in the file names to be deleted as was in the command name.

A more complicated example is a TYPE command, shown in Figure 6, that takes multiple file arguments (up to ten) and types them on the screen. If there is more than one file, it also precedes each file by its name.

In the case of the COPY command, file names are looked for in fixed elements of ARG\$. For DELETE and TYPE, the programs loop over ARG\$ until either an element contains an empty string ("") or ten arguments are read. An APPEND program that concatenated an arbitrary group of files together would be another command that used a variable number of arguments. Commands do not need to have arguments at all. In the simplest case, preceding the name of any file on your disk with the XDOS escape character will load and run it.

XDOS commands are written in BASIC and therefore load into BASIC memory, replacing whatever is already there. Therefore, XDOS programs cannot operate on programs in memory. That is to say, you cannot write SAVE as an XDOS command, and you must save programs in memory that you want to keep before invoking XDOS commands.

The value of ARG\$(0) inside a command is the name of the program given on the command line, which is usually not too useful. However, it can be used in special programs that configure themselves based on what name they are saved under.

XDOS Directory

XDOS treats commands starting with \$ as directory requests. For example ← \$F* would load a directory listing with all file names starting with "F."

XDOS automatically does a LIST, instead of running the program, when \$ is used. Note that the directory is

loaded into memory, destroying whatever was there, unlike the disk wedge program included with the disk drive test/demo floppy. This feature was not developed further in order to encourage users to write their own specialized directory programs in BASIC, using the argument-passing features of XDOS to give wild-card specifications of which files to list.

Since all the commands reside on the disk, the optimal way to use XDOS is with two disk drives. All the commands would be on one drive and operate on files on the other drive, so that all your commands do not have to be on every floppy disk. To do this, you may need to change what drive XDOS loads from. Read about customizing the system below.

XDOS Internals

XDOS loads into the area of memory set aside as the cassette tape buffer, so no BASIC memory is used, and the program works with all memory configurations. The escape character is tested for during tokenization, so XDOS commands do not work inside BASIC programs, nor does XDOS affect the speed of a running BASIC program.

The current tokenization link is saved and jumped through when XDOS does not see the escape character, so that cartridges like Commodore's *Super Expander* cartridge, which extend BASIC, will still work.

When invoked, XDOS calls on the NEW routine to clear out memory. It does a JSR to SETMSG in the Kernal jump table to turn off control mes-

Figure 1.

```
OPEN15,8,15,"R0:NEWFILE=OLDFILE":CLOSE15
```

Figure 2.

```
←RENAME OLDFILE NEWFILE
```

Figure 3.

```
10 REM XDOS:RENAME
20 OPEN15,8,15,"R0:"+ARG$(2)+"=0:"+ARG$(1)
30 CLOSE15
```

Figure 4.

```
←DELETE FILE1 FILE2 ... FILEN
10 REM XDOS:DELETE
20 OPEN15,8,15
30 FORI=1TO10
40 IFARG$(I)=""GOTO70
50 PRINT#15,"S0:"+ARG$(I)
60 NEXT
70 CLOSE15:END
```

PROGRAMMERS' TIPS

sages, so that you do not see "Loading COMMAND. . . ." Once a program is loaded, the appropriate pointers are reset. Next, XDOS sets up the array ARG\$ (a string array of the default size) in memory, with its elements pointing back to the arguments in the BASIC input buffer (not string storage). Finally, the BASIC program starts executing without clearing memory again, in order to preserve ARG\$.

Since some programs use the space in the BASIC input buffer, you may find that the argument array has some spurious values in it. If this is the case, you will need to add the line in Figure 7 to the beginning of your program. Although this appears to do nothing to the array (appending a null string to each element), it actually forces BASIC to copy the strings from the input buffer to normal string storage. You need to copy only as many arguments as you use. Programs that read the

disk-error channel with INPUT#15, will have to do this, and possibly others.

Creating XDOS

The BASIC program in Listing 1 is a loader for XDOS. It should be entered and saved with the name XDOS.LDR (or anything but XDOS). When run, it will load XDOS from hexadecimal strings, and save a machine language

version of the routine on your disk under the name XDOS. Be sure you set the variable M on the first line for the machine you are using (20 for the VIC 20, 64 for the Commodore 64). The loader should warn you if you have made an error entering the hexadecimal strings. Once the loader has saved XDOS on your disk, you will need to power down and up again to reset all

Continued on page 120

Figure 5.

```
<DEL* FILE1 FILE2 ... FILEN
```

Figure 6.

```
<TYPE FILE1 FILE2 ... FILEN
```

```
10 REM XDOS:TYPE
20 FORI=1TO10
30 IFARS(I)="GOTO100
40 OPEN1,8,2,ARS(I)
50 IFARS(2)<>"THENPRINTARS(I):PRINT
60 IFST<>0THENPRINT"ERROR":GOTO90
70 GET#1,AS:IF64ANDSTGOT090
80 PRINTAS;:GOTO70
90 CLOSE1:PRINT:NEXT
100 CLOSE1:END
```

Listing 2. Machine Code

```
033C AD 05 03 85 FD A9 03 8D
0344 05 03 AD 04 03 85 FC A9
034C 51 8D 04 03 60 AD 00 02
0354 C9 5F F0 03 6C FC 00 A2
035C 01 E8 BD 00 02 C9 21 80
0364 F8 CA 86 FB 20 44 *6 A9
036C 00 20 90 FF A9 0E A2 08
0374 A0 00 20 BA FF A5 FB A2
```

```
037C 01 A0 02 20 BD FF A9 00
0384 A6 2B A4 2C 86 5F 84 60
038C 20 D5 FF 90 04 AA 4C 37
0394 *4 86 2D 84 2E 86 2F 84
039C 30 86 31 84 32 A9 00 A0
03A4 27 91 31 88 10 FB A0 06
03AC B9 F8 03 91 31 88 10 F8
03B4 A2 00 A0 08 E8 8A 91 31
```

```
03BC C8 A9 02 91 31 88 CA E8
03C4 BD 00 02 C9 21 80 F8 48
03CC 8A 38 F1 31 88 91 31 C8
03D4 C8 C8 C8 68 D0 DE A9 28
03DC 18 65 31 90 02 E6 32 85
03E4 31 20 8E *6 20 33 *5 AD
03EC 01 02 C9 24 D0 03 4C C3
03F4 *6 4C AE *7 41 D2 28 00
```

```
03FC 01 00 0B
```

(For VIC-20 * = C,
for Commodore 64 * = A.)

Figure 7.

```
10 FORI=1TO10:ARG$(I)=ARG$(I)+" ":NEXT
```

Figure 8.

```
<ECHO ARG1 ARG2 ... ARGN
10 REM XDOS: ECHO
20 FORI=1TO10:PRINTARG$(I);" ":NEXT
30 PRINT
```

Figure 9.

```
$FC - $FD LOCATION WHERE XDOS SAVES THE TOKENIZATION LIST.
$0356 95 THE XDOS ESCAPE CHARACTER (LEFT ARROW).
$0371 14 THE LOGICAL FILE NUMBER WHEN LOADING.
$0373 8 THE DEVICE XDOS LOADS COMMANDS FROM.
$0375 0 THE SECONDARY ADDRESS USED WHEN LOADING.
$03F8 AR THE NAME OF THE ARGUMENT ARRAY (TWO BYTES).
```

Listing 1. BASIC Loader

```
10 M=64:PRINT"LOADING FOR VIC20/64";
M'CGPE
20 M$="C":IF M=64 THEN M$="A"FIKD
30 FOR Q=150 TO 230 STEP 10:C=0'FMME
40 READ ADD$,MEM$,CSUM'BOHE
50 H$=ADD$:GOSUB 140:ADD=D'DPUG
60 H$=LEFT$(MEM$,2):IF H$=""GOTO
110'FQYI
70 IF LEFT$(MEM$,1)="*"THEN
H$=M$+RIGHT$(H$,1):R=1'IVTN
80 MEM$=MID$(MEM$,3)'CMYI
90 GOSUB 140:POKE ADD,D
:IF R=0 THEN C=C+D'HPQM
100 ADD=ADD+1:R=0:GOTO 60'ENGA
110 IF CSUM<>C THEN PRINT"ERROR IN
LINE";Q:END'GIGF
120 NEXT:PRINT"SAVING XDOS ..."CBYC
130 POKE 43,58:POKE 44,3:POKE 45,0
:POKE 46,4:SAVE"XDOS",8,1:NEW'GBNI
```

```
140 D=0:FOR I=1 TO LEN(H$)
:J=ASC(MID$(H$,I,1))-48'JXMJ
145 D=16*D+J+(J>9)*7:NEXT:RETURN'IMOL
150 DATA 33C,AD050385FDA9038D0503AD04
0385FCA9518D040360AD0002,2122'BHSM
160 DATA 354,C95FF0036CFC00A201E8BD00
02C921B0F8CA86FB2044*6A9,2999'BHMO
170 DATA 36C,002090FFA90EA208A00020BA
FFA5FBA201A00220BDFFA900,2803'BHKP
180 DATA 384,A62BA42C865F846020D5FF90
04AA4C37*4862D842E862F84,2493'BHIP
190 DATA 39C,3086318432A900A027913188
10FBA006B9F80391318810F8,2574'BHPQ
200 DATA 3B4,A200A008E88A9131C8A90291
3188CAE8BD0002C921B0F848,2950'BHUI
210 DATA 3CC,8A38F131889131C8C8C8C868
D0DEA9281865319002E63285,3090'BHGJ
220 DATA 3E4,31208E*62033*5AD0102C924
D0034CC3*64CAE*741D22800,1766'BHRK
230 DATA 3FC,01000B,12'BNTC
```

WHAT IS THIS GIRL DOING?

THE GIRL IS
 TH AX PAS GG3 ER2 LL PAS IH SS
 29 15 04 34 52 45 04 12 55
 FEEDING
 PAS FF IY PA3 002 IH NG PAS BB1
 04 40 19 02 33 12 44 04 28
 BREAD TO
 RR1 EH EH PA1 001 PAS TT2 UW2
 14 07 07 00 21 04 13 31
 A DUCK
 PAS EY PAS 002 AA KK2 PAS
 04 20 04 33 24 41 04



You can now have your computer speak to you... with the inevitable "Kilobaud Monster." This remarkable breakthrough in engineering is now being offered to the general public by Computel, and is made possible at a fraction of the cost you'd expect to pay anywhere else. You will also learn how computers speak, what speech synthesis is, and the basics behind phonemics. It's a great educational tool for the individual and for the institution alike!

The Kilobaud Monster is a revolutionary item for the hobbyist, because now you can have many new resources available for experimentation. No longer is this field of science limited to the lab, and no longer is its cost limited to governmental research projects. You can make your computer speak with little effort, a lot easier than you think!

The quality of speech pronunciation is excellent. Anything imaginable may be spoken, from scientific thru slang words—we include detailed instructions showing you exactly how to do this. You can now have all the satisfaction of doing this yourself, at a fraction of the cost, and having something really useful to show for your efforts!

*Devant
si je Puis*

KILOBAUD MONSTER?

ONLY \$9.95
regular price *

Introductory package includes everything you need to get started!

* SAVE—Computel members only \$ 7.95.



YOUR COMPUTER WILL TELL YOU! DON'T THEY ALL NOW "SPEAK" . . .

- Able to work with any computer!
- Complete instructions included!
- User-programmable vocabulary of virtually unlimited size!
- Program it to say anything you want!
- Guaranteed to hold your interest and delight for hours!

The Kilobaud Monster is the basis of a series of projects that can make your computer talk, and is necessary for later projects. The Kilobaud Monster will set you up with everything you need to know in order to attach it to your computer and enable it to speak words. All additional information is included with this beginner's package. The built-in editor in the Wordmaker enables you to easily "fine tune" every word you create to make it sound exactly as you wish. Or you can set up a "word bank" with the Message Talker that includes all the phrases and statements that you'll ever need! The Artificial Intelligence accessory will permit your computer to produce totally random sentences, following all the rules of correct grammar within a pre-defined vocabulary-set, all day long!

If you're new to the computer field, or if you're an old-time "hacker," you'll want to subscribe to our publication "Computel," which covers everything that YOU want to see! Encompassing the subjects of Computers, Electronics, and Telecommunications, this publication gives you a "new meaning" of the free enterprise system and the monopoly of existing organizations. You'll need to become part of this international hobbyist phenomenon really soon. SAVE \$2.00 on EACH ITEM you buy if you subscribe to Computel now! And this is IN ADDITION to the total package price for the Complete KILBAUD MONSTER Collection—you'll SAVE OVER \$18. Dealer and educational institution inquiries invited. Circle our Reader Service Number for additional information.

You may order these products from us by sending a check, money order, postage or cash in U.S. negotiable funds only, to the address indicated below. Or you may charge your order to your Visa or MasterCard. Please include \$2.00 shipping and handling on all orders. California residents please add sales tax. Allow three weeks for delivery. Add \$5.00 for next-day shipment by U.P.S.; \$15.00 for next-day delivery by U.P.S. We guarantee your satisfaction for 90 days with our products, and offer a money-back guarantee if not fully satisfied during that period.

COMPUTEL PUBLISHING SOCIETY
6354 VAN NUYS BLVD., SUITE 161 / VAN NUYS, CA 91401-2696

YES, I'm interested in making my computer talk. Please send me the following items:

- INTRODUCTORY PACKAGE \$ 9.95
- WORDMAKER \$ 19.95
- MESSAGE TALKER \$ 14.95
- ARTIFICIAL INTELLIGENCE. \$ 24.95
- COMPLETE COLLECTION SET. \$ 59.50
- One year subscription to Computel, plus four Kilobaud Monster items . . . \$ 65.50

PLEASE ADD \$2.00 SHIPPING & HANDLING TO YOUR ORDER.

CREDIT CARD _____ EXP. DATE _____

NAME _____

ADDRESS _____

CITY _____ STATE _____ ZIP _____

Your Computer _____

SEND ALL PAYMENT IN U.S. FUNDS DRAWN ON U.S. BANKS • SORRY, NO C.O.D.'S
Make checks payable to: **COMPUTEL PUBLISHING SOCIETY**
Post Office Drawer 7765 / VAN NUYS, CA 91409-7765

Build a Burglar Alarm

Control an alarm system with your Commodore 64

The Commodore 64 user port is a versatile, easily accessible serial and/or parallel interface. Features such as interval timers, handshake control of the parallel and serial interface, maskable interrupts, and a time-of-day clock with a programmable alarm can be used to control devices in the outside world. This article discusses the hardware and software necessary to control the parallel interface so you can construct a burglar alarm system that can be used in your home.

Figure 1 shows the internal circuits of the Commodore 64 which control the user port. Main control of the port is through IC U1 and IC U2. These are 6526 complex interface adapters (CIA's). The user controls these IC's by programming 16 internal registers for the operation needed.

The parallel interface on the user port is labeled PB0-PB7. This is port B of IC U2. These eight signal lines can be individually programmed to be inputs or outputs. The direction of the data is determined by the corresponding bit in the data direction register. Setting a bit position assigns it as an output. Resetting a bit position assigns it as an input.

As an example, storing 255 decimal in the data direction register sets all bit positions, assigning each bit as an output, but storing 15 decimal in the data direction register sets the four least significant bits, and reset the four most significant bits. This assigns the four least significant bits (PB0-PB3) as outputs, and the four most significant bits (PB4-PB7) as inputs.

Writing to or reading from port B is accomplished by poking or peeking the peripheral data register from BA-

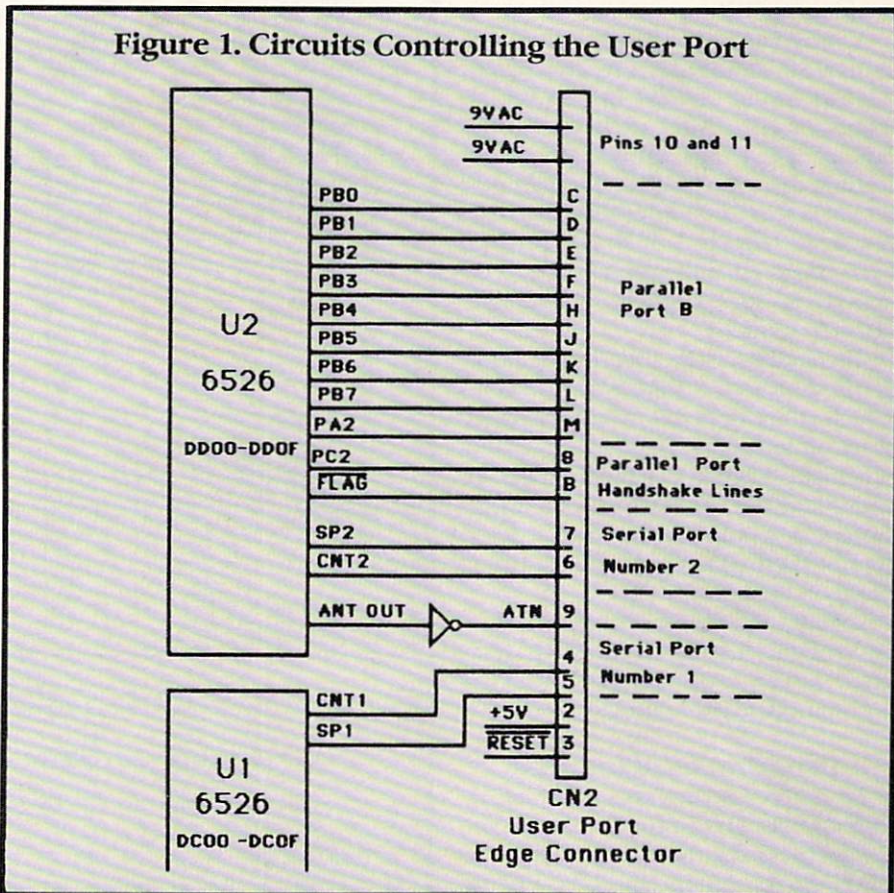

Table 1. Internal Registers of U2

DECIMAL	HEX	REGISTER	REGISTER
56576	DD00	PRA	PERIPHERAL DATA REGISTER A
56577	DD01	PRB	PERIPHERAL DATA REGISTER B
56578	DD02	DDRA	DATA DIRECTION REGISTER A
56579	DD03	DDRB	DATA DIRECTION REGISTER B
56580	DD04	TA	TIMER A LOW REGISTER
56581	DD05	TA	TIMER A HIGH REGISTER
56582	DD06	TB	TIMER B LOW REGISTER
56583	DD07	TB	TIMER B HIGH REGISTER
56584	DD08	TOD	TIME OF DAY CLOCK 10TH OF SECONDS REGISTER
56585	DD09	TOD	TIME OF DAY CLOCK SECONDS REGISTER
56586	DD0A	TOD	TIME OF DAY MINUTES REGISTER
56587	DD0B	TOD	TIME OF DAY HOURS REGISTER
56588	DD0C	SDR	SERIAL DATA REGISTER
56589	DD0D	ICR	INTERRUPT CONTROL REGISTER
56590	DD0E	CRA	CONTROL REGISTER A
56591	DD0F	CRB	CONTROL REGISTER B

SIC, or loading (LDA,LDX) and storing (STA,STX) in machine language after the data direction register bits have been assigned.

Table 1 shows the addresses of the internal registers of U2. Note the addresses for the data direction registers, and the peripheral data registers for ports A and B. We will program these registers to control the alarm system.

Parallel port B signals will be used to control a multiplexer sensing the condition of switches physically at-

tached to windows and doors in our burglar alarm system, and one signal from parallel port A (PA2) will control the audible alarm.

Figure 2 is the schematic of the alarm system. The alarm system is capable of sensing the state of 16 switches. The switches are physically mounted on the windows and doors selected to sense intrusions. If a door or window is opened, the corresponding switch contacts will close, causing a ground potential to be felt on one of

the inputs of IC1.

A program in the Commodore 64 scans all 16 inputs of IC1 by generating a binary count on PB0-PB3 (A,B,C,D inputs of IC1). After each count the output of IC1 (pin 10) is checked by reading the state of PB4. If a high potential is sensed on PB4, the alarm has not been triggered. If the alarm has been triggered, a low potential is generated on PA2 causing the audible alarm to sound.

The audible alarm used in this project is similar to a smoke alarm siren, which is not desirable when trying to scare off intruders. Figure 3 shows the schematic diagram of a more powerful siren, and the interface to our alarm system. I would recommend at least two of these sirens placed in strategic places in the home.

Listing 1 is a simple program used to control the alarm system. This program can be expanded very easily to accommodate your particular needs.

Program Explanation

Line 10 pokes or writes a decimal 15 (binary 00001111) into the data direction register for the B port. This sets PB0-PB3 to outputs, and PB4-PB7 to inputs. Referring to the schematic of the alarm system (Figure 2), PB0-PB3 signals are used to generate a binary count (0000 to 1111) on the inputs of the multiplexer. The multiplexer outputs a signal on pin ten (OUT) that represents the condition of the switch selected by the binary count.

Line 15 pokes or writes the previously stored data from the data direction register from port A, after logically ORing the eight-bit value with four decimal, back into the data direction register. This instruction sets PA2 to an output without changing the state of the other signals on port A (PA0,PA1,PA3-PA7). This is necessary since these other signals control the serial bus interface, and should not be disturbed. Referring to the schematic of the alarm system, we can see the audible alarm is connected between the PA2 output, and the +5VDC supply. The alarm will turn on when the output PA2 goes low. Line 50 in the program activates the alarm.

Line 20 is the loop generating the binary count from 0 to 15. This will select one of the 16 inputs (E0-E15) of the multiplexer when it is written into

Figure 2. Alarm System Schematic

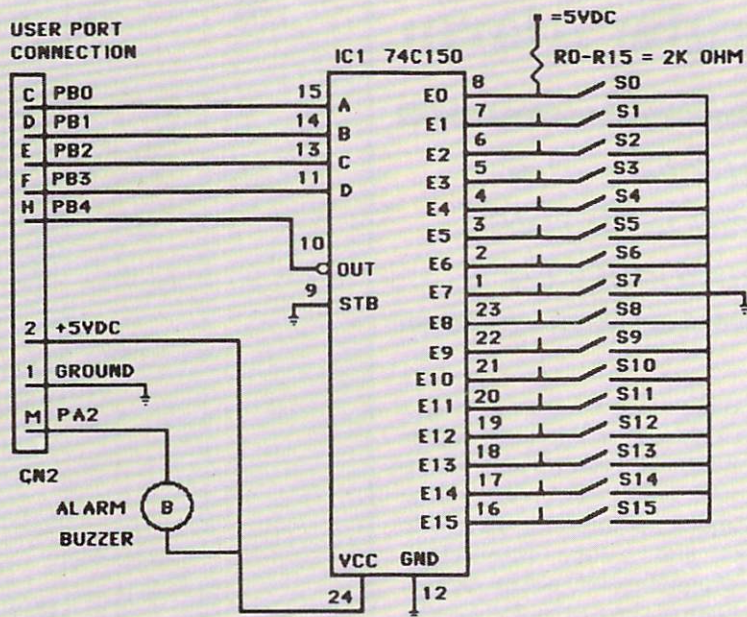

E0 - E15 INPUTS ARE CONNECTED TO A 2K OHM PULL UP RESISTOR.

S0-S15 ARE NORMALLY OPEN ALARM SWITCHES.

PARTS LIST

- 1 FEMALE 24 PIN PCB EDGE CONNECTOR .156 SPACING
- 1 74150 DATA SELECTOR/MULTIPLEXER
- 16 2K OHM RESISTORS 1/4 WATT
- ALARM SWITCHES (NORMALLY OPEN) RADIO SHACK 49-512
- 1 AUDIBLE ALARM RADIO SHACK 273-068

Figure 3. Siren Schematic

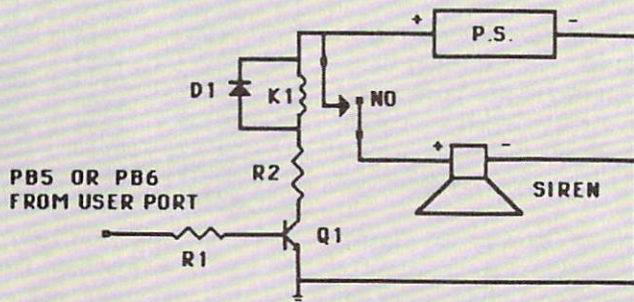

PARTS LIST

- 1 POWER SUPPLY 12VDC @ 1 AMP
- 1 SIREN RADIO SHACK 49-488C
- 1 MINIATURE RELAY K1 RADIO SHACK 275-246
- 1 GENERAL PURPOSE DIODE D1 1N4001
- 1 RESISTOR R2 100 OHM 1 WATT
- 1 RESISTOR R1 3K OHM 1/4 WATT
- 1 2N2222A NPN TRANSISTOR Q1

TECHNICAL TIPS

the peripheral data register B in line 30.

Line 30 pokes or writes the binary count into the peripheral data register B.

Line 40 peeks or reads the peripheral data register B, after logically ANDing the eight-bit value with 16 decimal. This senses the condition of the input selected (E0-E15) by the count developed on line 20. If the value read was 16 decimal, the switch connected to the selected input has been electrically closed, indicating an intrusion.

Line 45 provides a delay before activating the alarm in the case of a normal entrance. The delay time can be varied by changing the count of c in the loop on line 90. Any switch can be used to enable the delay by changing the value of b = 15 in this line. As an example, the switch used to sense an intrusion from the front door would be connected to E15 input of the multiplexer, so if a normal entrance occurred from the front door, the delay would allow time for the program to be stopped before the alarm is activated.

Line 50 activates the alarm when PA2 output goes low. This is done by poking or writing an eight-bit value previously read from the peripheral data register B, logically ANDed with 251 decimal, back into the same register. The value 251 decimal (11111011 binary) will cause PA2 to go low.

Line 55 ends the program if alarm is activated.

Line 60 increments the count which selects the next input on the multiplexer.

Line 70 jumps to line 20 after the count reaches 15, resetting the count to zero and starting the scan again.

Line 90 is the delay for normal entrance. Delay time can be varied by changing the count value.

Constructing the Alarm

Let's discuss some details that can be easily overlooked while constructing the alarm system. Refer to the alarm system schematic. Connections to the 64 user port are made through a 24-pin edge connector. It is very easy to insert this upside down. When looking from the rear of the 64 at the user port opening, the top, from left to right, is pins 1 to 12. The bottom,

Listing 1. Alarm Control Program

```
10 POKE 56579,15:REM SETS PB0-PB3 TO
   OUTPUT, PB4-PB7 TO INPUTS'CTVJ
15 POKE 56578,PEEK(56578) OR 4
   :REM PA2 IS MADE AN OUPUT'EGQM
20 FOR B=0 TO 15'DEYA
30 POKE 56577,B:REM GENERATES BINARY
   COUNT ON PB0-PB3'CMYK
40 A=PEEK(56577)AND 16:REM SENSES
   STATE OF INPUT SELECTED BY
   COUNT'ETOO
45 IF A=16 AND B=15 THEN 90
   :REM JUMP TO DELAY IF ALARM WAS
   TRIGGERED BY SW 15'GURV
50 IF A=16 THEN POKE 56576,
   PEEK(56576)AND 251:REM ALARM HAS
   BEEN TRIGGERED'HQOP
55 IF A=16 THEN END'EDMJ
60 NEXT B'BBUC
70 GOTO 20'BCJD
90 FOR C=1 TO 500000:NEXT C
   :REM DELAY FOR NORMAL ENTRANCE'FIQQ
100 GOTO 50'BCMU
```

Parts from Radio Shack

30-GAUGE WIRE
50-Ft. Spools
Red
278-501
2.39
WIRE WRAPPING TOOL
Includes Handy Wire Stripper
276-1570
5.95
16-POSITION DIP HEADER
With cover.
276-1980
1.69
WRAP DIP SOCKETS
Posts accept 3 levels of wrap.
16
276-1994
1.39
GRID BOARDS
4 1/2 x 6 3/4"
2200
276-147
2.99
PULSING/CONTINUOUS PIEZO
BUZZER
273-068
6.95
DUAL-ROW BARRIER STRIPS
2
274-656
2 for 1.29

Figure 4. Alarm System PC Board Layout

- 1,2 Barrier or Terminal Strip
- 3,4 16 Pin Wire Wrap IC Sockets with
16 Position Dip Header inserted. 8 2k Ω Resistors
Soldered to Dip Header
- 5 24 Pin Wire Wrap Socket for 74150 IC

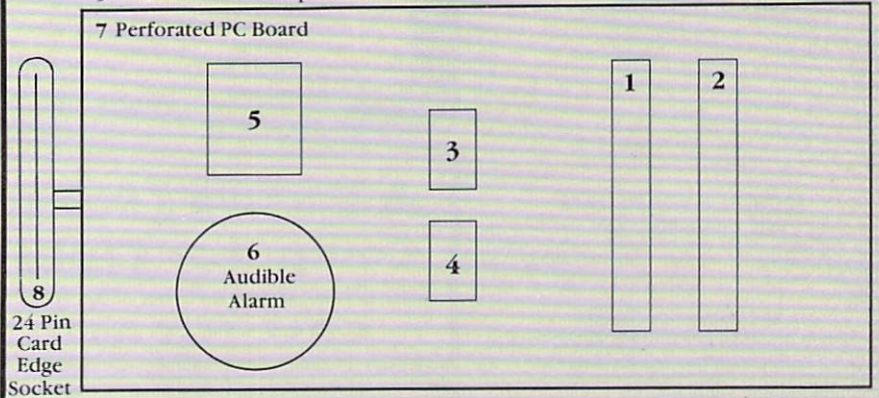

from left to right, is pins A to N, skipping pins G and I.

I have shown switches S0-S15 connected to the inputs on the multiplexer IC 1. Each input is also connected to a 2K-ohm pull-up resistor. The actual switch is physically mounted at the door or window being monitored for an intrusion. Two wires will have to be run to each switch used. One wire from the switch connects to the multiplexer input, while the other wire is connected to the 64 common ground.

All the alarm system components can fit very easily on a small pre-drilled PC board. Connections between components should be wire-wrapped using 30-gauge wire. Wire-wrap sockets for IC's and wire-wrap header plugs for pull-up resistors should be used to simplify the construction. Twenty-two gauge wire should be used to connect the switches at the doors and windows to a terminal strip mounted on the PC board. Figure 4 shows a layout of the alarm system. C

COMMODORE 64

* with \$19.95 Software Purchase

\$ 139⁰⁰*

- 170K Disk Drive \$149.00 *
- Tractor Friction Printer \$159.00
- 13" Hi-Res Color Monitor \$179.00 *

COMPUTER AND SOFTWARE SALE

CALL BEFORE YOU ORDER

PRICES MAY BE LOWER

C128 COMMODORE COMPUTER

(Coming Soon — Order Now)

\$ 299⁰⁰*

- Computer Learning Pad \$37.95
- Voice Synthesizer \$49.00
- 12" Green or Amber Monitor \$79.95
- 12" Daisy Wheel Printer \$199.00

SPECIAL SOFTWARE COUPON

We pack a SPECIAL SOFTWARE DISCOUNT COUPON with every COMMODORE 64 COMPUTER, DISK DRIVE, PRINTER, or MONITOR we sell! This coupon allows you to SAVE OVER \$500 OFF SALE PRICES!!

(Examples)

PROFESSIONAL SOFTWARE COMMODORE 64

Name	List	Sale	Coupon
Paperback Writer 64	\$99.00	\$39.00	\$29.95
Paperback Data Base	\$69.00	\$34.95	\$24.95
Paperback Dictionary	\$24.95	\$14.95	\$10.00
Practical II	\$69.95	\$49.95	\$44.95
Print Shop (Disk)	\$44.95	\$32.95	\$26.95
Practical	\$59.95	\$24.95	\$19.95
Programmers Reference Guide	\$20.95	\$16.95	\$12.50
Programmers Helper (Disk)	\$59.95	\$29.95	\$19.95
80 Column Screen (Disk)	\$59.95	\$29.95	\$19.95
Disk Filer (by Flip-N-File)	\$39.95	\$14.95	\$12.95
Deluxe Tape Cassette	\$89.00	\$44.95	\$34.95
Pro Joy Stick	\$19.95	\$12.95	\$10.00
Light Pen	\$39.95	\$14.95	\$ 9.95
Dust Cover	\$ 8.95	\$ 6.95	\$ 4.60
Simon's Basic	\$29.95	\$22.95	\$19.95
Pitstop II Epyx	\$39.95	\$24.95	\$19.95
Super Graphics Expander	\$29.95	\$22.95	\$19.95
Music Calc I	\$59.95	\$29.95	\$24.95
Filewriter	\$59.95	\$29.95	\$24.95

(See over 100 coupon items in our catalog)

Write or call for Sample SPECIAL SOFTWARE COUPON!

* C128 COMMODORE COMPUTER \$299.00

We expect a limited supply the 1st week in July. We will ship on a first order basis. This all-new revolutionary 128K computer uses all Commodore 64 software and accessories plus all CPM programs formatted for the disk drive. List \$349.00. **SALE \$299.00.**

SUPER AUTO DIAL MODEM \$59.00

Easy to use. Just plug into your Commodore 64 computer and you're ready to transmit and receive messages. Easier to use than dialing your telephone. Just push one key on your computer! Includes exclusive easy to use program for up and down loading to printer and disk drives. **Best in U.S.A.** List \$129.00. **SALE \$59.00.**

COMPUTER LEARNING PAD \$37.95

Makes other graphics tablets obsolete. This TECH SKETCH LEARNING PAD allows you to draw on your T.V. or Monitor and then you can print whatever you draw on the screen on your printers. FANTASTIC!!! List \$79.95. **SALE \$37.95.**

VOICE SYNTHESIZER \$49.00

For Commodore-64 computers. Just plug it in and you can program words and sentences, adjust volume and pitch, make talking adventure games, sound action games and customized talkies!! FOR ONLY \$19.95 you can add TEXT TO SPEECH, just type a word and hear your computer talk — ADD SOUND TO "ZORK", SCOTT ADAMS AND OTHER ADVENTURE GAMES!! (Disk or tape.)

12" GREEN OR AMBER MONITOR \$79.95

Your choice of green or amber screen monitor, top quality, 80 columns x 24 lines, easy to read, anti-glare! PLUS \$9.95 for connecting cable. Com-64 or VIC-20.

PRINTER/TYPEWRITER COMBINATION \$249.00

"JUKI" Superb letter quality, daisy wheel printer/typewriter combination. Two machines in one — just a flick of the switch. 12" extra large carriage, typewriter keyboard, automatic margin control and relocate key, drop in cassette ribbon! (90 day warranty) centronics parallel or RS232 serial port built in (Specify). List \$349.00. **SALE \$249.00.** (Ltd. Qty.)

CARDCO G+ INTERFACE \$59.00

For Commodore 64 and Vic 20 computers. Lets you use other printers with Centronics interfaces. This interface lets the printer act like a Commodore printer including printing the Commodore graphics (Dot matrix with graphic capability printers). List \$109.00. **SALE \$59.00.**

* COMMODORE 64 COMPUTER \$139.00

You pay only \$139.00 (with the \$19.95 software purchase, see below) when you order the powerful 84K COMMODORE 64 COMPUTER! LESS the value of the SPECIAL SOFTWARE DISCOUNT COUPON we pack with your computer that allows you to SAVE OVER \$500 off software sale prices!! With only \$100 of savings applied, your net computer cost is \$39.00!!

* 170K DISK DRIVE \$149.00

You pay only \$149.00 (with the \$19.95 software purchase, see below) when you order the 170K Disk Drive! LESS the value of the SPECIAL SOFTWARE DISCOUNT COUPON we pack with your disk drive that allows you to SAVE OVER \$500 off software sale prices!! With only \$100 of savings applied, your net disk drive cost is \$49.00.

* 13" HI-RES COLOR MONITOR \$179.00

You pay only \$179.00 (with the \$19.95 software purchase, see below) when you order this 13" COLOR MONITOR with sharper and clearer resolution than any other color monitors we have tested! LESS the value of the SPECIAL SOFTWARE DISCOUNT COUPON we pack with your monitor that allows you to save over \$500 off software sale prices!! With only \$100 of savings applied, your net color monitor cost is only \$79.00. (16 Colors).

80 COLUMN 80 CPS

TRACTION/FRICTION PRINTER \$159.00

You pay only \$159.00 when you order the Comstar T F deluxe line printer that prints 8 1/2 x 11 full size, single sheet, roll or fan fold paper, labels, etc. Impact dot matrix, bidirectional, LESS the value of the SPECIAL SOFTWARE DISCOUNT COUPON we pack with your printer that allows you to SAVE OVER \$500 off software sale prices!! With only \$100 of savings applied your net printer cost is only \$59.00.

80 COLUMN BOARD \$79.00

Now you program 80 COLUMNS on the screen at one time! Converts your Commodore 64 to 80 COLUMNS when you plug in the 80 COLUMN EXPANSION BOARD!! PLUS 4 slot expander and word processor!

80 COLUMNS IN COLOR

PAPERBACK WRITER 64 WORD PROCESSOR \$39.00

This PAPERBACK WRITER 64 WORD PROCESSOR is the finest available for the COMMODORE 64 computer! The ULTIMATE FOR PROFESSIONAL Word Processing. DISPLAYS 40 or 80 COLUMNS IN COLOR or black and white! Simple to operate, powerful text editing, complete cursor and insert delete key controls line and paragraph insertion, automatic deletion, centering, margin settings and output to all printers! List \$99.00. **SALE \$39.00** Coupon \$29.95

ATTENTION Computer Clubs

We Offer Big Volume Discounts

CALL TODAY!

*The \$19.95 Software Purchase Options

	LIST	SALE
1. 24 Program Bonus Pack (tape or disk)	\$29.95	\$19.95
2. Oil Barrons-Strategy Board Game	\$49.95	\$19.95
3. Disk Drive Cleaner	\$29.95	\$19.95
4. HES Games (disk)	\$29.95	\$19.95
5. Pogo Joe (tape or disk)	\$29.95	\$19.95

- LOWEST PRICES • 15 DAY FREE TRIAL
- BEST SERVICE IN U.S.A. • ONE DAY EXPRESS MAIL

PHONE ORDERS
8 a.m. - 8 p.m. Weekdays
9 a.m. - 12 noon Saturdays

- 90 DAY FREE REPLACEMENT WARRANTY
- OVER 500 PROGRAMS • FREE CATALOGS

Add \$10.00 for shipping, handling and insurance. Illinois residents please add 6% tax. Add \$20.00 for CANADA, PUERTO RICO, HAWAII, ALASKA, APO-FPO orders. Canadian orders must be in U.S. dollars. WE DO NOT EXPORT TO OTHER COUNTRIES EXCEPT CANADA. Enclose Cashiers Check, Money Order or Personal Check. Allow 14 days for delivery, 2 to 7 days for phone orders, 1 day express mail! VISA — MASTER CARD — C.O.D. No C.O.D. to Canada, APO-FPO

PROTECTO

We Love Our Customers

22292 N. Pepper Rd., Barrington, Illinois 60010

312/382-5244 to order

Circle Reader Service No. 20

FANTASTIC COMPUTER PRINTER SALE!!!

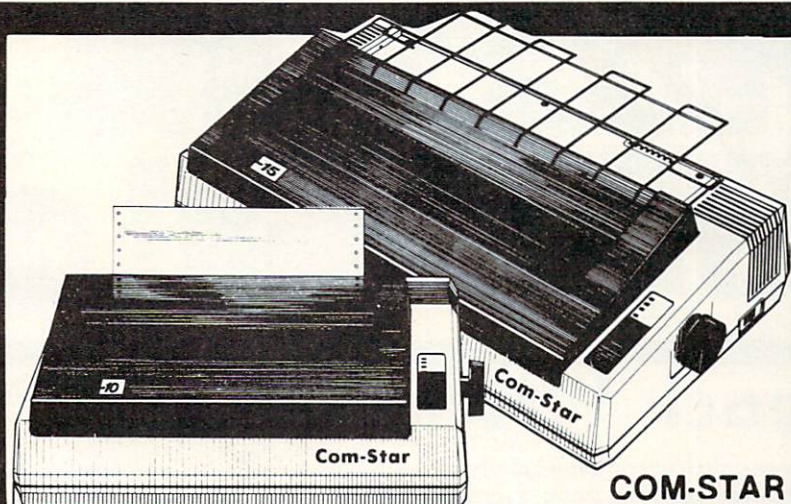

**10X COM-STAR*
HIGH SPEED**

Tractor Friction Printer

130-150 CPS

Only

\$199

List \$499

15 1/2" 150-170 CPS Printer \$319⁰⁰

- **Lowest Sale Price, Premium Quality, Tractor/Friction Printer in the U.S.A. (Best Value)**
- **High Speed 130-150 Characters Per Second • 40, 46, 66, 80, 96, 132 line spacing**
- **Word Processing, Letters • Business Forms • Labels, Graphics, Tables • List Programs**
- **Fantastic Graphics • Print Modem Data • The Most Important Accessory For Your Computer**

**Premium Quality
130-150 CPS 10X COM-STAR
High Speed Printer \$199**

10" carriage, 2K buffer, prints 8 1/2"x11" standard single sheet or continuous feed paper, Bi-directional, impact, dot matrix, 130-150 CPS, 9 x 9 dot matrix with double strike capability for 18 x 18 dot matrix (near letter quality), high resolution bit image, underlining, downloadable characters, true lower descenders with super and subscripts, prints standard, block graphics, and special characters. It gives you print quality and features found on printers costing twice as much!! (Centronics Parallel Interface) (Better than Epson FX80 and Gemini 10x).

List \$499.00. Sale \$199.00.

**Premium Quality 150-170 CPS
15 1/2" X COM-STAR Business
Super High Speed Printer \$319.00**

Has all the features of the 10X COM-STAR PRINTER plus 15 1/2" carriage and more powerful electronics components to handle large ledger business forms! (Better than Epson FX 100 & Delta 15).

List \$599. Sale \$319.00.

JUKI®

**12" DAISY WHEEL
PRINTER \$199.00**

"JUKI" Superb letter quality daisy wheel printer, 12" extra large carriage, up to 12CPS bi-directional printing, drop-in cassette ribbon, (90 day warranty) centronics parallel or RS232 serial port built in! (Specify).

Limited Quantities.
List \$299.00. Sale \$199.00.

JUKI®

**Printer/Typewriter
Combination \$249.00**

"JUKI" Superb letter quality, daisy wheel printer/typewriter combination. Two machines in one — just a flick of the switch. 12" extra large carriage, typewriter keyboard, automatic margin control and relocate key, drop in cassette ribbon! (90 day warranty) centronics parallel or RS232 serial port built in (Specify).
List \$349.00. Sale \$249.00.

Olympia

**Executive Letter Quality \$339.00
15" Daisy Wheel Printer**

This is the world's finest daisy wheel printer. Fantastic letter quality, up to 20 CPS bi-directional, will handle 14.4" forms width! Has a 256 character print buffer, special print enhancements, built in tractor-feed (Centronics Parallel and RS232C Interface) (90 day warranty).

List \$649.00. Sale \$339.00

Olympia

Printer/Typewriter Combination \$439.00

Better than IBM Selectric. Superb computer printer combined with the world's finest electronic typewriter. Two machines in one, just flick the switch for up to 20 CPS printing (300 Words per minute) on a 15" carriage that handles up to 14 1/8" in. paper. Drop in cassette ribbon — express lift off correction, Centronics parallel interface (90 day warranty).

List \$749.00. Sale \$439.00.

• 15 Day Free Trial — 1 Year Immediate Replacement Warranty

PARALLEL INTERFACES

For VIC-20 and COM-64 — \$59.00. Apple — \$59.00. Atari — \$59.00.

Add \$14.50 for shipping, handling and insurance. Illinois residents please add 6% tax. Add \$29.00 for CANADA, PUERTO RICO, HAWAII, ALASKA. APO-FPO orders. Canadian orders must be in U.S. dollars.

WE DO NOT EXPORT TO OTHER COUNTRIES, EXCEPT CANADA.

Enclose Cashiers Check, Money Order or Personal Check. Allow 14 days delivery. 2 to 7 days for phone orders. 1 day express mail!

VISA — MASTERCARD — C.O.D. No C.O.D. to Canada or APO-FPO

PROTECTO

We Love Our Customers

22292 N. Pepper Rd., Barrington, Illinois 60010

312/382-5244 to order

☆☆ NEW ☆☆

Commodore - 64

☆☆ NEW ☆☆

WORD PROCESSING BREAKTHROUGH!

SALE

SALE

40 or 80 Columns
in Color

Paperback Writer 64

40 or 80 Columns
in Color

This is the easiest to use and most powerful word processor available for the Commodore 64. As you type on the screen, you will see your letters and words appear on the screen exactly as they will be printed (i.e. Italics will be *Italic*, Bold Face will be **Bold Face**). With the printer files you can customize Paperback Writer 64 to use all the fancy features of your printer. Loads EZ Script®, Paperclip®, & Wordpro 64® Files so you can easily upgrade your past wordprocessing text that you've written with obsolete wordprocessors.

Take a look at some of the other features:



- **Wordwrap** — No Words Break At The Edge Of The Screen.
- **Flexible Cursor Movement**, Including Tabs And Other Timesavers.
- **Deletion And Insertion** Of Characters, Lines And Blocks Of Text.
- **On-screen Text Enhancement**, Such As Bold Face, Italics, Underlining, Superscripts And Subscripts, And Foreign And Other Characters.
- **Manipulation Of Blocks (ranges)** Of Text For Functions Such As Moving And Deleting, Even Between Files.
- **Sorting Lists** In Order Of Numbers And Letters.
- **Aligning And Adding Numbers** In Columns, Helpful With Tables.
- **Variable Margins** At Left And Right, And Paragraph Indentation.
- **Lines Centered, Justified Or Aligned** At The Right Side.
- **Variable Page Lengths And Line Spacing**.
- **Borders** At Top Or Bottom With Optional Title Lines And Page Numbers.
- **Linked Files** To Print Extra-long Documents In Sequence.
- **Flexible Printer Set-up** To Allow Use With Any Printer.
- **Find And Replace** Text Functions That Can Be Automatic.
- Complete Or Selective **Directories** Of Files On The Disk.
- **Sequential Files** For Mail Lists And Communication With Other Computers.
- **Spelling Checker**, Checks Your Spelling.

INTRODUCTORY PRICE

\$39.95

DOUBLE PROTECTO FREE TRIAL

We are so sure this is the easiest and most powerful word processor available, we will give you 30 days to try it out. If you are not completely satisfied, we will refund your purchase price.

☆☆☆ Plus ☆☆☆

Full help screens on line with additional help on the disks mean you don't even need a manual. If you're in the middle of a page and you want to know how to use a special function just hit F7 and the information will appear before your eyes. If you still don't understand hit F7 again and a more detailed explanation appears. Then simply hit F8 and you're back in the letter where you left off. No manual lookup necessary. This is the easiest word processor in the world to use.

List \$99.00. **Introductory Sale Price \$39.95.**

PAPERBACK DATABASE List \$69.00. **Sale \$34.95.** * *Coupon \$24.95.*

Add \$3.00 for shipping, handling and insurance. Illinois residents please add 6% tax. Add \$6.00 for CANADA, PUERTO RICO, HAWAII, ALASKA. APO-FPO orders. Canadian orders must be in U.S. dollars. WE DO NOT EXPORT TO OTHER COUNTRIES EXCEPT CANADA.

Enclose Cashiers Check, Money Order or Personal Check. Allow 14 days for delivery, 2 to 7 days for phone orders, 1 day express mail!

VISA — MASTER CARD — C.O.D.

No C.O.D. to Canada, APO-FPO.

PROTECTO

We Love Our Customers

22292 N. Pepper Rd., Barrington, Illinois 60010

312/382-5244 to order

EZ Script™ is a trademark of Commodore Business Machines. Paperclip™ is a trademark of Batteries Included, Inc. & Wordpro 64™ is a trademark of Professional Software, Inc.



80 CPS PRINTER

Smith Corona



• Commodore 64

• 11" Carriage • Friction/Tractor • Graphics

\$159

1 Year
Immediate
Replacement
Warranty



**Tractor Feed
Included FREE!**



**SMITH
CORONA**

The Fastext 80 dot matrix printer from Smith-Corona. A high speed, high flexibility printer with a low suggested manufacturer's retail price of only \$299.00. **Sale \$159.00.** It does your graphics with ease and prints letters with speeds up to **80 CPS.** (*Does Commodore graphics with graphics interface.*) As for flexibility, it has bi-directional printing, friction and tractor feed. Plus six different pitches including condensed and enlarged type for impeccable characters in a variety of sizes. Also standard is a full line buffer and thrifty drop-in ribbon cassettes that yield up to a million characters. Finally, it's compatible with virtually all personal computers. Teamed up with your personal computer, it'll keep track of your transactions, fly through finances, help with homework, even plan the family menu. All this with the assurance of superb Smith-Corona quality built in, makes the Fastext-80 a lot of dot for your dollar. List \$299.00. **Sale \$159.00.**

SPECIFICATIONS:

Size/Weight: Height 4" Width 16.5" Depth 9"
Weight 8.2 lbs.

Electrical Needs: 120V/60Hz
Internal Char. Coding: ASCII&ISO

Print Buffer Size: 132 Bytes (1 line)
No. of Char. in Char. Set: 96 ASCII&
International

Graphics Capability: Standard 60, 72 Dots Per
Inch Horizontal, 72 Dots Per Inch Vertical

Pitch: 10, 12, 16.7, 5, 6, 8.3

Printing Method: Impact Dot Matrix

Char. Matrix Size: (Standard) 9H x 8V,
(Elongate) 10H x 8V
Printing Features: Bi-directional, Short line
seeking
Printing Speed: 80 CPS

PAPER

Type: Plain
Forms Type: Fanfold, Cut Sheet
Max Paper Width: 11"
Feeding Method: Friction Feed Std.; Tractor
Feed Included

RIBBON

Type: Cassette — Fabric inked ribbon
Life: 1 million characters

CHARACTER MODE

Character Font: 9 x 8 Standard, 10 x 8 Elongated,
No. 8 pin to be used for underline
Character Set: 96 ASCII, 11 x 7 International Char.
Pin Graph Mode: The incoming bit pattern
corresponds to the 8 pins in the print head
Resolution: Horizontal: 60, 72 dots/inch, Vertical:
72 dots/inch

PARALLEL INTERFACES

Commodore 64 — \$39.00

Apple II, IIe, II+ — \$59.00

Atari — \$59.00

Add \$10.00 for shipping, handling and insurance. Illinois residents please add 6% tax. Add \$20.00 for CANADA, PUERTO RICO, HAWAII, ALASKA, APO-FPO orders. Canadian orders must be in U.S. dollars. WE DO NOT EXPORT TO OTHER COUNTRIES, EXCEPT CANADA.

Enclose Cashiers Check, Money Order or Personal Check. Allow 14 days for delivery, 2 to 7 days for phone orders, 1 day express mail!

VISA — MASTER CARD — C.O.D.

No C.O.D. to Canada, APO-FPO.

PROTECTO

We Love Our Customers

22292 N. Pepper Rd., Barrington, Illinois 60010

312/382-5244 to order

Circle Reader Service No. 20

COLOR MONITOR

Sale

SALE!!!

16
COLORS

(Premium Quality)

- Built in Speaker and Audio
- Front Panel Controls
- For Video Recorders
- For Small Business Computers
- Apple - Commodore - Atari - Franklin - etc.



(Premium Quality)

- Beautiful Color Contrast
- High Resolution
- Separated Video
- Sharp Clear Text
- Anti-Glare Screen
- 40 Columns x 24 Lines
- Supports 80 Columns

List \$399⁰⁰

SALE \$179⁰⁰**

13" Color Computer Monitor

** with \$19.95 Software Purchase
without Software Purchase \$189.00
*Connecting cable \$9.95

Add \$14.50 shipping, handling and insurance. Illinois residents please add 6% tax. We do not ship to foreign countries (including Canada) Alaska Puerto Rico APO-FPO.

Enclose Cashiers Check, Money Order or Personal Check. Allow 14 days for delivery. 2 to 7 days for phone orders. 1 day express mail!

15 Day Free Trial - 90 Day Immediate Replacement Warranty

14" COMMODORE 1702 COLOR MONITOR

List \$299⁰⁰

SALE \$179⁰⁰*

12" XTRON SUPER HI-RESOLUTION MONITOR

80 Columns x 24 Lines, Super Hi-Resolution 1000 lines Green or Amber Super-Clear "Easy to Read" text with special anti-glare screen!

List \$249⁰⁰

SALE \$119⁰⁰*

12" ZENITH HI-RESOLUTION GREEN OR AMBER TEXT DISPLAY MONITOR

80 Columns x 24 Lines, Hi-Resolution, crisp clear easy to read text with anti-glare screen! A MUST for word processing.

List \$199⁰⁰

SALE \$99⁰⁰*

12" MONITOR GREEN OR AMBER TEXT

80 Columns x 24 Lines, easy to read up front controls

List \$159⁰⁰

SALE \$79⁹⁵*

* Connecting cable \$9.95

• LOWEST PRICES • 15 DAY FREE TRIAL • 90 DAY FREE REPLACEMENT WARRANTY
• BEST SERVICE IN U.S.A. • ONE DAY EXPRESS MAIL • OVER 500 PROGRAMS • FREE CATALOGS

Add \$10.00 for shipping, handling and insurance. Illinois residents please add 6% tax. Add \$20.00 for CANADA, PUERTO RICO, HAWAII, ALASKA, APO-FPO orders. Canadian orders must be in U.S. dollars. WE DO NOT EXPORT TO OTHER COUNTRIES EXCEPT CANADA. Enclose Cashiers Check, Money Order or Personal Check. Allow 14 days for delivery. 2 to 7 days for phone orders. 1 day express mail!
VISA — MASTER CARD — C.O.D. No C.O.D. to Canada, APO-FPO

PROTECTO

We Love Our Customers

22292 N. Pepper Rd., Barrington, Illinois 60010

312/382-5244 to order

NEW

Commodore 64

NEW

One Megabyte

\$199 Disk Drive \$199

Store Spreadsheets, Databases, Wordprocessing Data, Etc.

• Commodore 64 • PET • 8032 • B128

The one megabyte disk keeps you from hunting through hundreds of disks for your programs; plus running out of room on your drive for Data base Data, Word processing Text, Spreadsheet Data, Business program Data, etc. With the One Megabyte Disk Drive you can store over **5½ times the capacity of the 1541**. You can store your own programs and any back-up-able commercial programs plus data from your business programs*. Perfect as a second Drive!!!! Enter the world of professional computers today. *C-64 requires IEEE interface.*

List \$899.00. **Sale \$199.00.**

LIMITED QUANTITIES!

*Requires 2 drive software.

\$299⁰⁰ Sale \$299⁰⁰

**15½" High Speed
150-170 CPS**

BUSINESS PRINTER



The MPP-1361 is a highly advanced 136-250 column 15½" professional tractor/friction printer with full Bit image graphics and downloadable characters for custom reports and program listings. The paper feed includes a multiple pin tractor for smooth error free operation. With the ribbon rated at 1 million characters (no mess cartridge) and the print head at 100 million characters this printer will last a lifetime. Full formatting with near letter quality makes lining up decimal points, automatic "\$" signs and tabbing look fantastic and easy to use. With out a doubt **THIS IS THE BEST PRINTER VALUE IN THE U.S.A.** List \$899.00 **Sale \$299.00.**

LIMITED QUANTITIES!

SPECIFICATIONS

PRINTING METHOD
Serial Impact Dot Matrix

PRINT RATE
150-170 Characters per second (CPS)

PRINT STYLE
Near Letter Quality

PRINT DIRECTION
Bi-directional

COLUMN CAPACITY
136 - 250

LINE SPACING
Programmable

COPIES
3, including original

RIBBON TYPE
Cartridge (\$14.95)

RIBBON LIFE
1 Million Characters

PAPER WIDTH
3" to 15½" tractor or single sheet friction

INTERFACE
IEEE Protocol

CHARACTER SIZE
0.116" high, 0.08" wide

GRAPHICS
Bit Image
Programmable Characters
Reverse Characters

ERROR HANDLING
Internal
Self - Diagnostics
Microprocessor

Commodore 64 IEEE Interface

This interface plugs into your Commodore 64 Disk Drive port and allows you to hook up the 1 Megabyte Disk Drive and MPP-1361 Printer as well as other IEEE devices. Separate power supply insures reliability. Fantastic Interface. (includes all cables) List \$109.95. **If bought with printer or disk drive \$69.00.**

(no interface needed for PET, B-128, and 8032 computers)

Add \$17.50 for shipping, handling and insurance. Illinois residents please add 6% tax. Add \$35.00 for CANADA, PUERTO RICO, HAWAII, ALASKA, APO-FPO orders. Canadian orders must be in U.S. dollars. WE DO NOT EXPORT TO OTHER COUNTRIES EXCEPT CANADA.

Enclose Cashiers Check, Money Order or Personal Check. Allow 14 days for delivery, 2 to 7 days for phone orders, 1 day express mail!

VISA — MASTER CARD — C.O.D.

No C.O.D. to Canada, APO-FPO.

PROTECTO

We Love Our Customers

22292 N. Pepper Rd., Barrington, Illinois 60010

312/382-5244 to order

Circle Reader Service No. 20

Random Thoughts

Randomness in Language

Language is a great place to look for random behavior. It's especially interesting because language leads us into thinking about information, and the connection between information and randomness is deep and valuable.

This column will explore that information-randomness connection and introduce the concept of entropy, a measure of disorder in physical systems. We'll also look briefly at cryptography (the study of code-breaking) and see how it relates to randomness in language. And we'll finish up with a program that takes advantage of the non-randomness of English. I call the program *Textrapolation*. It accepts text that you type in and attempts to predict what will come next, based on patterns that it sees in what has come before.

Entropy and the Second Law

People have always had qualitative ideas about what's disordered and what's orderly. A child's room is chaotic—clothes here, a half-eaten sandwich there, a forgotten (and overdue) library book under the bed, and so on. A crystal is orderly—the same pattern of atoms repeats at regular intervals, which reveals itself to the eye as sharp edges, smooth faces, and regular symmetry of the overall form.

Physicists gradually developed quantitative ways to describe randomness—to assign a number to the amount of chaos in something. The key concept they came up with is called entropy. As a system gets more disordered, its entropy increases. There are laws which apply to entropy. The key law, called the Second Law of Thermodynamics, says that the entropy of an isolated system can never decrease.

In more ordinary language, the Second Law means that once something gets disordered, it won't spontaneously become ordered without out-

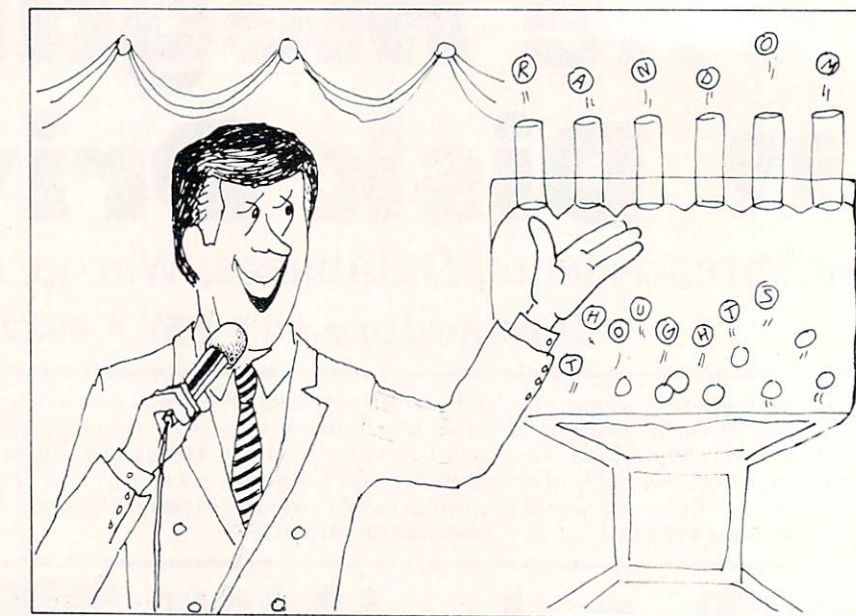

side help. Once a watch runs down and stops, it won't rewind itself. If you mix salt and sugar together, they don't sort themselves out again. Molecules evaporating from a spilled bottle of perfume aren't going to find their way back into the bottle. In other words, everything tends toward a state of maximum disorder.

You may enjoy trying to think of exceptions to the Second Law. Biological systems seem to make order out of chaos: Plants grow and develop from inorganic materials, animals grow and develop by eating plants (or other animals), and "higher" life forms evolve from "lower" ones. If you look closer, though, you'll see that living systems aren't closed off from the outside world. Plants need to take energy from the sun (which is running down), and animals create disorder during their growth.

Mathematical Entropy

What's the formula for the entropy of a system? There are several, but the best equation is based on the probability of finding the system in its various possible states or configurations. Let P_i be the probability of seeing the system in state "i". Then the entropy is just the sum over all states of $-P_i \cdot \text{LOG}(P_i)$, where the LOG function is the natural logarithm that BASIC gives you.

That's a mysterious statement at first glance. What does it really mean? Look at some examples. First, con-

sider a perfectly ordered system, where everything has its place and is in it. Take a deck of cards, as it comes out of the package new. There is only one possible configuration, and the probability is one (certainty) to find the deck in that state. The logarithm $\text{LOG}(1) = 0$, so the entropy $= -P \cdot \text{LOG}(P) = -1 \cdot 0 = 0$. Zero entropy means zero disorder. The entropy of a deck of cards before it's shuffled is zero.

How about after shuffling? There are then 52 choices for the first card, 51 for the second, 50 for the third, etc. Multiplying them all together, the deck as a whole has $52!$ (52 factorial), which is equal to $52 \cdot 51 \cdot 50 \cdot \dots \cdot 3 \cdot 2 \cdot 1$ possible states, all equally likely. This is a big number, approximately $8.0658 \cdot 10^{67}$. For each of these states, the probability P_i is $1/52!$. The logarithm of P_i is about -156 . If you add up all $52!$ terms in the sum of $-P_i \cdot \text{LOG}(P_i)$, you'll get the total entropy $= 156$, a rather large number. There's a lot of disorder in a shuffled deck!

By the way, if you want to compute entropies, there are a couple of calculational tricks you may want to use. First, recall that the logarithm of a product is the sum of the individual logarithms. So, if you want to compute $\text{LOG}(52!)$, just add up $\text{LOG}(52) + \text{LOG}(51) + \text{LOG}(50) + \dots + \text{LOG}(2) + \text{LOG}(1)$. Another equation to keep in mind is Stirling's formula: $\text{LOG}(N!) \approx N \cdot \text{LOG}(N) - N$. Stirling's formula is only approximate, but

TECHNICAL TIPS

it gets more accurate as N gets larger. For $N=52$, the formula gives $\text{LOG}(52!) \approx 153$, not far wrong for such a simple computation.

You may enjoy computing the entropy for other simple systems, such as a tossed coin (where there is a 50-50 chance of heads or tails). If you're really adventurous, you might want to think about the entropy of a realistic physical system, like a box full of gas molecules. The details of the answer there begin to depend on quantum mechanics, a subject too far afield to get into this month.

Information and Entropy

What's the connection between order and communication? It's simple and very direct. The higher the entropy of a system, the more information it can convey.

Think about a single coin. You could use its state (heads or tails) to communicate a single bit of data, zero

or one. That's all. A deck of cards, on the other hand, could be used to convey 52! different messages. (Imagine having a code book, and looking up the message that corresponds to each permutation of the cards.) The potential information content of the deck is far higher, because it has a higher entropy.

The higher entropy of a complicated system gives it the potential to convey more messages, but it also gives it a higher risk of confusion and error, especially if there is a chance of "noise" in reading out the message. However, if we reduce the entropy by refusing to assign messages to all the states of the system, we can use the "spare entropy" to detect and perhaps even correct errors.

A simple example of this is the use of a "parity bit" in data transmission. Instead of allowing all 256 possible eight-bit signals, we can assign only half of them to legal characters. That

liberates one bit, which we can set to zero or one to make the total number of ones in the eight-bit signal be odd. Then, if a single bit gets changed due to noise, we'll notice the mistake and can ask the sender to re-transmit.

More complex examples of error detecting are commonly used where the correctness of data is crucial. In the Cray series of supercomputers, for instance, each 64-bit word has eight extra "parity" bits. Those eight bits allow the computer to detect *and correct* all single-bit errors, and to at least detect all two-bit errors. The detection and correction occurs "on the fly," 80 million or so times per second!

Codes and Entropy

Mathematicians have called the study of information transmission coding theory. A better term might be encoding theory, since the subject is concerned with how to convey information, not hide it. On the other hand, with the connection we made between entropy and information, you can see that entropy might be important in transmitting messages secretly. The goal is to make a message seem to be random, like the arrangement of cards in a shuffled deck.

A great deal of work has been done on the subject of codes, for obvious reasons. Secret communications are essential in military affairs, since if an enemy knows your plans, he can likely defeat them. It's also important to keep secrets in business, so your competitors don't take advantage of you. And especially in these days of electronic banking and wire fund transfers, secure and verifiable communications are crucial. Imagine the havoc that someone could cause by inserting false messages into an interbank computer network!

Codebreaking is also closely connected with the study of information and entropy. Most classical ciphers are vulnerable to studies of patterns in the encrypted messages. For example, a simple substitution (where every occurrence of one letter is changed into another) can be broken by counting letters. E is the most common letter in English, followed by T, then A. There are also common multi-letter combinations, led by TH.

Textrapolation 1

```
10 REM TEXTRAPOLATION 1 -- PREDICTION = SINGLE LETTER, LATEST MATCH
100 DIM A(255) : REM RESERVE SPACE FOR STORING LETTERS SEEN
200 PRINT CHR$(P): REM SHOW PREDICTION ON SCREEN
210 GET X$: IF X$="" GOTO 210: REM WAIT FOR USER TO TYPE A LETTER
220 PRINT CHR$(8);X$: REM BACKSPACE AND THEN PRINT CHOSEN LETTER
300 X1=ASC(X$): N=N+1: IF P=X1 THEN R=R+1: REM CONVERT CHAR, ADD ONE TO COUNTER,
    & IF PREDICTION P IS RIGHT ADD 1 TO SCORE R
400 A(X0)=X1: X0=X1: P=A(X0): REM STORE CHOICE IN TABLE, MOVE TO TEMPORARY
    SPACE, AND MAKE PREDICTION P FOR NEXT LETTER
500 GOTO 200
```

Textrapolation 2/3

```
10 REM TEXTRAPOLATION 2/3 -- PREDICTION = 2 OUT OF 3 CHOICES BEFORE
100 DIM A(255),B(255),C(255): REM RESERVE SPACE FOR STORING LETTERS
200 PRINT CHR$(P): REM SHOW PREDICTION ON SCREEN
210 GET X$: IF X$="" GOTO 210: REM WAIT FOR USER TO TYPE A LETTER
220 PRINT CHR$(8);X$: REM BACKSPACE AND THEN PRINT CHOSEN LETTER
300 X1=ASC(X$): N=N+1: IF P=X1 THEN R=R+1: REM CONVERT CHARACTER, ADD ONE TO
    COUNTER, IF PREDICTION P IS RIGHT ADD 1 TO SCORE R
400 C(X0)=B(X0): B(X0)=A(X0): A(X0)=X1: X0=X1: REM SHIFT IN NEW CHOICE
    INFORMATION
420 P=A(X0): IF B(X0)=C(X0) THEN P=B(X0): REM THIS TRICK SETS P TO THE MAJORITY
    (2 OUT OF 3) CHOICE, OR TO LATEST CHOICE IF ALL 3 DIFFER
500 GOTO 200
```

Textrapolation 123

```
10 REM TEXTRAPOLATION 123 -- SCAN BACK FOR BEST MATCH LENGTH <= 3
100 A$="" : REM 15 BLANKS
120 A$=A$+A$: A$=A$+A$: A$=A$+A$: A$=A$+A$: REM A$ = 240 BLANKS NOW
200 PRINT P$: REM SHOW PREDICTION ON SCREEN
210 GET X$: IF X$="" GOTO 210: REM WAIT FOR USER TO TYPE A LETTER
220 PRINT CHR$(8);X$: REM BACKSPACE AND THEN PRINT CHOSEN LETTER
300 N=N+1: IF P=X$ THEN R=R+1: REM ADD ONE TO COUNTER, IF PREDICTION P IS RIGHT
    ADD 1 TO SCORE R
400 A$=RIGHT$(A$,239)+X$: P=240: REM RECORD LATEST CHOICE, INITIALIZE P BEFORE
    SCAN BACK
500 M=0: FOR I=239 TO 3 STEP -1: IF MID$(A$,I,1)=MID$(A$,240,1) THEN P=I+1: M=1:
    F=1: I=3: REM SCAN BACK FOR SINGLE LETTER MATCH
520 NEXT I: IF M=0 GOTO 900: REM STOP TRYING IF NO MATCH FOUND
540 M=0: FOR I=F-1 TO 2 STEP -1: IF MID$(A$,I,2)=MID$(A$,239,2) THEN P=I+2: M=1:
    F=1: I=2: REM SCAN BACK FOR DOUBLE LETTER MATCH
560 NEXT I: IF M=0 GOTO 900: REM STOP TRYING IF NO MATCH FOUND
580 FOR I=F-1 TO 1 STEP -1: IF MID$(A$,I,3)=MID$(A$,238,3) THEN P=I+3: I=1: REM
    SCAN BACK FOR TRIPLE LETTER MATCH
600 NEXT I
900 P$=MID$(A$,P,1): GOTO 200: REM MAKE PREDICTION
```

Continued next page

Language and Entropy

Why are codes breakable? It's really due to the underlying order of the information being transmitted. Let's apply the concept of entropy to the English language. Begin with the frequency distribution of single letters. If all 26 letters were equally likely, the entropy of a single-letter message would be $-\text{LOG}(1/26) \approx 3.26$, and for a message of N letters the entropy would be $3.26 * N$. But all letters are not equally probable. If you get a table of letter frequencies for English and compute the sum of $P * \text{LOG}(P)$, you'll get a number around 2.3—that is, 30% or so less than the 3.26 of random letters. The exact value depends on the frequency table you consult, and what sort of English text it was based on.

But we can go even farther. Look at the words and sentences of English prose. There is a lot of large scale order in language. If native English speakers are shown text, letter by letter, they can typically predict well over half of the letters before seeing them. In that sense, the entropy of English is less than half of the random 3.26 per letter one might have thought.

In compensation for the redundancy, languages give good error detecting and correcting. That's important for speaking to each other in "noisy" circumstances, and for communicating complicated ideas. But that redundancy tends to "show through" when messages are encrypted, and makes it easier to decode a cipher system. One way to cut down the redundancy (and save some letters in enciphering a message) is to leave out most of the vowels. "Th rcvr cn almst alwys fgr out wht u wr trying to snd, bt it's mch hrdr fr n enemy to decod thn!" You can also leave out spaces between words, omit punctuation, and so forth.

The Extrapolation Project

One fun demonstration of the redundancy of English is a computer program to analyze text. As the words are being typed in, the machine tries to predict the next letter before the human hits the key. Back around 1978 I wrote a simple program to do that. I called it Extrapolation, because it extrapolated text.

The Second Law means that once something gets disordered, it won't become ordered again. In other words, everything tends toward a state of maximum disorder.

I decided to write the program (as much as possible) in plain vanilla BASIC, for transportability and simplicity. My first effort is the Extrapolation 1 program at the end of this article. It simply keeps track of what happened the last time a given letter came along, and predicts that the same thing will happen again. Thus, after seeing the input "THIS I," it will predict that the I will be followed by S, since that was what followed it before. The history of what has been typed in is kept in a big array, A(I), with plenty of slots for all possible character inputs.

As you can see, Extrapolation 1 is quite short and simple. It starts out knowing nothing at all, and always guesses wrong (character CHR\$(0), which is "null") until it gets a bit of experience. But it learns fast! When I tried it out on the first sentence of Lincoln's Gettysburg Address ("Four score and . . . created equal.") it predicted a surprisingly high 13% of the characters before they were typed in! I suspect that on longer English text samples it will tend to achieve between 15% and 20% accuracy.

After I wrote Extrapolation 1 and tried it out, I had to go on to something a bit more sophisticated. My next effort was the following program, Extrapolation 2/3. As the name suggests, the program follows the democratic principle of "majority rules" and predicts the following character on the basis of what happened two times out of three in the past. It has three arrays, A(I), B(I), and C(I), to store the history of the input stream. The program itself is only slightly longer than its more simple-minded predecessor.

When I tried Extrapolation 2/3 out, I was at first disappointed. On the same test which Extrapolation 1 got 13% right, the more complicated program only got about 12% accuracy. Then I realized the problem: Extrapolation 2/3 is smarter in the long run, but a slower learner. Since it begins with empty arrays, it has to see at least two examples of a letter before it will actually start guessing anything plausible. I suspect that for longer text samples Extrapolation 2/3 will significantly outperform the simpler routine, and probably score in the 20% to 25% zone.

Finally, I decided to try a completely different approach. The old program to do "extrapolation" kept track of the previous 256 or so characters typed, and scanned back to find the "best fit" among that string of letters. It then predicted that the future would follow that same pattern.

Thus, if the input text began, "When in the course of human even", a program that scanned back would see that the letter pair "En" had occurred before, in the word "When", and would therefore predict (wrongly) that the next letter should be a space. In longer text samples, the best fit can sometimes predict a whole word, especially common words like "and" or "the".

So, I decided to build a scanning program. For simplicity and speed, I restricted it to look for the best match of three letters or less. The result is Extrapolation 123, listed below. It's significantly more complicated than the other programs shown here, and runs more slowly. (I found that it paused up to a second or two at times before it made a prediction.) But it seems to be more accurate than the other methods.

This final program did quite well on my short preliminary trials; it got 16% accuracy of predictions, and was improving rapidly as it went. I suspect it will approach or exceed 25% predictive capability in longer tests.

Note that you need to give the Extrapolation programs text in all capital letters, with no punctuation marks. Adding lower-case letters to the input would make prediction less accurate. On the other hand, since punctuation is almost always followed by a space,

Continued on page 124



QUESTPROBE™

FEATURING SPIDER-MAN®

By Scott Adams
with art
by Mark Gruenwald
& John Romita

A Marvel Adventure

Listen up, True Believer! The world's premier comics company has joined with the originator of Adventure games to bring you the awesome QUESTPROBE Series: an epic group of home-computer Adventures by Marvel Comics and Scott Adams in which YOU become the greatest Marvel Super Heroes™ characters.

Much more than an arcade game and recommended by educators around the world, an Adventure

PRICE
\$34.95

Diskette based software for your Commodore 64 and Commodore Plus/4.

allows you to move through a wondrous electronic world by entering English commands. In **SPIDER-MAN™** you actually control the intellect of Peter Parker and the amazing might of ol' "Web-Head" himself, **SPIDER-MAN.™** Your objective is twofold: to unlock the riddle of the Chief Examiner and . . . to survive!

Each installment of the QUESTPROBE™ Series is a complete Adventure—you need nothing else but your imagination and a compatible computer. And you don't have to be a Marvel Comics fan to enjoy the fun. For all kids aged 8 to 800! Difficulty level: Moderate.

Marvel Super Heroes, Spider-Man, Doctor Octopus, Mysterio, Madame Web, Sandman, Electro, Lizard, Hydro-Man, Ringmaster and The Chief Examiner and their distinctive likenesses are trademarks of the Marvel Comics Group and are used with permission.

ARTWORK & TEXT: Copyright © 1985, Marvel Comics Group. All Rights Reserved.

GAME DESIGN: Copyright © 1985, Scott Adams, Inc. All Rights Reserved.

Questprobe is a co-owned trademark of the Marvel Comics Group and Scott Adams, Inc.

COMMODORE 
RECREATIONAL SOFTWARE

The Commodore 128 In Pictures

Personal Computer

BY JIM GRACELY



MODEMS

The 1660 and 1670 are two new modems for the Commodore 128. The 1660 is a 300-baud auto-answer/auto-dial modem with a built-in speaker. The 1660 can be used with both rotary and Touch Tone phones. The 1670 is a 1200-baud auto-answer/auto-dial modem with auto baud/parity and a built-in speaker. The 1670 is fully compatible with the Hayes SmartModem.

Since many people have only seen the Commodore 128 by itself, here is an intimate look at an entire Commodore 128 system. The system includes the Commodore 128, the 1571 disk drive, the 1902 monitor, the 1670 modem, and of course, the Commodore mouse.

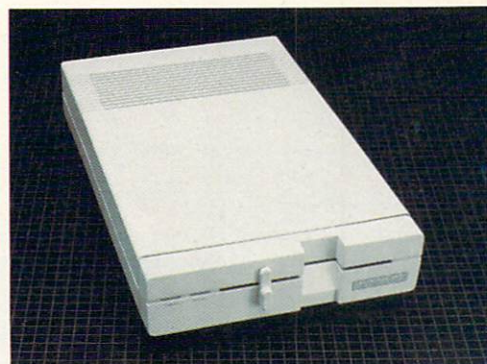

1571 DISK DRIVE

The 1571 is a new double-sided, serial disk drive for the Commodore 128 capable of operating in three different modes. In the Commodore 64 mode the 1571 acts like a 1541 disk drive, with a data-transfer rate of 320 characters per second (cps). When operating in the Commodore 128 mode, the 1571 transfers data at a maximum of 5200 cps with a disk capacity of 360K (formatted). When the 1571 is in CP/M mode, it can read and write IBM System 34 formatted disks with a transfer rate of 5200 cps and a disk capacity of 410K (formatted).

1902 MONITOR

The 1902 is a new RGBI/composite/separated video monitor for the Commodore 128. It provides both 40- and 80-column displays with bandwidths of 4MHz (40 columns) and 10-15MHz (80 columns) and a dot pitch of .42 mm. The 1902 has a 13-inch screen with volume, color, tint, brightness and contrast controls along with an RGBI/composite/separated switch, a built-in speaker and an 1/8-inch headphone jack.



Communicating With The Outside World

BY JIM GRACELY

One of the most important aspects of a computer is its ability to communicate with the outside world. The Commodore 128 talks to the outside world through a number of ports and connectors on the back and right side of the keyboard. Any peripheral or external device that communicates with the C128 (either taking or giving information) must do so through the pins of one of these ports.

This picture and accompanying tables list all of these ports and connectors with full pinouts and signal descriptions. Overbars in the type descriptions means the signal is active low. Additional information on these signals and how they can be used will be available in the Commodore 128 Programmer's Reference Guide.

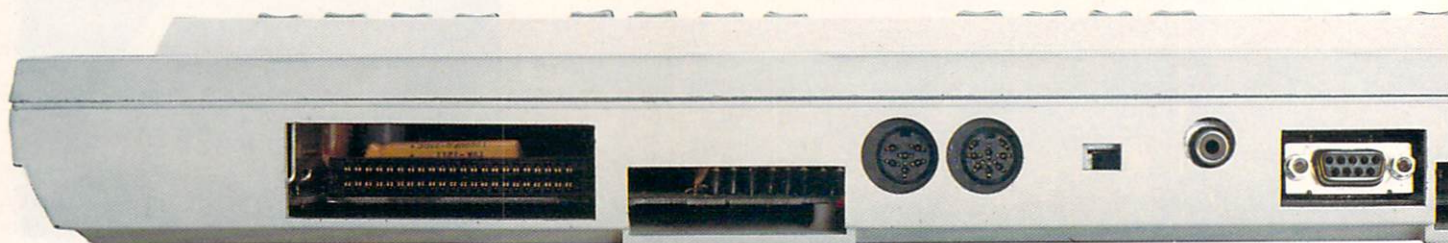

A

B

C

D

E

A CARTRIDGE EXPANSION SLOT

Pin	Type	Pin	Type
1	GND	12	\overline{BA}
2	+5V	13	\overline{DMA}
3	+5V	14	D7
4	\overline{IRQ}	15	D6
5	$\overline{R/W}$	16	D5
6	Dot Clock	17	D4
7	$\overline{I/O 1}$	18	D3
8	\overline{GAME}	19	D2
9	\overline{EXROM}	20	D1
10	$\overline{I/O 2}$	21	D0
11	\overline{ROML}	22	GND

Pin	Type	Pin	Type
A	GND	N	TA9
B	\overline{ROMH}	P	TA8
C	\overline{RESET}	R	**SA7
D	NMI	S	SA6
E	1MHz	T	SA5
F	*TA15	U	SA4
H	TA14	V	SA3
J	TA13	W	SA2
K	TA12	X	SA1
L	TA11	Y	SA0
M	TA10	Z	GND

*T = TRANSLATED **S = SHARED

22 21 20 19 18 17 16 15 14 13 12 11 10 9 8 7 6 5 4 3 2 1



Z Y X W V U T S R P N M L K J H F E D C B A

B CASSETTE

Pin	Type
A-1	GND
B-2	+5V
C-3	CASSETTE MOTOR
D-4	CASSETTE READ
E-5	CASSETTE WRITE
F-6	CASSETTE SENSE

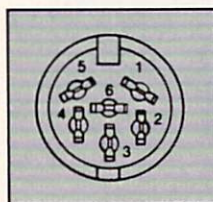
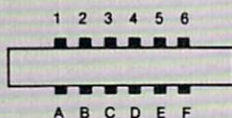

C SERIAL I/O

Pin	Type
1	SERIAL \overline{SRQIN}
2	GND
3	SERIAL ATN IN/OUT
4	SERIAL CLK IN/OUT
5	SERIAL DATA IN/OUT
6	RESET

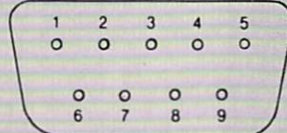



GA

HA

IA

G CONTROL PORT 1

Pin	Type
1	JOYA0
2	JOYA1
3	JOYA2
4	JOYA3
5	POT AY
6	BUTTON A/LP
7	+5V
8	GND
9	POT AX

I POWER

Pin	Type
1	+5 In
2	Shield
3	9 VAC IN
4	SIG GND
5	9 VAC IN

H CONTROL PORT 2

Pin	Type
1	JOYB0
2	JOYB1
3	JOYB2
4	JOYB3
5	POT BY
6	BUTTON B
7	+5V
8	GND
9	POT BX

FA

D AUDIO/VIDEO

Pin	Type
1	LUM/SYNC
2	GND
3	AUDIO OUT
4	VIDEO OUT
5	AUDIO IN
6	COLOR OUT
7	NC
8	NC

F USER I/O

Pin	Type	Pin	Type
1	GND	A	GND
2	+5V	B	FLAG2
3	RESET	C	PB0
4	CNT1	D	PB1
5	SP1	E	PB2
6	CNT2	F	PB3
7	SP2	H	PB4
8	PC2	J	PB5
9	SER. ATN IN	K	PB6
10	9 VAC	L	PB7
11	9 VAC	M	PA2
12	GND	N	GND

E RGBI PORT

Pin	Signal
1	Ground
2	Ground
3	Red
4	Green
5	Blue
6	Intensity
7	Monochrome
8	Horizontal Sync
9	Vertical Sync

VACATION COMPUTING

Ah, summer is upon us, and with it comes thoughts of that long awaited and well deserved vacation. For most folks, vacation means "getting away from it all"—whether it's spent in the "out-back" of your yard or in the outback of Australia. But some of us don't want to get away from it all—we'd like to include computing. Vacations are supposed to be fun, so with that in mind, here are some suggestions.

BY TOM BENFORD



Protect Your Equipment

Whenever you transport your computer equipment, make sure that it is packed safely with plenty of protective padding. There are several cases for computer equipment available, such as the TravelMaster from Southern Case Company, which provide lightweight, sturdy protection.

A less expensive way of packing your equipment is to use the original cartons. These sturdy corrugated boxes and foam-plastic inserts provide excellent protection. If you no longer have the original packing cartons, make sure to use lots of padding. I've found that towels, socks and underwear, in addition to their usual uses, do double duty as "shock absorbers." Since you have to pack this stuff anyway, why not?

Travel insurance is a great way to protect yourself from financial loss in the event of an accident. It's generally

inexpensive and can usually be obtained wherever you purchase your traveler's cheques. Some major credit cards also include this benefit, and often your homeowner's or renter's insurance policy will have travel provisions or make it available for a nominal fee. It's wise to check and see.

Traveling Abroad

If you intend to travel abroad and take your trusty Commodore with you, there are a few things you should keep in mind. First and foremost, there are power considerations, since all electricity is not created equal. The electrical power coming from the wall outlets in your U.S. home is 110-120 volts, AC, 60 cycles. In European countries, however, the voltage is different and the "juice" is usually 50 cycles. Without getting technical, it will suffice to say that your American equipment isn't going to work with European electricity unless you have

some means of converting it. Therefore, you'll have to bring along a voltage adapter.

While we're on the subject, I should mention that your Commodore won't work with the television set in your European hotel either, since their broadcast standard is different from ours. In the U.S., our televisions conform to the NTSC standard, but throughout other countries, either the PAL or SECAM standards are utilized. Therefore, bringing either your own portable television or monitor along is a good idea. While you won't be able to watch the local programs on your meant-for-America television from home, you will be able to display your Commodore's video output on it—provided you have it plugged into a voltage adapter as well. Of course, if you're vacationing with your PET or SX-64 (my favorite traveling companion—besides my wife, that is), both of which have built-in screens, then you



MATT FOSTER

won't have to worry about the TV.

The voltage adapter is a must, however, to use U.S. equipment abroad, so make sure it's on your shopping list. You should be able to purchase a European voltage adapter at any large department store, better hardware store, or luggage shop.

When traveling outside the U.S., you'll have to go through customs. Be sure to declare your computer equipment on the customs declaration when entering the country, or you'll probably have a hassle when it's time to leave. Most entry customs offices will happily oblige and affix a customs stamp to your equipment or provide you with a customs pass. Taking care of customs is very important when you enter a foreign country, since nothing can put the damper on a vacation like a hassle with customs officials.

If you haven't taken care of getting a stamp or pass for your equipment,

If you intend to travel abroad and take your trusty Commodore with you, keep in mind that all electricity is not created equal.

you will have to pay duty on your computer and other gear to take it back home with you or, worse yet, have it confiscated. Whenever I travel to a new destination outside the U.S., I bring along photocopies of sales receipts or other proof of ownership for my equipment. I prefer to carry photocopied receipts, leaving the originals in a safe place.

If you intend to rent a car while vacationing, here's another tip: Rental cars in some locales (like the U.S. Virgin Islands) are easy to identify because of the license plate designations. Don't leave your computer and photo-

graphic gear in the trunk of a rental car without keeping a watchful eye on it. Thieves are wise to the license plates of rentals, and they often find the trunks of these cars to be a treasure-trove of goodies.

Traveling by Air

No matter where your vacation destination is, if you travel by air, you'll have to go through the standard security precautions at the airports. These include having your baggage x-rayed and passing through a metal detector.

Continued on pg. 125

The Electronic Rembrandt

Entertaining Art Software for Your Commodore 64

BY JOYCE WORLEY

*Computer art
software can provide
a shortcut to
artistic expression.*

For novice artists—or even highly experienced ones—the computer is a quick road to artistic self-expression. Someone who barely knows one end of a brush from the other can create attractive drawings within minutes. Here is just some of the computer art software presently available for the Commodore 64.

Paint Magic (Datamost, 19821 Nordhoff Street, Northridge, CA 91324), is an excellent drawing program the whole family can enjoy. It's simple enough for beginners, but boasts special features that make it equally suitable for accomplished painters.

Using the program, you can put freehand drawings on the screen with a joystick-directed cursor. A set of simple keyboard commands allows you to modify the original drawing. Draw rays, circles, and boxes, then fill enclosed areas with solid colors or three different types of striped shading. There is even provision for designing customized fill patterns.

The video painter can transpose a picture from one screen to another, merge two previously separate drawings, or alter the background. A magnification mode lets the artist work pixel by pixel and a slide feature can shift the entire picture. Scenes can be transposed, duplicated, enlarged or reduced. The palette of 16 colors is easy to access and changing the on-screen hues takes only seconds.

Micro Illustrator (Tech Sketch, 26 Just Road, Fairfield, NJ 07006) comes packaged with the Tech Sketch Light Pen. It contains many of the options

found in *Paint Magic*. Selections are made from on-screen menus, using the light pen.

Many users feel more natural "painting" with a light pen than with a conventional joystick, because it's more like a crayon or brush. The Tech Sketch Light Pen is a good introduction to this. The artist need only place the tip of the pen on the desired spot and activate the pen.

The software allows you to draw with ten different brush points in 16 colors or patterns. Special features create straight lines, frames, boxes, circles, discs, or sunburst-rays. Really meticulous craftsmen can super-detail their drawings one pixel at a time, and a mirror option replicates any desired image.

Micro Illustrator lacks certain sophisticated features. For instance, there's no way to move images from place to place, invert them, or alter a scene's colors to fit your changing moods. You can't create new patterns to use as fills. Missing also are the duplication functions which allow the user to "rubber stamp" portions of a drawing.

But the fancy extras are replaced by extreme ease of use. Drawing with a light pen is different than using a joystick-controlled cursor. It does take some practice to create clean smooth

linework with a pen, but it is much more direct.

The *Micro Illustrator* program is exceptionally easy to understand and master. The spacebar toggles the screen between the painting and the menu. All other functions are selected with a touch of the pen.

Although this isn't the program for an accomplished graphics artist, *Micro Illustrator* is fun to use, especially for youngsters who may prefer its simplicity, or anyone who doesn't want to use a joystick to draw.

Designer's Pencil (Activision, 2350 Bayshore Frontage Road, Mountain View, CA 94043) takes a completely different approach. Rather than manipulating a cursor with the joystick or drawing directly on screen with a light pen, *Designer's Pencil* develops artistic computer programs.

Using either the keyboard or joystick-driven cursor, you select a string of computer commands to produce a picture. There are over 80 graphic and musical mini-programs on the menu. The artist compiles a list of instructions that the program executes. The on-screen pencil makes pleasant viewing as it zips back and forth over the display in response to your commands.

The process is simple to learn. To draw a circle, for example, choose the command "Circle R-000" from the list. This tells *Designer's Pencil* to draw a circle. Once you pick the radius, color, and background, the program speedily scribes a circle even a master draftsman would envy. It is also possible to create kaleidoscopic



STEPHEN EARLY

effects by putting mirror images in the four corners of the screen.

Simple musical commands allow the user to add a sound track, if desired. There's virtually no limit to the pictures which can be produced with the extensive menu of commands and some ingenuity. The 12 sample drawings included in the program will get the inspiration flowing.

Drawing this way, instead of directly onto the screen, certainly sounds like a roundabout way to paint. But *Designer's Pencil* is more than a simple paint box program. It teaches how to generate graphics with accompanying sound tracks in much the same way programmers create games, but without the necessity of learning complicated machine language or programming procedures.

Designer's Pencil has special appeal for would-be programmers and hackers, and for users who want some-

***Paint Magic* is simple enough for beginners, but boasts special features that make it equally suitable for accomplished painters.**

thing a little different. Unlike other paint box programs, this one requires absolutely no artistic ability. It depends entirely on the logical sequence of commands to create the images. But it can take some real effort, including much trial and error, to finish a painting. The novice will want to check progress after each command to gauge its effect on the total scene.

Mr. Pixel's Programming Paint Set (Mindscape, 3444 Dundee Road, Northbrook, IL 60062) employs a similar approach. This program, how-

ever, is specifically geared to children ages eight and over. It uses a picture-based programming approach to create art. As with *Designer's Pencil*, the user chooses from a menu of commands and options, then sees the program executed on-screen. An important difference is that the menu presents the options pictorially.

The joystick or keyboard arrows select commands. This method controls the direction of the pencil, selects the color, recreates pictures in new positions, and fills areas with solid hues or

Programs for People Who Can't Draw

If a straight line is beyond your talent, don't despair. Commodore owners have other ways to create computer art.

BY JOYCE WORLEY

Numerous programs contain banks of drawings on disk, along with glitzy pre-drawn backgrounds. By combining these, even an all-thumbs, ham-handed creator can create attractive scenes.



Finally, there are three western tunes on disk to add to the atmosphere. With the shapes and objects in the bank, the user is limited only by his or her imagination.

Movie Musical Madness (CBS Software, One Fawcett Place, Greenwich, CT 06836) lets even a child produce mini-movies. The user chooses to film in color or black-and-white, then selects the stars from a trio of be-boppers called the Jazz Scats. There are over 100 props to decorate the stage, such as skylines, fences, buildings and streetlights. Moving props, like a flying witch, train, and UFO, crisscross the scene. Other objects stay in place, but have animated elements, like the hopping puppy, or the archvillain with his flowing cloak.



Ranch (Spinnaker, One Kendall Square, Cambridge, MA 02139) offers a blank screen and a huge bank of objects, characters, animals, and design blocks to create scenery and buildings. This program was written for kids, so it's very easy to use.

The player chooses shapes, letters, numbers, people, animals and objects, then arranges them on-screen. Everything can be colored, objects can be duplicated as often as desired, and many of the characters and vehicles can be animated. A unique freeze option even lets the artist animate objects out of sequence. In other words, birds in a flock which would ordinarily look like a syncopated ballet, can be made to move independently, so that each bird bobs and nods individually.

Objects can move across the screen. This proves especially effective, for example, in a painted plains setting where a train chugs over the prairie.

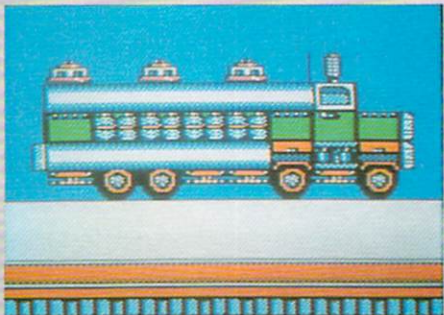

patterns. A mirror option lets the artist draw four ways at once. It is possible to reduce, enlarge, rotate, or combine illustrations.

By inputting commands chosen from a menu, young users learn how to program. The program thus encourages logical thought and careful planning, and gives a practical demonstration of how computers work. Although *Mr. Pixel's Programming Paint Set* lacks the finesse of *Designer's Pencil*, its use of pictorial icons makes it more approachable for young users.

Kid Pro Quo (Softsync, 162 Madison Avenue, New York, NY 10016) is an anthology program. Designed for ages eight to 14, it contains a word processor, drawing program, animation screen, and music composition program. It's meant to be an all-activity companion to write reports, stories, letters or homework, then il-

Rather than drawing directly on-screen with a light pen, *Designer's Pencil* develops artistic computer programs.

lustrate and animate the illustrations, and finally compose a melodic accompaniment.

Kid Pro Quo features a large library of pre-drawn images on disk. These can be enlarged or reduced, copied, and recolored. An on-screen tutorial takes the child through every step, while the manual backs it up with clear explanations.

Choosing the best art program is a matter of individual taste, talent and preference. Decide whether you want to use a joystick, keyboard, or light pen as your tool. A talented artist might do best with a full-featured package to get the largest choice of options and graphic aids. Less skilled drawing students may prefer to use the computer's muscles with one of the programming-style art programs. Ease of operation is especially important for beginners and children. If the user plans to integrate drawings into manuscripts, a combination program that permits word processing and picture creation would be best.

Regardless of the style of art program, just about everyone who owns a Commodore 64 should add one to his or her collection. They're fun to explore and mentally stimulating. Your own creative abilities may surprise you. **C**

Numerous programs contain banks of drawings on disk, along with glitzy pre-drawn backgrounds. By combining these, even an all-thumbs, hamhanded creator can create attractive scenes.

After you set the stage and construct the desired background, you choose the musical accompaniment from the disk's sound library. Finally, the Jazz Scats enter. The user individually programs each one with the joystick. When the scene is completed, the user plays it back in an original animated movie. (*Movie Musical Madness* is reviewed in this issue.)

Mr. Pixel's Cartoon Kit (Mindscape, 3444 Dundee Road, Northbrook, IL 60062) works on the same principle, but is more versatile. Youngsters program the on-screen cartoon characters to move around the scene. The system is almost identical with the routine that produces the paintings in *Mr. Pixel's Programming Paint Set*. At its simplest level, users choose pre-made characters and backgrounds. You can also redraw these characters pixel by pixel, to customize or completely remake them, then create frame animations.

Since *Mr. Pixel's Cartoon Kit* interacts with *Mr. Pixel's Programming Paint Set*, drawings made with the *Paint Set* can be used as backgrounds for the *Cartoon Kit*.

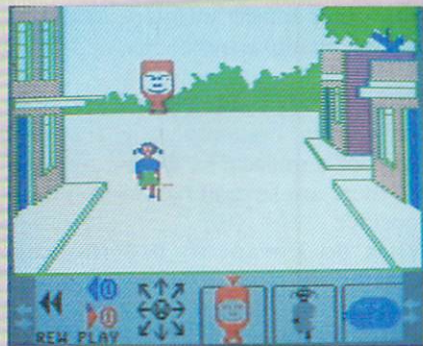

Pic.Builder (Weekly Reader, 245 Long Hill Road, Middletown, CT 06457) is a build-it-yourself picture kit. Instead of using a palette of paints, the artist has a palette of picture parts: bricks, rocks, designs, terrain, animals, water, and sky. These design chips combine in an infinite number of ways to create unlimited scenes.

There are five separate palettes: space, castle, farm, machine, house, landscape, border, and trucks. To get the artist off to a good start, each palette includes several prepared drawings.

But these aren't paintings to call up and passively admire. *Pic.Builder's* on-screen magic is more akin to paint by number. Each picture, when first shown on the screen, is nothing but 120 blocks of letters and numbers, indicating the picture-part that must be inserted. The user moves a cursor to a block, types in the appropriate letter and number, then taps the joystick button to print that design chip. Naturally, every picture can be infinitely altered, just by inserting different blocks.

Doing it yourself is the real fun with *Pic.Builder*. It's a highly original tool that lets even fumble-fingered aspiring artists create diverse scenes. **C**

Commodore 64 Music Keyboard Buyers' Guide

BY TOM BENFORD

When it comes to making music on the Commodore 64, a piano-style keyboard is indeed a good thing. However, when there are so many "good things" on the market, making the right choice is difficult. There's something for everyone in this buyer's guide, whether you're a "plinker" or a Beethoven. This article will help you make your choice.

All of the keyboards included here come with some form of "driver" software, with the exception of Sequential's Max. In most instances, this driver software is fairly limited in what it will do—allowing you to make music with the keyboard, period. All of these keyboards will work with other music software in the respective manufacturer's line.

What's right for you?

If you're contemplating the purchase of a musical keyboard for your 64, there are several factors you must consider.

What do I want to use the keyboard for? If your needs are purely recreational, and you don't intend to do any "heavy duty" composing or scoring, you may be quite content with one of the lower-priced models with less than 30 keys. If you have more serious applications in mind, you'll want more than 30 keys to give you some "moving room." You, and only you, know what your intended applications are.

How delicate is the keyboard? If you have small children in your household who will be using the keyboard, durability becomes a factor. Likewise, if you intend to use it in a professional environment, such as playing with a band, you'll want a keyboard that is well made and offers a high degree of durability.

How's the "action" (or "feel") of the keys? Once again, your needs and intended applications come into

*There's something
for everyone in this
buyer's guide, whether
you're a "plinker"
or a Beethoven.*

play. If you're just a livingroom "plinker," any of these keyboards will do nicely. But if you have serious performing or composing to do, you're more likely to favor a keyboard with full-sized keys and snappy action; one that closely duplicates the action of stand-alone keyboard instruments such as organs and electric pianos.

How deep are my pockets? Ultimately, you get what you pay for. The more expensive models generally have a better feel, the construction is better, they offer more keys for expanded range, and they're closer to "standard" instruments as far as durability goes. You don't have to spend a bundle to get a good keyboard, but then again, you shouldn't expect to get the cream of the crop for a mere pittance. Bear in mind that to get the most from the keyboard, you'll have to spend additional money on software or other accessories, perhaps an external amplifier. Unless you have unlimited funds, the cost factor is often a major one.

With those thoughts in mind, let's take a look at what keyboards are presently available and what features they offer.

MAX Computer Peripheral

The MAX MIDI Voice Expander Computer Peripheral from Sequential Circuits is a *tour de force* for creating computer music. It's a hybrid device that combines several outstanding features. The MAX is an independent six-voice music synthesizer. It has six-track digital recording capability, and is totally compatible with the 64 when coupled through a MIDI (Musical Instrument Digital Interface).

Although it's quite impressive by itself, by using a 64 to control the MAX, the resulting musical and recording capabilities are absolutely incredible. With the 64 as the master control device, it's possible to create new and unique sounds, download them into the MAX, and duplicate the sound of virtually any musical instrument or sound effect.

Sequential's software for linking the MAX with the 64 (known as *Soundware*) through a MIDI allows you to create six-voice compositions. Additionally, you can store this digital music data on disk for recall and replay at any time.

A really nice feature of the MAX is its multi-track digital recording capability. This permits you to "lay down" individual monophonic or polyphonic tracks to produce the sound of a full six-part ensemble, changing the instrument sounds as desired. MAX comes with 79 pieces of preset music, percussion and special effect sounds programmed into it, and allows you to load an additional 20 sounds for a total of 99. The MIDI will also allow the 64 and MAX combo to utilize a drum machine. Voila, the "one-man band" (or perhaps I should say orchestra) becomes a reality.

With a \$795 price tag plus the cost of the MIDI and *Soundware*, the MAX is obviously not intended for the low-end user. But if you have serious composing or performing in mind, and your wallet can stand the strain, this is the way to go. MAX and the 64 make an unbeatable combination.

Soundchaser 64

Passport Designs, well known for their MIDI hardware and software products, has released the Soundchaser 64 keyboard. A *Basic Music Synthesizer* software disk comes with the keyboard that allows you to start making music in short order.



The Soundchaser 64 keyboard features 49 full-sized keys, and the keyboard action is crisp and snappy. The keyboard connects to the 64 through the cartridge port with a cartridge-like connector.

The unit is constructed of quality-grade plastic, and its tan color complements the 64 nicely. The keyboard is lightweight for easy portability, and it certainly seems to be rugged enough to take "on-the-road" use and hold up well with reasonable care.

The *Basic Music Synthesis* software that accompanies the Soundchaser is that exactly—basic. While it allows selection of either mono or polyphonic modes and permits limited altering of the pre-set sounds, that's about all it does. This "bare-bones" driver software does not permit saving your sounds or songs to disk, but accessory software that will have this and other features should be available by the time you read this.

The documentation supplied with the keyboard is sparse, but it's scarcely missed since the software has an instructional mode that explains all. I particularly like this idea, since I'm a great one for misplacing user manuals.

Having a full four-octave keyboard at your disposal is a feature that many serious amateur or professional musicians will appreciate.

Melodian

The Melodian keyboard from Melodian, Inc., was obviously designed for the computer musician on the go. It features a snap-on protective cover for the keys that doubles as a music stand when the keyboard is in use. It has a handy pop-out carrying handle and comes complete with *Concertmaster* software and excellent documentation.

The 40-key keyboard has a nice feel to it, closely resembling an electronic organ. This is no surprise, since the

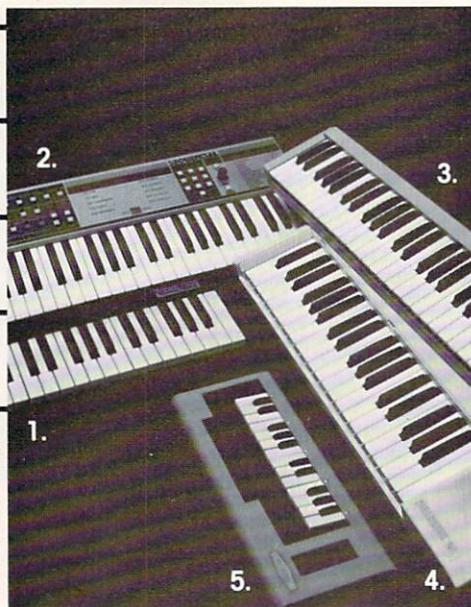

basic keyboard is manufactured by Bontempi of Italy, a major producer of portable organs. Forty keys should be more than sufficient for all but the most demanding applications.

Unlike the driver software supplied with the other keyboards, the *Concertmaster* software supplied with the Melodian keyboard is the most complete software package of those we consider here. The only major feature it lacks is the capability to print your compositions on a line printer. The supplied *Concertmaster* driver software does allow storage and retrieval of your pre-set sounds and compositions to disk, altering of sounds, and a host of other features.

The Melodian documentation is superb, providing all the information you'll need to enjoy the keyboard and utilize the software to the fullest. An excellent music tutorial is also included which is well written and comprehensive.

The keyboard connects to the 64 through both the user and joystick ports, using a tandem connector scheme. It's a well-made unit constructed of high-impact plastic that should hold up very well.

The Melodian is a good choice for the beginner as well as the pro musician, and its sound quality, play action and design make it well suited for most applications.

MusicMate

The MusicMate from Sequential Circuits is a compact 32-key (2-1/2 octave) unit that has surprisingly nice play action for an under-\$100 keyboard. It plugs into the joystick port and comes with polyphonic driver

software, called #970 *MusicWare*.

The keyboard is sturdily constructed of plastic. Its light weight and compact size make it easy to use and transport. The piano-style keys are just a tad smaller than standard size, but I encountered no problems whatsoever using the keyboard or fingering chords. The play action and overall feel of the keyboard is excellent.

The #970 *MusicWare* driver software allows you to create music in polyphonic mode, hold it in computer memory, and play it back. No provision is included for saving your compositions or pre-set sounds to disk with the basic #970 *MusicWare* included, but other *MusicWare* titles in Sequential's line do have this capability.

The MusicMate is a good choice for beginning through relatively advanced computer musicians, but serious professionals might find the 32-key range a bit limiting. For the majority of musical applications, however, it will prove to be more than adequate.

Incredible Musical Keyboard

Sight & Sound Music Software brings us the Incredible Musical Keyboard. This novel unit is not a keyboard in the true sense of the word, but an overlay that sits on top of the 64's qwerty keyboard. Though a rather bizarre design, it does make creating music on the 64 a bit easier. Since it sits on top of the 64, it has a tendency to move around a bit, but I found that a couple of strips of masking tape to secure its position work wonders.

The Incredible Musical Keyboard is constructed of plastic, but owing to its design, is *very* delicate. The "keys" are attached to the frame by thin strips, and they won't survive rough handling.

The "keys" are small, and play action is nonexistent, since you're

merely depress
ing the 64's keys by
an added lever. The key-
board is functional at best, but as a
novel and fun means for creating music
on the computer, it succeeds nicely.

The driver software supplied with
the keyboard is the barest of the
"bare-bones" variety, but Sight &
Sound has other music programs in
their line that will work also.

Colortone

Waveform, Inc., best known for
their superb *MusiCalc* music soft-
ware, has unleashed the Colortone
keyboard. Waveform calls it a key-
board, but this is indeed a misnomer.
The Colortone is more of a touch-sen-
sor tablet, since it doesn't have any
real keys on it. There is an imprinted
area that looks like a keyboard, but no

real keys.

Even though this is a unique and
unorthodox configuration, the Color-
tone is loads of fun. One of the more
novel features of the unit is a "Touch
Harp." This is a multi-colored band
that inputs music when you simply
run your fingers along it.

With the Colortone keyboard and
accompanying software, *anyone* can
sound like a pro, even if they have a
"tin" ear. The secret is the software.
The program effectively *locks out*
sour or wrong notes, so when you run
your fingers up and down the "keys,"
only those notes which are harmoni-
cally correct will be sounded. A var-
ied selection of musical themes is pro-
vided on the disk, and you can reap
musical rewards with the Colortone
immediately upon connecting it to
the joystick port and booting the disk.

While the Colortone can be used
with Waveform's *MusiCalc* software
line, I doubt that anyone would want
to. That software is for creating seri-
ous musical sequences, while the Col-
ortone is purely for fun.

So there you have our keyboard
roundup. For quick reference and
comparison of features, I've included
a chart of the keyboards reviewed.
For more information on any of these
keyboards, contact the manufacturers
directly.

No matter which of these key-
boards you choose, the 64 with its
SID chip is the real superstar. The key-
boards and software merely make ac-
cessing the SID's capabilities easier
and faster. The important thing is to
have fun making music. These key-
boards will help. After all, that's what
it's all about. C

Keyboard Buyer's Guide

Numbers refer to photos on these pages

KEYBOARD NAME	MANUFACTURER	# of KEYS	INPUT (C-64)	SPECIAL FEATURES	PRICE
1 MUSICMATE & 2 MAX SYNTHESIZER	SEQUENTIAL, INC. 3051 N. First Street San Jose, CA 95134 (408) 946-5240	32	JOYSTICK PORT	—	\$ 99.00
3 INCREDIBLE MUSICAL KEYBOARD	SIGHT & SOUND 3200 S. 166th St. New Berlin, WI 53151 (414) 784-5850	24	C-64 KEYBOARD	—	\$ 29.95
4 MELODIAN	MELODIAN, INC. 115 Broadway New York, NY 10006 (212) 406-5163	40	USER & JOY PORT	—	\$199.95
5 SOUNDCHASER 64	PASSPORT DESIGNS 625 Miramontes St. Suite 103 Half Moon Bay, CA 94019 (415) 726-0280	49	CARTRIDGE PORT	—	\$199.00
6 COLORTONE	WAVEFORM, INC. 1912 Bonita Way Berkeley, CA 94704 (415) 841-9866	25	JOYSTICK PORT	TOUCH HARP	\$ 79.95



WHY THE COMMODORE 64 ISN'T IN A CLASS BY ITSELF.

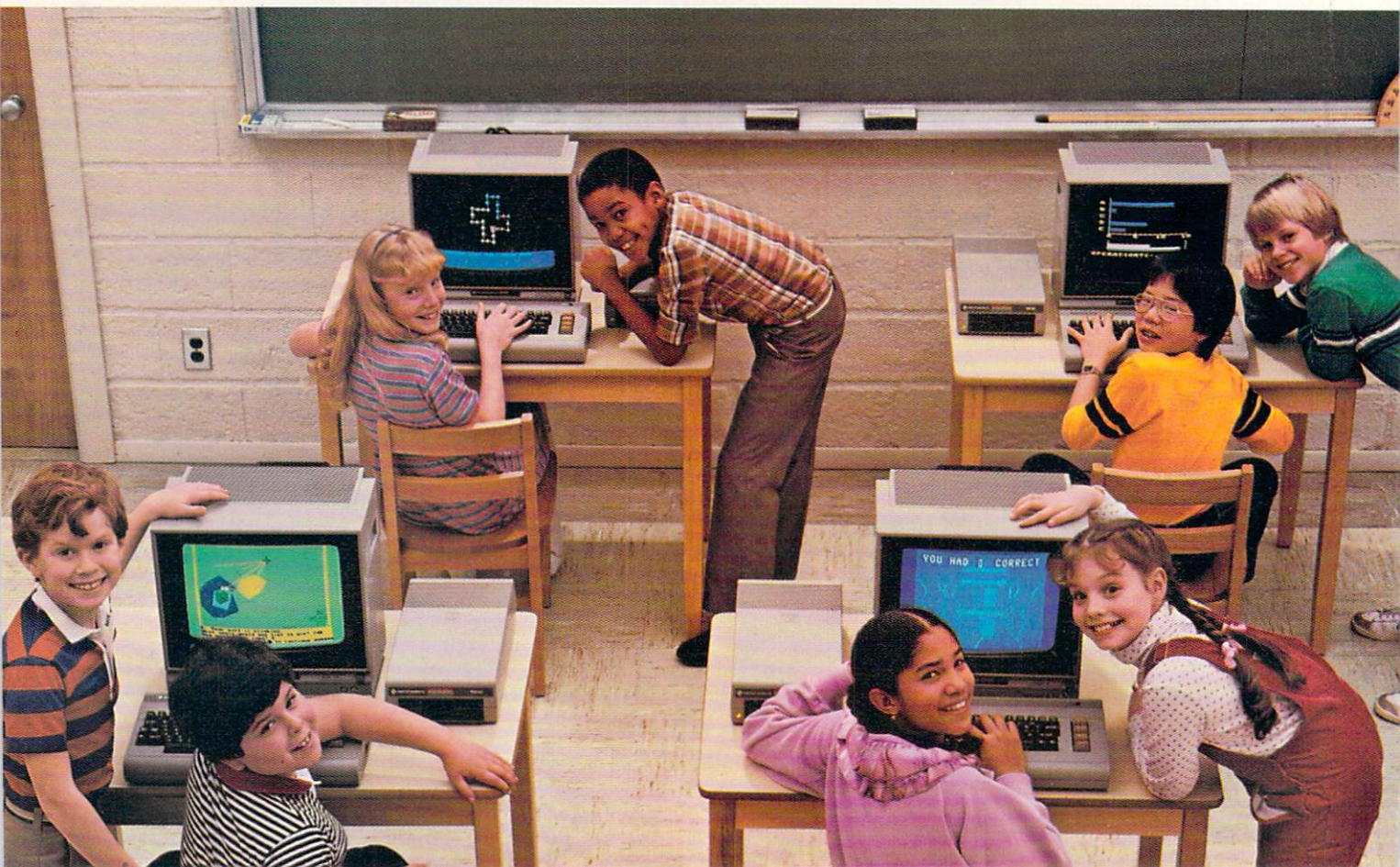

At Commodore, we think it's easier for school children to learn about a computer by using it rather than by waiting to use it.

So, we sell the Commodore 64™ at about half the cost of comparable computers.

With the money you save on the Commodore 64, you can afford the things you'll really need: more Commodore 64's.

In fact you can create a powerful but economical "Local Network" with 8 computers sharing one disc drive.

The Commodore 64 features: 64K memory, 66 key typewriter-style keyboard, 16 color high resolution graphics, 9 octave music synthesizer and 3-dimensional sprites.

And the same commitment we make to hardware, we're making to software. We have highly rated Logo and PILOT programs. Much of the well recognized MECC™ courseware and the Edufun™ Series from Milliken will soon be available. There are hundreds of other programs, including a wealth of public domain software for the Commodore 64. Our newest additions are 30 early learning programs from Midwest Software.

So you see, the all purpose Commodore 64 really is in a class by itself.

For further information on the Commodore 64 and our 250 Educational Resource Centers, contact your nearest Commodore Education Dealer.



 **commodore**
COMPUTERS

Donald Duck's Playground

Computer: Commodore 64

Publisher: Sierra

P.O. Box 485

Coarsegold, CA 93614

Medium: Disk

Donald wants to build a playground for Huey, Dewey and Louie, but he needs capital. To come up with the cash, Donald (with a little help from the player) works at a produce stand, toy store, airline cargo depot, and railroad.

Donald Duck's Playground is about money. It teaches youngsters (ages 7 to 11) how to count cash, make change, pay for purchases, and keep track of their assets. Better yet, it hints at the real-world relationship between work and possessions.

Donald works long and hard at McDuck Airlines, where he sorts packages into cargo carts. The screen displays a plane landing, then a train of cargo cars driving to where a conveyor belt of packages waits to be loaded. Donald must throw each box into the correct tram, matching the three-letter destination codes on the packages to those on the tram cars. At upper skill levels, the airport codes on the boxes have more letters. Donald is paid for each package correctly loaded.

Donald's job at the fruit and vegetable market is similar. Here he sorts produce into bins. Melons, pumpkins, fruit and veggies are tossed from the back of a produce truck for Donald to catch and drop into their proper bins. If he misses, the fruit falls to the conveyor belt with a colorful splat.

Like most kids, Donald likes the toy store best. There he stows new merchandise on shelves. Each new toy first appears on a loading dock, and the gamer has to match the item on the storage shelf. Moving a ladder to that spot, Donald picks up the new toy, carries it up the ladder, and places it beside its match. Then he must move the ladder to a new spot, and run for another toy to be shelved.

Unfortunately, when the Amquack Special rumbles past, toys slide off the shelves. Donald has to keep an eye on

Donald Duck's Playground is about money. It teaches youngsters how to count cash, make change, pay for purchases, and keep track of their assets.

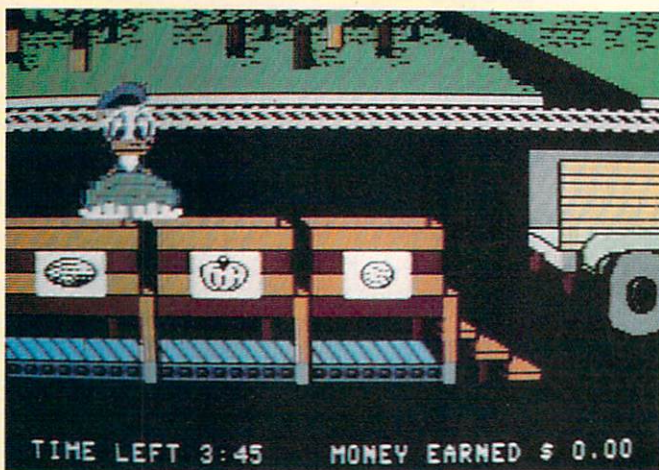
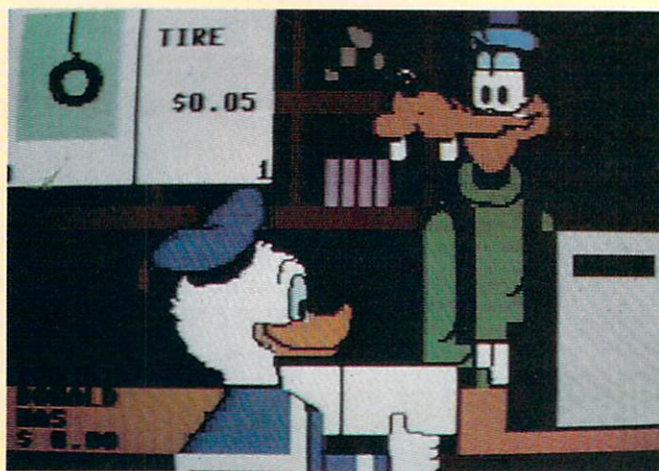

the train schedule, and close the door to the toy cabinet before the train arrives to keep the toys from crashing to the ground. Donald is paid for each toy properly shelved, but if any fall and break, their value is deducted from his salary. At upper skill levels, there are more toys and the train passes more often.

The best place to work to earn duck bucks is the Amquack Railroad, where Donald is the dispatcher and switchman. The miniature railroad layout is seen from overhead. The train picks up packages for delivery up and down the line, and Donald must open or close junction switches so the train is routed to the correct towns.

All work and no play, however, makes Donald a dull duck, so after he's earned his money, it's time for fun. Now Donald can shop for the playground. After he makes his choice, the scene switches to a cash register screen. By moving a cursor to

select the bills and coins needed to cover the purchases and making change as necessary, Donald buys his new equipment. At upper skill levels, the playground equipment is more expensive.

Donald's selections are automatically delivered to the playground at the end of Main Street. The duck can visit the park anytime by walking down the street and across the tracks. (Donald carefully looks both ways before crossing, of course.)

The playground sequence features delightful animations of one of Donald's nephews. Controlled by the joystick jockey, he swings, climbs ladders and nets, slides, bounces on the toy horse, and has a grand old time.

Donald Duck's Playground is undoubtedly one of the best educational games ever devised. The program, specifically designed to teach kids to count money and make change, contains a wealth of entertainment possi-

Movie Musical Madness

Computer: Commodore 64

Publisher: CBS Software
One Fawcett Place
Greenwich, CT 06836

Medium: Disk

Those Jazz Scats are at it again, and this time they're off to Tinsel Town. They've just completed their first major Hollywood production called *Movie Musical Madness*.

This fun-filled program includes a record which features—you guessed it—the Jazz Scats, in addition to a well illustrated documentation manual. The record is all you really need to use the program, but the manual and separate 64 addendum sheet supply supplemental information.

Movie Musical Madness makes you the producer, writer, composer and director on your own Hollywood sound stage. This program is so rife with features that it's difficult to know where to begin.

A joystick is used to set the stage, place the props, select the actors, pick out a musical score, and "direct" the action. For actors, you have any of the three Jazz Scats—Swivel Hips, Wahoo or Mr. Bassman—"under contract" and at your disposal.

Talk about big budget productions and powerful assets. In *Movie Musical Madness*, you have almost enough power and creative freedom to make Steven Spielberg green with envy. Your movie can contain up to 16 scenes and you can change sets for each scene or carry over the same props from one scene to the next.

In Movie Musical Madness, you have almost enough power and creative freedom to make Steven Spielberg green with envy.



Let's not underestimate "prop power." Your prop department is a veritable Fort Knox of goodies containing all sorts of stationary, animated, and moving props. You name it and, chances are, the prop department will have it—street lights, fire hydrants, castles, skyscrapers, space ships, a piano, neon signs, fences, houses, and a goofy Keystone cop. You can include up to 49 props for a total of 784 props in a 16-scene production.

Being the film-production magnate that you are, you have absolute control of *everything* in your production, and that includes musical score. Choose from numerous "canned" sound tracks: anything from a sinister score for heavy mystery to bouncy be-bop for boogie-ing.

Upon loading *Movie Musical Mad-*

ness, select which Jazz Scat is to star in your first scene (fortunately without the hassle of negotiating a contract). Simply select your star with the joystick, then construct the set. A row of stage lights at the top of the screen holds your prop inventory, and any prop may be selected, positioned or repeated up to 49 times per scene. A row of stage lights at the bottom of the screen contains your soundtrack library.

Once you've decided on the set design and musical score, you're ready for your first "take." The function keys on the 64 are used to summon your star from the dressing room, and you're ready for "Action!" The joystick maneuvers the actor or actress, and the audible sound track makes choreographing the movements a snap. A visible horizon line on the screen helps position the props and gauge the movement of your star. You can even have your on-screen celebrity pass in back of props.

Let's suppose you aren't exactly ecstatic over your star's performance. No problem. You can view the "rushes" of each scene and do as many retakes as needed. You can even trash the whole production and start over. Retake any scene, because don't forget—it's your production.

You can also store your finished movies to disk to create a film archive. This way, call up some of your favorite productions and enjoy them whenever you like.

Movie Musical Madness is my personal choice for an Oscar. And what's more, it's a great program for kids of any age, including moms, dads and grandparents as well. It's wonderful fun that provides plenty of exercise for your creativity and imagination. **C**

bilities. The "employments" are all games in standard arcade molds. When the duck is catching fruit, sorting cargo, stashing toys, or operating the railroad, the joystick-wielder is perfecting hand-eye coordination, as well as developing spatial relationship, matching and logic skills.

Each of the four money-earning games is exquisitely drawn; a few years ago, any one of them might have stood alone as a video game. The railroad game is especially attractive.

Anyone who ever thrilled to a model railroad set should like throwing the switches to route the little train to the target cities. The cash register screen and wage window do exactly what they are meant to: they depict different denominations of money, help kids get used to counting coins and bills, and teach them to pay for purchases and count their change.

But it's the graphics that raise *Donald Duck's Playground* above most other educational games.

Donald and his nephews, and the other cartoon characters that mind the stores, look exactly as Disney might have intended. Finally, the last sequence is a terrific payoff for gamers who've mastered the four employments and earned money for the park's equipment. Gamers will enjoy moving the happy little creature around the equipment: swinging, climbing, sliding and having a ducky time in the new playground that Donald built. **C**

Addition Magician and Moptown Parade

Computer: Commodore 64
Publisher: The Learning Company
545 Middlefield Road
Menlo Park, CA 94025

Medium: Disk

Addition Magician is a game designed to help children ages six to ten practice addition. Not just another boring drill-and-practice arithmetic program, it's an entertaining puzzle-game where flexible problem-solving is as important as sum memorization. The basic game is simple: A game board containing nine one-digit numbers appears on the screen, with a target sum underneath. The player builds "magic walls" to divide the square into groups of numbers that add up to the target sum. For example, for the game board and the target sum shown here,

3	1	7
5	4	4
4	2	2
8		

the walls would need to divide the board like this:

3	1	7
5	4	4
4	2	2
8		

The pre-game menu screen allows you to choose the target sum (anything from six to 18, or ALL, which randomly chooses a sum for each game). The menu also offers options for setting time limits (Slow, Medium, Fast or None), number of turns (two to 20), and number of players (one or two). In the two-player version, two identical squares appear side by side.

Commodore kids are fortunate that



These games are carefully designed to motivate as they educate. From a kid's point of view, that means they're fun to play.

their version uses the friendly joystick versus the keyboard, but discriminating arcadians may be disappointed with the responsiveness of the joystick in two-player mode. When two players compete, the action is jerky, and sometimes it takes several button presses before the computer responds. Nevertheless, most gamers I know would choose a joystick over keyboard control. Don't give up the keyboard altogether, though—the program is set up so that you have to use it to select menu options and set parameters.

If a player successfully finishes every board in a round, he or she is awarded a small graphic prize and a brief musical fanfare. After four prizes, the screen shows the Wizard's treasure, four more wins bring a shot of the Wiz himself. These rewards, which motivate youngsters to keep playing, won't wow most adults. But don't write this game off, because when the timer is set on fast and the sum option is set on ALL, it's a fast-paced game that requires quick thinking and a touch of joystick dexterity. And there is no guarantee that you'll even win against your child!

Moptown Parade

Moptown Parade is another game designed to develop logic skills rather than memory. It's really seven menu-

selectable games in one, all built around a set of characters called moppets. There are 16 moppets in Moptown, and they're all different. Half are short, half are tall, half are fat, half are thin, half are blue, half are red, half are big-footed Bibbits, and half are curly-tailed Gribbits. These characters don't do much except follow rules, and those rules form the basis for the Moptown games. The easiest game, "Make My Twin," shows two boxes on the screen. One contains a Moppet and the other sits empty, waiting to be occupied. To find out about the occupant of that box, the program asks four questions in sequence. The player responds to those questions with single-letter key presses:

TALL OR SHORT? (T OR S)

FAT OR THIN? (F OR T)

RED OR BLUE? (R OR B)

BIBBIT OR GRIBBIT? (B OR G)

If all four answers are correct, a twin for the first moppet appears in the box. If there's a mistake somewhere, the program gives generous hints and waits patiently for corrections.

The next game, "Who's Different?" asks the child to decide which of four moppets is different and why. "What's the Same?" shows four mop-

pets in a house and asks the player which attribute all four have in common. "Make My Opposite" is similar to "Make my Twin" with the rules reversed.

The last three games are more complex. "Who Comes Next?" shows a line of four moppets followed by a big question mark. In the tradition of classic IQ tests, this one asks the child to discover the pattern in the arrangement of moppets (A B A B A B, A B B A B B, or A A B A A B) and describe the next one in the sequence. "Mop-town Parade" is another moppet lineup, but this time the child must determine all but the first, following a rule chosen at the beginning. According to the rule, each moppet in the parade must be different from its predecessor in one or more ways.

The Moptown "Clubhouse" uses one or more rules to determine who can belong, and it's up to the child to figure out who can join and what rule(s) are used to determine membership. The combination of trial-and-error and logic used in this game is reminiscent of Mastermind, the popular parlor game.

All of the Moptown games are educationally sound and carefully designed. The major drawback of the games is that they all depend on a certain amount of keyboard literacy on the child's part. Many children find it frustrating to search for a "T" or a "G" on the keyboard.

Moptown Parade and *Addition Magician* have several common characteristics. They both use sound and graphics effectively, but neither pushes the Commodore hardware to the limit. However, educational and entertainment value are more important than technical wizardry, and these programs deliver both. They come with thorough, easy-to-read manuals that clearly explain the how-to's and the educational what-for's. The booklets even have several sound suggestions for non-computer activities that relate to these programs. But you may never open the manuals, because the disks contain on-screen help that should be enough for anyone, young or old, who can read.

The games are carefully designed to motivate as they educate. From a kid's point of view, that means they're fun to play. **C**

Big Bird's Funhouse

Computer: Commodore 64

Publisher: CBS Software
One Fawcett Place
Greenwich, CT 06836

Medium: Disk

Big Bird's Funhouse is for youngsters ages three through six. It was developed by the very talented crew of Children's Television Workshop, and features all of the favorite Sesame Street characters.

Included is a handy EasyKey keyboard overlay which facilitates using the program for those little fingers. This overlay effectively prevents depressing the wrong key. It's gaily decorated with the likenesses of Cookie Monster, Telly Monster, Bert, The Count, Snuffle-Upagas, Grover, Oscar the Grouch and Ernie. Of course, Big Bird is included, but more as a moderator than a participant. Bird does provide some highly-entertaining dance routines in between play sessions, however.

A "How-To-Play" card containing concise loading and playing instructions is also included. The card is made of laminated plastic, so it's durable enough to stand up to handling by energetic youngsters.

The documentation is up to the usual high standards I've come to expect from CBS Software. It is profusely illustrated with colorful pictures of Sesame Street favorites. The program manual contains helpful suggestions for parents in guiding their child during play.

The animation, color, sound, and musical effects are all superb. Thanks to the EasyKey overlay, play action is also outstanding, even for the youngest of gamesters. Additionally, the game may be paused and restarted as desired, and the play level may also be changed at any time.

The objective of *Big Bird's Funhouse* is to develop early learning skills: visual discrimination and matching, auditory discrimination and matching, memorization, sequencing, and counting.

It has five play levels, each easily se-

Big Bird's Funhouse is a delightful program that is particularly suited to the pre-school youngster.



lected. On the first three play levels, the child chooses (or "invites") the Muppet characters who are to be in the game. On levels four and five, however, the computer selects the characters. A maximum of three Muppets are permitted on the screen at any time.

Once the characters are selected, the Sesame Street personalities scurry off to hide. The child's task is to remember who is hiding where. By pressing the corresponding character key, the child uncovers the Muppet playmates. Each correct guess is rewarded with a musical salute, and correctly guessing all three characters brings on a lively dance routine.

The feathered TV superstar also comes out and shakes his head for an incorrect guess. A second incorrect guess evokes a musical clue (each character has his own theme music) and a third incorrect guess prompts the hiding character to "pop-up" for a second to further help the youngster.

Big Bird's Funhouse is a delightful program that is particularly suited to the pre-school youngster. Highly entertaining and easy to play, it seems to be an effective tool for developing early learning skills. It's a fun-filled program that will start your youngster off on his or her educational journey, and is highly recommended. **C**

Swiss Family Robinson and Below the Root

Computer: Commodore 64
Publisher: Windham Classics
 Spinnaker Software
 One Kendall Square
 Cambridge, MA 02139
Medium: Disk

Swiss Family Robinson, based on the 18th-century book by Johann Wyss, is a test of ingenuity. The family's misfortunes only begin after their ship is wrecked and they are left stranded. The illustrated text adventure provides aid for the stranded family: the makings of a boat, a shipload of useful tools, weapons, and even food to last until they find new. There's plenty of time to gather up all these goodies, figure out how to construct the boat, and fit everything aboard. But once the rescue boat is launched, the leisurely pace ends. First, the shipwrecked family has to contend with an attacking shark. Later, when the tiny craft finally runs aground, safety is still not assured; some landfalls are so inhospitable that the weary family must put to sea again to find a better port.

The real fun starts when the Robinsons finally locate their new home. The island is large, with terrain that ranges from mud flats and quicksand traps, to caves, forests, beaches and lagoons. There are over 200 locations to explore, all attractively illustrated.

Among the survival tools taken from the ship is the book *The World Traveler's Guide to Nature*. When the player consults this tome about items found on the island, it will give oblique clues on how they can be used. Even more helpful is the self-completing map. By carrying it along, all locations are automatically charted. This way, the explorer doesn't get lost.

The player uses the keyboard to interact with the story. A help key summons a screenful of possible commands and often family members

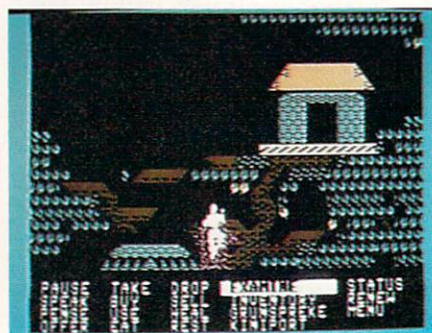
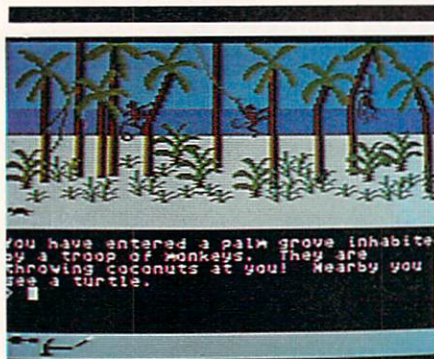

Two classic tales from children's literature form the background worlds in these adventures geared to players ages ten through adult.

themselves volunteer information. As a general rule, success demands careful thinking and creative use of the resources at hand. But this might not be enough for some younger gamers, who may need a more substantial hint list than the one in the manual.

Swiss Family Robinson is extremely well suited to be a novel-turned-game. It's not necessary to have read the book to enjoy the adventure, but *Swiss Family Robinson* lovers will appreciate how faithfully the designers adhered to the original. As in the classic, the family survives only by utilizing the resources of the island. The computer brings to life the struggle to locate and use these resources.

Below the Root

Below the Root is based on the *Green-Sky* trilogy written by Zilpha Keatley Snyder. *Green-Sky* is a verdant world filled with treehouse-living inhabitants. The gamer assumes the role of one of these tree-dwellers and seeks clues to save *Green-Sky* from destruction.

The gamer chooses one of five *Green-Sky* inhabitants. Some have more stamina; others have higher spirit limits. Spirit talents include pensing (or mind-reading), healing, Grunsprekeing (influencing the growth of trees), and Kiniporting (teleporting), arts which must be mastered for success.

The action adventure begins where the books ended. The gamer uses a joystick to move an animated figure

through the tree-top towns, private homes, stores, temples and meeting halls, climbing up and down on vines and ladders. By reading minds, the gamer determines who is good and evil. Speaking with them often gains gifts of food, shelter and money tokens, as well as hints. The adventurer can find or purchase other helpful aids, including a tool for cutting through obstacles, vine ropes, even a flying suit that lets the gamer glide through the branches.

There's a delightful sense of alienness to *Below the Root*. The tree society is complex and vast, with over 400 locations. Teleporting, mindreading, and gliding through the branches adds a dimension of other-worldliness.

The package comes with a map of the landscape. Walking, running, jumping, crawling and all other actions are controlled by joystick. Gamers go to an option menu to mindread, teleport, buy, sell, take, speak, use items, eat, or check their own status.

It's not absolutely necessary to read the *Green-Sky* books to play *Below the Root*, but it will enhance gamers' enjoyment. In fact, the game would probably benefit by a few pages of introductory text about the world and its characters.

Whether or not it is familiar, *Below the Root* does have a great deal of charm, especially for the younger players. The attractive illustrations and ease of joystick operations make this one world that gamers will want to learn more about.

Tuk Goes to Town

Computer: Commodore 64

Publisher: Mindscape

3444 Dundee Road
Northbrook, IL 60062

Medium: Disk

T*uk Goes to Town* is one of a series of Tink!Tonk! programs designed and written by award-winning children's author and illustrator Mercer Mayer, whose *Little Monster* books have delighted children for years. These programs, tailored by a major educational publisher for children between ages four and eight, are visually captivating, educationally sound, and just plain fun.

The Tink!Tonk! programs are like interactive storybooks with built-in games. Each program in the series is unique, but they all take place in TinkTonk Land, the home of the TinkTonks. The booklet that comes with *Tuk Goes to Town* introduces the major characters of TinkTonk Land: Tink, their trusty leader; Tonk, his best friend; Tuk, the gardener; and others. This particular program tells the story of Tuk's trip to town and back home. But *Tuk Goes to Town* is not just another overpriced electronic page-turner. It demands involvement from the opening screen when it announces:

Tuk wants to do something! Shall he:

1. GO TO TOWN
2. PLAY A GAME

PRESS 1 OR 2

Either way, Tuk has plenty of chances to play games. Choice number 1 ties the games together with a storyline, while choice 2 skips the story and presents a menu of game choices instead. When a first-time player chooses 1, the disk whirs and the computer introduces Tuk.

THIS IS TUK.

HE LIVES IN TINKTONK LAND.

TUK WANTS TO GO TO TOWN.
HELP HIM CHOOSE HOW TO TRAVEL.

Tuk Goes to Town is not just another overpriced electronic page-turner. It demands involvement.

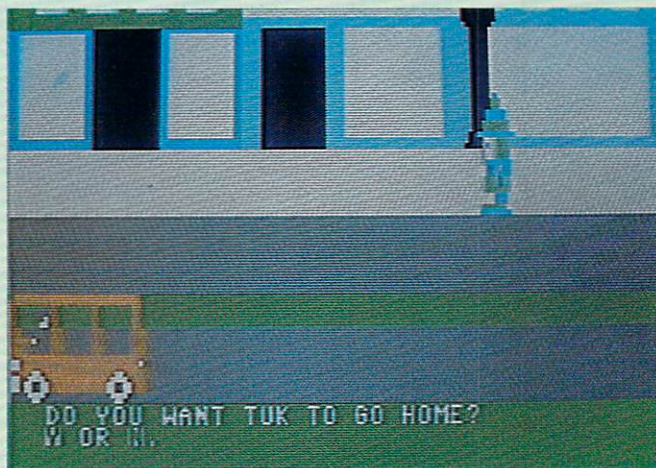

PRESS SPACEBAR TO SEE EIGHT CHOICES.

The disk whirs again and the screen shows a car numbered 1, a truck numbered 2, a bus numbered 3, and another message.

PRESS A NUMBER OR SPACEBAR FOR MORE.

More, in this case, means train, motorcycle, tugboat, speedboat, and raft.

Whichever the child chooses, she's immediately confronted with more choices: Should Tuk go to town via the farm, the fair, the forest and/or the seashore (he can pass two on each trip)? When all those decisions have been made, Tuk (finally) heads downtown in a delightful animated sequence. As he passes through hand-picked landscapes (with details that change with each trip to town), a message at the bottom of the screen reminds our young player that she's in

charge:

STOP = S GO = G
PLAY A GAME = P

The game depends on the environment. The farm game, designed to develop spelling and vocabulary skills, involves using the keyboard to unscramble the names of pictured farm animals, or, in a more advanced version, farm words without pictures. Similarly, the seashore game presents scrambled seashore words which must be unscrambled (or words with missing vowels which must be completed) to help Tuk win a boat race. At the fair, there's a simple duck shoot where the gunsight is controlled by the J and K keys and RETURN pulls the trigger—but only when the sight is set on a duck with a shape that matches the shapes moving across the bottom of the screen. The forest game is a concentration/memory game; the

Continued on page 124

Stickybear

Computer: Commodore 64
Publisher: Weekly Reader Software
 245 Long Hill Road
 Middletown, CT 06457
Medium: Disk

Finally, my son Jordan can legitimately sign up on the family roster for unrestricted, exclusive computer time. By unrestricted, I mean the freedom to stay at the computer until HE is ready to turn it off. By exclusive, I mean ALONE. As in by himself. At age four? Enter Weekly Reader's *Stickybear* series: *Stickybear ABC*, *Stickybear Numbers* and *Stickybear Basketbounce*.

Stickybear programs all load with the same command—LOAD "PRG",8,1—which took Jordan all of two practice sessions to remember. *Stickybear* programs also utilize the refreshing simplicity of "key-logic." In other words, if the child wants to see the letter "B," he presses the letter "B." If he wants to see the number eight, he presses the number eight.

Stickybear programs are "child-proof." Just as a parent locks a cabinet to protect a child from ingesting poison, so, too, do the *Stickybear* programs protect the child from accidentally hitting a key that sends the program off into computer never-never land.

For example, in *Stickybear ABC*, only the alphabet keys respond. The number keys and most of the other non-alphabet keys are locked like the bathroom cabinet. Only the INST/DEL key has a function: specifically, to take the child back to the opening screen where he can choose to play another of the three ABC games on the disk. Key F1 plays the ABC game, F3, the Match game, and F5 the Order game.

Stickybear ABC offers two different animated pictures in bright, sunny colors for each letter of the alphabet. Hit the letter "B," and you'll see a picture of a plump, friendly-looking bee buzzing around Stickybear's head. Later, if you press "B" again, you'll get the picture of a big blue and yellow ball bouncing around the screen.

Similarly, the letter "A" conjures up

Besides being educational, fun, and extremely easy to use and explore, all of the Stickybear programs are an absolute delight to the senses.

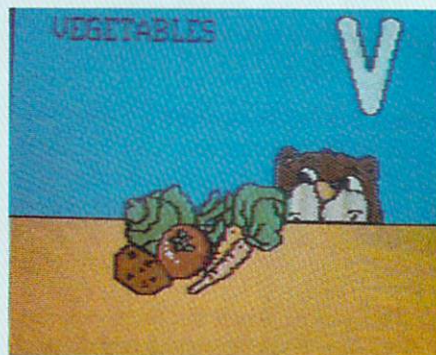

either an airplane soaring through fluffy white clouds, or a ripe red apple that falls from a tree, bounces on the ground and comes to rest next to the word apple.

In the Match game, the entire alphabet appears on-screen—but with one letter in a different color. The child must then press the matching letter on the keyboard to see the related pictures.

The third game in *Stickybear ABC* is called Order. The child must press the letters of the alphabet, one by one, in the correct sequence. If the "wrong" letter is pressed—"wrong" meaning, for example, that "G" does not come after "C"—the program "chirps" and shows the child the alphabet screen with the correct letter highlighted.

The *Stickybear Numbers* program works much the same way as *Stickybear ABC*, only simpler. From the title screen, a child begins by pressing either a number key or the spacebar. If the child wants to start with the number six, he presses the number six. If he chooses to start by hitting the spacebar, the first screen will show the number one. And like *Stickybear ABC*, the program is foolproof. A child simply cannot hit a "wrong"

key. Throughout the program, the number keys and the spacebar are the only keys that respond.

At the opening screen, Jordan starts by hitting the spacebar. A moment later a beautiful undersea world appears with a single golden fish swimming about. At the lower right hand corner is the number one.

"Good-bye fishy!" Jordan shouts as he presses the number six. Immediately, a new screen loads. This time, a hungry, wide-eyed Stickybear sits at a table while, one by one, an assembly line of ice cream sodas appear. When he has consumed the first (which takes him all of one big sloppy sounding slurp), the empty soda glass moves over to make way for the next cherry-topped treat. Soon, there are six empty dessert glasses lined up in front of a very satiated Stickybear.

Randomly testing the program, Jordan presses the spacebar. Like magic, one of the glasses disappears, and the number six in the corner of the screen transforms into the number five. He presses the spacebar again, and another glass bites the dust, while the number changes to four. Jordan giggles with a mixture of delight and growing sense of power, and keeps

Continued next page

SPECIAL SECTION: SOFTWARE FOR CHILDREN

pressing the spacebar, making the glasses vanish, one at a time, until there are none. When the table is emptied, the number in the corner is zero.

After running through this disappearing routine a few times, with various numbers of various objects, Jordan suddenly made the incredible connection that five robots, take away one robot, is four robots; nine airplanes, take away one airplane, is eight airplanes; and three penguins, take away one penguin, is two penguins. Elementary, my dear Watson, but profound to a pre-schooler.

The number of different pictures in this program is impressive. At one point, Jordan pressed the number seven nine times in a row. And every time he got seven new animated objects.

The *Stickybear Basketbounce* instruction sheet states that this is a game for the entire family. I beg to differ. There are 16 increasingly more challenging levels. Jordan has already reached the eighth level. Joshua, age

nine, and exceedingly well versed in the in's and out's of video strategy and stamina, is trying to break his level 13 record. On the other hand, neither my husband nor I have managed to get beyond the fifth screen.

The game is deceptively simple. With your joystick, maneuver Stickybear around the screen, while objects fall from above. Win points as you catch the colorful, twirling, bouncing, falling objects—which include balls, donuts, bricks, and stars. At the same time, avoid objects that come rolling across the floor by making Stickybear jump over them. If an object hits Stickybear, he falls down or trips, and you lose a basket.

It takes good hand-eye coordination, quick reflexes and practice to survive. Get bonked, bumped or tripped one too many times and you lose all your baskets. Then a monkey driving a bright red bulldozer drives in and gently pushes your Stickybear off the screen.

At the end of the game, you are shown the score roster. If your score

puts you in the top ten for the disk, add your name to the winner's list for posterity. Every time someone adds their name and winning score, the last name (and lowest score) at the bottom drops off. (Personally, I think it's rude for a child to continually bump off his mother's name.)

Besides being educational, fun, and extremely easy to use and explore, all of the Stickybear programs are an absolute delight to the senses. The graphics are faultlessly superb, the colors are vibrant and rich, and the sound effects range from attention-getting to melodious. And Stickybear comes bearing a gift as well. Inside each package is a big colorful Stickybear poster.

Stickybear is simply a big, innocent, roly-poly, make-believe teddy. But he's a real natural with the kids. So, if your youngster, like mine, can't read and doesn't care what a syntax error is, but shows an insatiable natural propensity for the family computer, then introduce him or her to *Stickybear*. C

C-64 & C-128* OWNERS:

Stop playing "Hide-and-Seek" with your Disk software! Let your Commodore 64™ "memory" do all the work for you with **MASTERDISK**®. Easy Menu-Guides make everyone a "pro" in 1 day! Here's a small "PEEK" at SOME of the FULLY-INTEGRATED POWER of PRODUCTIVITY at your fingertips.

- a SORTED Master Catalog of ALL your Disks (even those un-listable "protected" Directories: Names, ID's, File info, etc.)
- Search + List any File/Disk/ID in seconds, automatically, in any of SEVEN WAYS.
- Transfer ML-Programs or Files from Disk to Disk (CATEGORIZE your software)
- Stop disaster before it strikes: change duplicate ID's fast, without total re-copy.
- Restore accidentally-scratched files in a flash, with VERIFICATION that they're OK.
- Works with 1 or 2 Single Disk Drives (1541, MSD, etc.) with or without Printer (Commodore or ASCII).
- Handy-Reference Card for HEX/ASCII/BINARY-TO-DECIMAL VALUE TRANSLATION + FORMULAS, included FREE.
- All this + MUCH MORE, for just \$34.95. (U.S.A.)

MASTERDISK® and **MASTERDUAL**® are both also compatible with the NEW C-128 (in C-64 Mode)!

INTEGRATED-SOFTWARE SYSTEMS
VISA/M.C./C.O.D., call (515) 233-2992
9 a.m. - 9 p.m. (Central Time) Mon.-Fri.,
Add \$3 Shipping/plus \$2 Foreign, C.O.D.
IA Residents add 4% Sales Tax.

From This:



To This:



Now YOU too can get the "Software Edge"!

NEW!! - MASTERDUAL®, "Son of MASTERDISK"® . . . same power, but with Dual Drive Speed!

- Same Catalog Features as MASTERDISK®
- Same Disk repair functions, too
- For all C-64 & C-128* systems with Dual Disk Drives (4040, MSD, etc.)
- Utilizes all Dual Drive functions for maximum speed and ease of use
- FREE Handy Reference Card for HEX/ASCII/Binary to Decimal Translation
- Experience FULLY-INTEGRATED POWER for just \$29.95 (U.S.A.)

IN CANADA: Cricket Distribution Co.,
616 Mackechnie Crescent, Cobourg,
Ontario, Canada K9A 4X8
Call (416) 372-3692 for prices and shipping information
9 a.m. to 6 p.m. (Eastern Time) Mon.-Fri.

Whether you have tens or hundreds of disks, now YOU can be the MASTER of your TOTAL Software Library!

Circle Reader Service No. 11

Inside the 1541

Riddle: What looks like a disk drive, runs like a disk drive, but is more than a disk drive? The Commodore 1541, of course! As experienced Commodore computer users know, their disk drives are much smarter than other brands of disk drives. In fact, the microprocessor found in the Commodore 1541 disk drive runs much faster than the microprocessor in the Commodore 64 computer. All of this power and intelligence really helps make for easy use. However, to really understand your 1541, you must learn about its unique microprocessor and how it communicates with your Commodore 64.

Several books have been published that describe the workings of the 1541. I have reviewed three of them: *Commodore 1541 Disk Companion*, *The Anatomy of the 1541 Disk Drive*, and *Inside Commodore DOS*. Because each book is unique—even though they all concern the same hardware—I'll look at them individually, rather than compare and contrast them.

The Commodore 1541 Disk Companion

Authors: David Lawrence and Mark England

Publisher: Commodore Business Machines
1200 Wilson Drive
West Chester, PA 19380

This book is an inexpensive in-depth substitute for the 1541 user's manual. Many topics are covered in more detail, but in a presentation geared toward the novice.

The first few chapters explain what a disk drive is, how to hook it up, and the commands needed to use it. These chapters are especially valuable to the novice. However, the authors have gone into a little too much detail, and the novice may not be able to follow.

The remaining chapters discuss how to actually use the 1541. Almost all of the disk commands are discussed in detail, but without some of the obscure references found in previous chapters. This is the core of the

Three books provide a close look at the inner workings of the Commodore 1541.

book and is well done.

Sample programs are given that are short and surprisingly useful. There is a routine to provide program listings with readable abbreviations for special codes (such as cursor left). There is also a routine to renumber program lines, merge programs, restore scratched files, read the disk directory, and manipulate file names.

The text and sample programs give a novice a good start on getting the most out of the 1541. The only defect, in fact, is the omission of the sequential file append.

The Anatomy of the 1541 Disk Drive

Authors: Lothar Englisch and Norbert Szczepanowski

Publisher: Abacus Software
P.O. Box 7211
Grand Rapids, MI 49510

While the preceding book was meant for new computer and disk drive users, this book is definitely for the more experienced programmer,

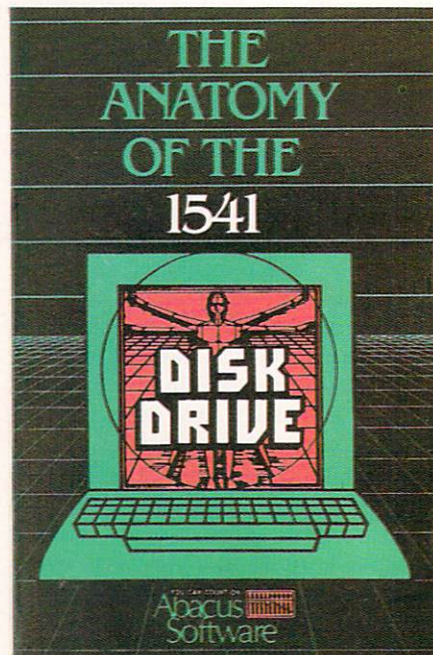

and should be considered a reference work. *The Anatomy of the 1541 Disk Drive* is 322 pages of information that includes a commented machine code disassembly of DOS 2.6, the program that runs the 1541 disk drive.

This book covers much territory. It even includes material that doesn't directly relate to the disk drive. For example, the section on appending BASIC programs describes a method that appends programs in the Commodore 64. Chaining programs really concerns BASIC programming, not the disk drive per se. However, it is still very useful.

The book covers sequential and relative file storage in great detail, but has a very short discussion of direct access. In comparison, five pages are devoted to DOS 4.0 commands, while only 1-1/2 pages are devoted to the uses of direct access. Also, the section on 1541 construction is terribly short, and the drive electronics diagram is lacking.

But perhaps the most significant shortcoming is the lack of explanation about DOS operation. One and one-half pages are devoted to a short overview of DOS tasks and timing. The authors assure us that all the best information is in the commented machine code listing. While this is true, everyone needs a better introduction to 151 pages of machine code.

The DOS listing is very useful for the serious programmer. There are

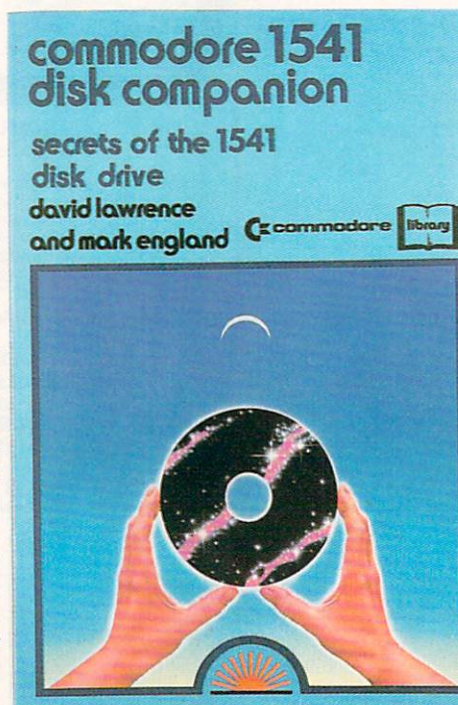

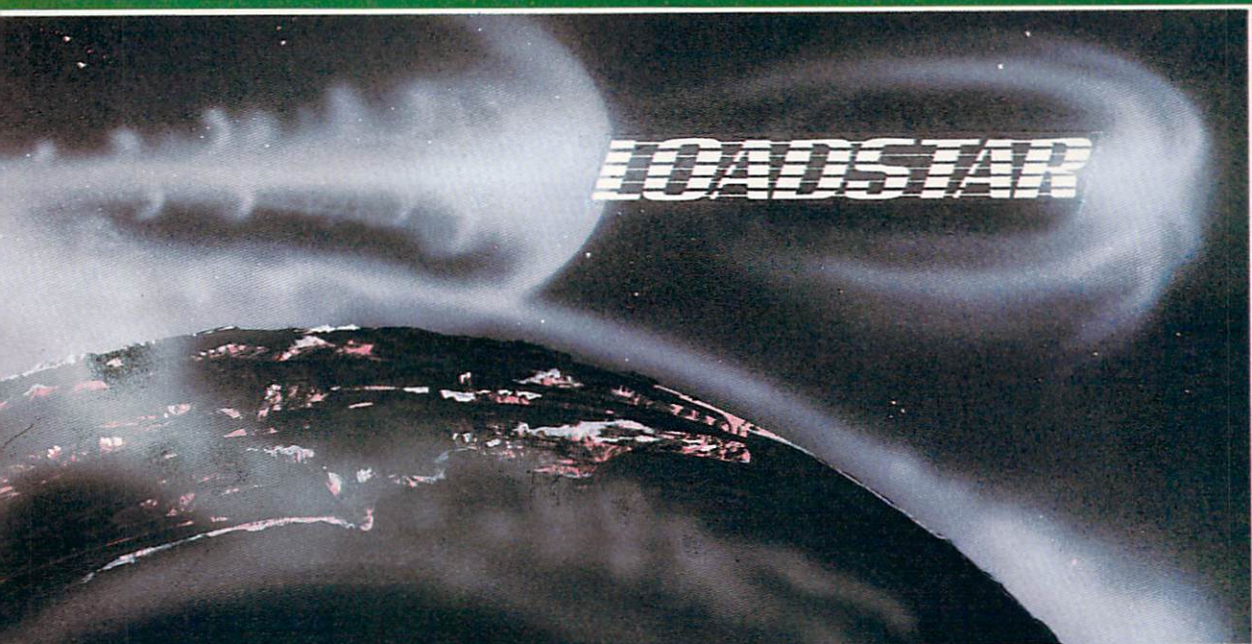

Unique in the Universe.

Loadstar is like no other disk-based magazine on the market. Loadstar is a two-sided diskette jam packed with ready-to-run unprotected programs for your Commodore-64.

Loadstar is published monthly. One month features the C-64 programs from *Commodore Microcomputers* and the next month features the C-64 programs from *Power Play*. What's more, every issue of Loadstar contains feature articles and programs which are not contained in either magazine.

Loadstar will make your favorite magazines even better. Having the program listings already on disk is a real finger saver.

Loadstar is not just programs on a disk, it is an information network that invites you to take part in the action. Try an issue. If it doesn't meet your expectations, no matter what they are, return the disk and we'll give you your money back!

to order by mail
send to:

LOADSTAR
P.O. BOX 30007
Shreveport, LA
71130-0007

- \$ 9.95 for the current LOADSTAR disk companion to *Power Play*
 \$ 9.95 for the current LOADSTAR disk companion to *Commodore Microcomputers*
 \$39.95 for the next 6 issues of LOADSTAR
 \$69.95 for the next 12 issues of LOADSTAR

name _____

address _____

city/state _____

zip _____

VISA/MC number _____

exp. date _____

FOR IMMEDIATE SHIPMENT CALL TOLL-FREE:

1(800)831-2694

8-5 CENTRAL TIME

The disk Companion to

power
play
commodore
microcomputers

Sensational Prices!

... On Our Most Popular Items!

Introducing . . . THE 99¢ DISKETTE

Are you paying too much for diskettes? Try our first quality, prime, 5 1/4" diskettes (no rejects, no seconds) at these fantastic sale prices and save, save, SAVE! Disks are packaged in boxes of 50; each box contains 5 shrink-wrapped 10-packs that include diskettes in sleeves, labels, and write-protect tabs.

Each diskette is certified to be 100% error free and comes with a lifetime warranty (if you have a problem, we'll replace the diskette). All diskettes include hub reinforcement rings and write-protect notch.

All diskettes are double density and work in either single or double density drives.

SS, DD Diskettes, Box of 50
32391 **\$49.50**—\$99c ea.!

DS, DD Diskettes, Box of 50
32403 **\$64.50**—\$1.29 ea.!



LOWEST PRICES!

We can offer you some of the lowest prices in the country on the most popular printers, monitors and interfaces. Our normal prices are already low, but to make sure you get the best deal you can, we will also meet most competitive prices in this publication when placed on an equal basis (Remember—we don't charge for use of your credit card, impose excessive shipping fees, or use any other hidden extras to boost the price you pay. Due to the rapid change in prices in the computer industry, we can only meet prices at the time you place your order; we cannot adjust prices on items ordered or shipped on an earlier date.) Another plus for charge card customers—your charge card is billed at time of shipment only for the items shipped—no early billing, no long wait for the merchandise you already paid for.



EPSON
BMC
AXIOM
CARDCO

★ THE BEST PRICES ★ THE BEST SERVICE ★
WHY SHOP ANYWHERE ELSE?

COMPUTERFACTS™ from SAMS

Technical Service Data for Your Computer and Peripherals

Sams introduces COMPUTERFACTS™ . . . packets of information that reveal the inner workings of major brand micros, monitors, printers and disk drives. Includes schematic wiring diagrams, parts lists, disassembly instructions, troubleshooting techniques, and other repair data.

33477 Commodore 64 Computer
33513 VIC-20 Computer
33551 Commodore Plus/4 Computer
33481 Commodore 1541 Disk Drive

33496 Commodore 1525 Printer
33508 Commodore C16 Computer
33546 Commodore 1701 Monitor



All packets
\$17.95 each

The Most Complete Disk Drive You Can Buy

Includes Word Processor, Spread Sheet, and
Data Base Manager

INDUS GT ONLY \$259

State-of-the-art disk drive for C-64 and VIC-20 features LED sector indicator, electronic write-protect, built-in wedge, and operating speeds up to 400% faster. Package includes cables and power supply, carrying case that doubles as a disk storage file AND software starter package featuring word processor, spreadsheet, and database manager program!

FULL YEAR PARTS AND LABOR WARRANTY!!

33443 Indus GT Disk Drive **ONLY \$259**

GRAPHICS PRINTER INTERFACE



The PPI (Parallel Printer Interface) from DSI is a high-performance graphics printer interface for your Commodore 64 or VIC-20, offered at an unbelievable price! The PPI fully emulates a Commodore printer so that all software written for Commodore computers and printers can be run with the PPI and most any parallel printer. Print true Commodore graphics and alpha-numeric as well as any special character sets offered by your specific printer. Works with Star, Epson, BMC, and many more. Comes complete with all necessary cables for quick installation and includes easy-to-follow user's manual.

\$44.95

33565 Parallel Printer Interface

CARTRIDGE EXPANDER



Plus \$22.95
FAST LOAD
OFFER!

Stop wearing out your computer and cartridges by endless swapping! New design cartridge expander features two cartridge slots. Select either cartridge, or the "off" position if no cartridge is to be used. Reset the computer independently of the power switch. Cartridge slots are vertical for easy access—no blind fumbling behind the computer.

34220 2-Slot Cartridge Expander **\$19.95**

The cartridge expander is a great companion for the Epyx Fast Load cartridge—you can keep it permanently installed plus have a slot free for other cartridges!

34216 Fast Load Cartridge (Sug. Retail \$34.95) **\$29.95**

Fast Load ONLY \$22.95
with purchase of cartridge expander!

DUST COVER and "EVERYTHING BOOK" INTRODUCTORY SPECIAL

Get to know us by ordering this great dust cover for your VIC-20 or Commodore 64 and our catalog, "The Everything Book for the Commodore C-64 and VIC-20 Home Computers," for \$2.95 (no extra shipping or handling charges). Cover is antistatic, translucent, 8 gauge vinyl sewn to our exacting standards with reinforced seams. Discover the savings and easy shopping available from Tenex Computer Express!



\$2.95

31627 Dust Cover and Catalog

USE SINGLE SHEETS IN YOUR TRACTOR FEED PRINTER WITH

PAPER TRACTOR™

Paper Tractor carries ordinary sheet paper through your tractor—feed printer! Simply place your letterhead, checks, invoices, forms, even legal—size sheets into the durable flexible plastic carrier and feed into your adjustable tractor—drive printer. Works with any printer, carries any paper.

\$11.95

22084

From Your Friends At



We gladly accept
mail orders!

P.O. Box 6578
South Bend, IN 46660

Questions? Call
219/259-7051

Ad
J1A

SHIPPING CHARGES

ORDER AMOUNT CHARGE	
less than \$20.00	\$3.75
\$20.00—\$39.99	4.75
\$40.00—\$74.99	5.75
\$75.00—\$149.99	6.75
\$150.00—\$299.99	7.75
\$300 & up	8.75



NO EXTRA FEE FOR CHARGES

NO HIDDEN EXTRAS

ORDER TOLL FREE

1-800-348-2778

BOOK REVIEWS

also numerous utility programs for users of every kind. There are relative file and sequential file database programs. A disk machine language monitor is included. There are programs for unscratching files, searching and sorting tables, backing up disks, and inputting and manipulating strings. There is even a program that sends a text file directly to the printer, allowing you to use your Commodore 64 in the meantime.

The book also contains a reference section about the programs that are included on the test/demo disk that comes with the 1541. This, along with the book, is a good reference I recommend for anyone's library.

Inside Commodore DOS

Authors: Richard Immers and Gerald G. Neufeld
Publisher: Datamost
 19821 Nordhoff Street
 Northridge, CA 91324

Inside Commodore DOS has the usual description of the BASIC disk commands (augmented with the DOS

5.1 syntax), and there are no extensive file-handling examples. Here is pure technical information about the 1541's workings. The book has 20 pages of description of the 1541 RAM memory usage and 204 pages of detailed description of the 1541 DOS by memory location.

One chapter is devoted to fixing disks that have gone bad and another is devoted to disk protection schemes. These chapters contain 35 pages of thorough examination. If you are using a Commodore disk drive for important work, I unconditionally recommend this book for chapters seven and eight alone.

However, some people want the whole story. The 1541 is a complicated animal, and it takes a keen understanding of the beast to train it to roll over, sit up, or jump through a hoop. In other words, the real hobbyist programmer wants to know how to run the Commodore 1541 disk drive from the inside out. The authors of this book have done a fair job of describing the 1541 DOS, and they

provide a good introduction to its operation. Though it's only an overview, it's a good one at that.

What makes this book unique is the massive number of programs. Some readers may want to disregard the intense discussion of the disk drive and use only the programs. If you are mainly interested in the programs, you can also save yourself some typing: Datamost offers all of them on a disk.

If you are a novice to programming, but still want to do more than load and save programs on your disk drive, the *Commodore 1541 Disk Companion* is an inexpensive reference. If you want an annotated listing of the 1541 DOS, with lots of reference material on other disk drives and detailed use of relative and sequential files, take a good look at *The Anatomy of the Commodore 1541 Disk Drive*. For a true understanding of the Commodore 1541, protection schemes, and information on resurrecting bad disks, consider *Inside Commodore DOS*. C



TYPING TUTOR + WORD INVADERS

Learn to use your keyboard quickly and properly. TYPING TUTOR starts with the 'home keys' and automatically evaluates your typing performance, introducing you to new keys in many gradual steps as your skills develop. WORD INVADERS puts real excitement into your touch typing practice while reinforcing proper typing techniques.

"This is the best typing tutor we have seen yet; ★★★★★" **INFO-64**

"Best typing tutor I've seen — Better than Mastertype"

Microcomputer Courseware Evaluation

"WORD INVADERS is fantastic"

Editors of Consumer Guide

NEW! Commodore Plus/4 or 16 Tape \$21.95 Disk \$24.95
 Commodore 64 Tape \$21.95 Disk \$24.95
 VIC 20 (unexpanded) Tape \$21.95

IFR (FLIGHT SIMULATOR)

Put yourself in the pilot's seat! This program provides a very challenging, realistic simulation of flying under Instrument Flight Rules (IFR) in a single engine light plane. Realistic instrumentation and aircraft performance. Plenty of thrills for pilots and non-pilots alike.

"It is tremendous fun."

Compute's Gazette

"It's a great program, and as a pilot I found it to be very realistic. My brother, a current commercial pilot and a former Air Force flight instructor with over 3,500 hours in military and civilian aircraft was also quite impressed."

Private Pilot

NEW! Commodore Plus/4 or 16 Tape or Disk \$29.95
 Commodore 64 Tape or Disk \$29.95
 VIC 20 (unexpanded) Cartridge \$39.95



The Intelligent alternative to overpriced 64™ software

The Intelligent Software Package for **C-64™, VIC™, SX-64™, C-128™, LCD™, Plus 4™, 16™, B-128™, and PET/CBM™**. An integrated home/business/educational package of 25 powerful, useful programs (totaling over 51 pages of source code) that will put your Commodore to work right now, in your home or office; all on disk or tape at the ridiculous price of **\$35**, or about \$1.40/program. One customer writes: ". . . This is as slick a deal as I have seen and more than adequate for all except fancy presentations. The best thing is the ease of use . . ." The package includes:

Database: A complete multi-keyed fixed-record-length data base manager. Sort or select (using all relational operators: =, >, <, AND, OR, NOT, wild card) on any field, perform computations on numeric fields. Any operation can be performed on all, or only selected records. All fields completely user-definable. Can be used for any number of tasks, including accounting, mailing lists, inventory control, record, tape, or book cataloging, expense account maintenance, or as an electronic rolodex. Even if you use your Commodore for nothing else, this program alone might justify its expense.

Word Processor: A full-featured menu-driven word processor including: very fast file commands, screen editing, text locating and full control over margins, spacing, paging, indentation, and justification. ". . . well done and highly functional . . . Provides an excellent alternative to the high priced word processors . . . this is an excellent buy. Highly recommended." — Midnite Software Gazette. "Provides good basic features." — Compute's Gazette.

Copycalc: An electronic spreadsheet. Turns your Commodore into a visible balance sheet; includes screen editor. "Excellent program for budgeting, estimating, or any math-oriented use . . . well worth the money. Highly recommended." — Midnite Software Gazette.

Also included: **ReportGen, ReportMerge** (interface W/P with Database to create form letters, statements, invoices, mailing labels, other reports.); **Baseball Statistician** (compiles batting statistics for a baseball league); several W/P utilities, including **Index** (indexes W/P's text files); several Database utilities, including **DBmerge** (facilitates multi-file database applications.), and **DBStat** (analyzes D/B files); a programming utility, **ASCII**, which converts text files (program listings) into program files; also **Checkbook, Inventory, Paper Route, Loan Analysis, Breakeven Analysis, Depreciation, Labeler, File Copier**; more.

Versions of the package are available for every Commodore computer having a minimum of 10k RAM; please specify regular disk, 8050 disk, or tape format (disk only for Plus4™ and 16™.) All programs support tape, disk, and printer; price includes documentation and shipping. Calif. residents add 6%. Visa/Mastercard, add \$2; no personal checks from outside USA. This ad is the catalog; a sampling of program output is available for \$2.

Intelligent Software
 Quality Software since 1982

Box A Dept. C-2
 San Anselmo, CA 94960
 (415) 457-6153

ACADEMY SOFTWARE



Shipping and handling \$1.00 per order. CA residents add 6% tax.



P.O. Box 6277 San Rafael, CA 94903 (415) 499-0850

Manager Mania

I have compiled a list of the questions that are frequently asked about *The Manager*, Commodore's database manager for the Commodore 64, and have tried to answer them clearly. The questions answered in the greatest detail are those that are asked most frequently. The others are simply ideas to keep in mind while setting up your data base.

Q: Why when I am creating a report does only one field print out?

A: This seems to be the most common question about *The Manager*. The answer lies in one prompt in the list zone of the report-generate mode. Once in the list zone, *The Manager* will prompt you for field type, subscript, length of area, line number, column, and lastly, centering.

The error often occurs after the centering prompt, where *The Manager* must be told to advance to the next print area. Frequently, the back arrow is incorrectly used to do this. Unfortunately, the back arrow tells the program that you are done with the list zone, you wish to define only this one print area, and this is what you wish your report to look like.

Instead, in order to move to the next print area and define your next field, you should, after answering yes or no to the centering prompt, hit the F7 key—not the back arrow. You will then be presented with another list zone screen, but the "print area" indicator at the top of the screen will say PRINT AREA#2. You can now proceed in the same fashion as you did for print area one, but must remember to change the subscript number to coincide with the field number. You can continue pressing F7 after the centering option to do more print areas.

After you have defined all your fields and you are ready to exit the list zone, use the back arrow, which will bring you back to the DEFINE PRINT ZONE screen. From there you can define your footer or simply exit.

Q: How do I create an index search and have it printed in a report form?

A: The easiest way to explain how to set up an index search is to show an

Commodore's database manager for the Commodore 64 is complex, but extremely versatile, once you get the hang of it.



example of one. Let's say that we have created a simple mailing list, which looks like this after we have entered data in the enter/edit mode:

```

NAME
[John Smith ]
ADDRESS
[40 Archway Pl. ]
CITY
[Philadelphia ]
STATE
[Pennsylvania ]
ZIP
[19104]

```

An index search sorts the field according to the index file, pulls out the field you have designated in the search, and prints these fields on the screen or printer. For this example, we are using the search option in report-generate mode, so the records we are pulling out will be listed in a report form.

Since the screen in the example above has the state as Pennsylvania, we will set up our index search to pull out all fields which have field four as

Pennsylvania and sort these fields by field one, the name field. First, we have to create the index file in enter/edit mode. So, from the main menu enter E. Once in enter/edit, you will see some letters and graphic characters like this:

```
A,E,F,G,I,P,S,↑,=
```

The first step is to press SHIFT I. The computer will then prompt you with:

```
FIELD NUMBER?
```

Here you supply the field number you want *The Manager* to sort by. For our example, it would be:

```
FIELD NUMBER?1
```

After you press [RETURN], the computer will show you the field you chose to index by, along with the field's index number. For our example, it will show all the names which appear in field one, along with their index numbers.

Now that the index file has been created, we want to save it to disk. Returning to the main menu will accomplish this, so after your index file has been created, press the F1 function key. The computer will prompt you with ARE YOU SURE? A Y response will return you to the main menu.

To see if your index file was created, check your disk directory by pressing D from the main menu. Make sure your data disk is in the drive. Once you are in the disk directory, you will have three choices:

```

EVERYTHING
MANAGER FILES
REPORT FILES

```

```
ENTER SELECTION?
```

Choose M for MANAGER FILES. This will show you all the data files you have created with *The Manager*. If your index file was created, there will be an "IN." in front of the file name you created the index for. If your index file was created, return to the main menu. We can now define the search criteria.

Once at the main menu, choose R for report generate. The computer will prompt you with:

```
ENTER SEARCH CRITERIA:
```

For our example we would enter:

```
F4 = "PENNSYLVANIA"
```

This tells the computer that only the records which have Pennsylvania in field four (state) will be pulled out.

The F signifies that the data is alphanumeric. If you wanted to search by a numeric field, you would specify this by using an N and the field number. When you use an alphanumeric field, the field name has to be in quotes (a numeric field doesn't).

To save the search criteria, press the back arrow. This will bring you to the prompt:

IN ORDER BY INDEX, SORT, OR FILE?

For our purposes, we would choose I for index. This prompt is important because this is what tells the computer to access the index file when running the report.

This is the last prompt that is needed to set up the index search. After pressing [RETURN], you will be prompted to define your print-zone parameters. Once this is completed, your output will show all the records which have field four as Pennsylvania, sorted by name.

Q: How do you sort a file using *The Manager*?

A: A sort must be executed in the report-generate mode. The first prompt you answer to select the order of your report will be:

IN ORDER BY INDEX, SORT, OR FILE?

In this case, we want to sort, so press S and [RETURN] at this prompt. When you choose this option, *The Manager* will prompt you to:

ENTER NUMBER OF SORT KEYS?

The sort keys are the fields you want *The Manager* to sort by. You can have up to 16 sort keys, so you can sort by up to 16 fields. After choosing the number of fields and pressing [RETURN] at this prompt, you will be prompted with:

FIELD LEN ALPHA/NUM ASCD/DESD

Type in the first field you want to sort by. After you press [RETURN], the LEN, which is length of the field, will be automatically computed. Pressing [RETURN] at LEN will bring you to ALPHA/NUM. ALPHA is an alphanumeric field and NUM is numeric. *The Manager* will automatically place either an A or N here, depending on which you had specified in create/revise mode.

Press [RETURN] and you will be placed under ASCD/DESD. Here, type either an A or D to specify whether

To create an index search in report-generate mode, you must first save your file as an index file when you are in enter/edit mode.

you want your report to be sorted in ascending or descending order. When finished with this line, press the back arrow. If you have chosen to sort by more than one field, you will move to the next line of the table, where you should repeat the procedure just described, for the next field you want to sort by. Once you have finished defining your sort conditions, the back arrow will take you out of the sort option and allow you to next define the output of your report.

Q: How do you create a report using only certain fields from a record?

A: This is not to be confused with a search, which will print out selected records from a file, but prints only whole record(s). Since search will not allow you to select only certain fields for a report, you must use another method.

This can be done through a simple modification of the report in report-generate mode. From the main menu, enter R for report generate.

The first prompt *The Manager* will give you is:

REPORT FROM KEYBOARD OR DISKFILE?

If you are using a report which has been defined in the report-generate mode and saved to disk, you can type in D at this prompt for disk file. If you have not gone through report generate and saved the report, you have to type in K for keyboard.

If you choose disk file, your first prompt will be:

DO YOU WISH TO MODIFY THE REPORT?

A Y at this prompt will allow you to enter the report saved to disk and modify it. If you chose keyboard, you will not get this prompt, instead *The Manager* will prompt you for the

search criteria.

In either case, the main objective is to get to the list zone. It is in the list zone that you choose the fields you wish to print out. The main prompt which we are concerned with in the list zone is the subscript, which is equivalent to field number. (If you would like to view the fields with their corresponding subscript (field) numbers, you can press the shifted up arrow in enter/edit mode. This will highlight the fields you created in create/revise mode, and display their field numbers at their respective positions.) Once you have the field numbers, you know which subscripts to define. To get the report to print out only certain fields, you define only these fields in the list-zone option.

To further clarify this, let's look at an example using the mailing list we talked about previously.

Suppose we want to create a report that prints out only the name and the state fields of each record. To do this, we will be defining only two print areas. We will be defining the name field first in print area one. The subscript for this is a one, since we are defining field number one. After you press [RETURN], the computer will give you the length of the field at the LENGTH OF AREA prompt. The line number and column number prompts designate the position at which you want the data printed out. Choosing centering allows your fields to be centered on the page.

After answering Y/N at the centering prompt, use the F7 key to advance to the next print area. At the top of the screen, you should now see PRINT AREA #2. In this print area, we can define the second field we want to print out, the state. The subscript will now be changed to four, since we are now defining field number four. When you reach the centering prompt, respond with a Y or N, but this time do not press F7. Since we are finished defining the two fields which we want to have printed out, simply press the back arrow to save the report conditions and exit from the list zone.

After the back arrow is pressed, you will see:

DEFINE PRINT ZONES:

Press the space bar until DEFINE EXIT

Continued next page

is displayed on the screen. Press [RETURN] and *The Manager* will then prompt you with:

ARE YOU SURE?

Respond with a Y and press [RETURN]. You will then be prompted for:

SAVE THE REPORT CONDITIONS?

Respond with a Y at this prompt to save the report conditions to disk. If you do not respond with a Y, you will have to define your print zones all over again. It is easier to save them and then go back and revise. After you press [RETURN] the screen will read:

ENTER REPORT FILENAME:

In selecting a report file name, you should choose a name different from your original file name. After choosing the file name, press [RETURN] and *The Manager* will save your report to disk.

Q: How do you scratch a file using *The Manager*?

A: The SCRATCH A FILE option is located in manipulate files mode, so, from the main menu, enter M. The manipulate files menu will now be on the screen. Enter S for SCRATCH A FILE.

The Manager will prompt you with:

ENTER FILE NAME:

Make sure you enter the file name you want to scratch exactly as it appears in the disk directory. Before you press [RETURN] at this prompt, make sure your data disk is in the drive. If it is not, *The Manager* will not prompt you for it and will appear to have scratched the file from your disk.

After this is completed, press [RETURN]. You will then be prompted with:

ERASE THE MATH, DATA, OR INDEX FILES?

All three of these files cannot be erased at once. They must be scratched one at a time. So if you have a file created with math, data and index files, you will have to perform the scratch three times.

After responding with an M, D or I, press [RETURN]. *The Manager* will give you a chance to change your mind by prompting you with:

ARE YOU SURE?

Respond with either Y or N. An N will abort the scratch and return you to the manipulate-files menu. A Y response will cause the drive to scratch

When you scratch a file, be sure your data disk is in the drive. The Manager will not prompt you for it, and will appear to have scratched the file.

the file specified and return you to the menu.

To see if your file has been scratched from the disk, you can check the disk directory. From the menu, enter D. You will then be asked:

EVERYTHING
MANAGER FILES
REPORT FILES

ENTER SELECTION?

Choose M for MANAGER FILES. If your file was scratched correctly, the file name should not appear here. If your file still exists, you should check to see if you typed in the file name correctly and if you had the data disk in the drive when the scratch was taking place.

Q: How do you access more than one record in an enter/edit search?

A: In the enter/edit mode, there are three possible searches you can use. The first is the F3, position-dependent search. When using this search you must type in the field contents exactly as you entered it in enter/edit.

To further clarify this, let's use our mailing list as an example. Assume we want to search by the city, PHILADELPHIA, which is field three. After you hit S for search, the screen will show you your blank fields. Cursor down to the field you want to search by, in this case field three. Then enter Philadelphia in the same position as it was entered in enter/edit mode. Then press the F3 key.

If you type in only part of the field, e.g., PHIL, the search cannot be performed. If you are using more than one field to search by, both of the fields must meet the search criteria in order for the field to be pulled out.

tered in enter/edit mode. Then press the F3 key.

If you type in only part of the field, e.g., PHIL, the search cannot be performed. If you are using more than one field to search by, both of the fields must meet the search criteria in order for the field to be pulled out.

The next search is F4, which hunts within a field. When using this search, you do not have to be as precise as with the F3 search. For our example, if we want to pull out the city Philadelphia, we do not have to type in the whole field, and it does not have to be in the same position as it was typed in enter/edit. You can also enter more than one search criteria, as in the F3 search, but not all of the search criteria have to be met for the record to be pulled out.

For an F4 search, you must start your search criteria in the first character space of the field. If you do not do this, it will read the spaces as part of your search criteria and not acknowledge any of your fields. After entering the search criteria, press F4.

The last search is the F5, or complex, search. This search was explained in the index-search example above, and works the same way when you use it in enter/edit mode. Just press F5 and you will be able to enter your search criteria. If you wanted, in this case, to search for Philadelphia, your search criteria would look like this:

F5 = "PHILADELPHIA"

If you have a space in front of your first character, you must enter this space in the search criteria.

When using any of these searches, you will get only one record at a time. In order to access the next record, just press the space bar. If you would like these screens to be printed out, you have to dump them one at a time. To do this, just hit "P" which will perform a screen dump of the record which is on the screen.

Hints and Suggestions

1. Before even loading *The Manager*, you should sketch on paper how you want your report to look. Decide where your fields are going to be located on the page and how long each field will be. This will make defining these parameters that much easier in the report-generate mode.

64 USERS ONLY

2. When creating your fields in create/revise mode, you should place brackets around the up-arrow field settings. This is so when you move to enter/edit mode, you will be able to designate where the fields start and end.

3. You can use numeric data only for calculations. If you want to change your field type to numeric, you can do this in create/revise mode. The prompt that allows you to do this is DO YOU WISH TO ALTER FIELD TYPES? Respond with a Y and press [RETURN]. The first field will be highlighted and the status line will read:

FIELD NUMBER 1—TYPE (A/N/ (left arrow) = END)? A

If you want to change the default value from alphanumeric to numeric, just type N and press [RETURN]. Continue with this process until you have defined all the field types, then press the back arrow to end.

4. When you change the length of a field in create/revise mode, all your data will be erased. To avoid this, do not revise the old file but create a new one. At the prompt CREATE USING AN EXISTING SCREEN (Y/N), respond with a Y and input the name of the file you want to change. You can now change the file without losing the data from the old file. To transfer the data to the new file, use the REAR-RANGE A FILE option in the manipulate files mode.

5. A display position is used to exhibit data or figures, which are computed in the arithmetic mode, on the screen in enter/edit mode or in your report if desired. Before defining your display position(s) in arithmetic mode, be sure to note in create/revise the column and line numbers of where your display(s) will be situated. (For more information on using arithmetic in *The Manager*, see *Commodore Microcomputers*, January/February and March/April, 1985.)

The Manager is a very complex database system with extensive capabilities. However, in order to gain the full usage of *The Manager*, you will need to do some trial-and-error testing. The best way to do this is to start with an easy mailing list and try all of the options available. After you feel comfortable with it, you can create some large and complex data bases. C

LEROY'S CHEATSHEET®

KEYBOARD OVERLAYS

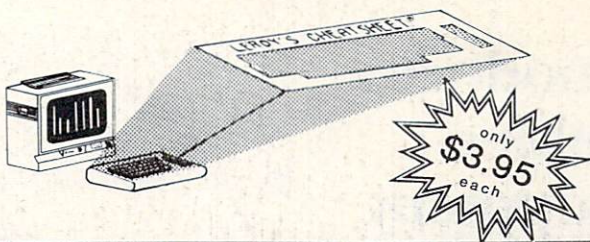

FOR COMMODORE 64

(VIC-20 also available)

LEROY'S CHEATSHEETS® are plastic laminated keyboard overlays designed for use with popular software and hardware for Commodore's VIC-20 & C-64 computers.

These cut-it-out yourself overlays are designed to fit over the keyboard surrounding the keys with commands and controls grouped together for easy references.

LEROY'S CHEATSHEETS™

make life easier for you

WORD PROCESSORS

- Easy Script
- HES Writer
- Paper Clip
- Quick Brown Fox
- Script 64
- Speedscript (2.0 & 3.0 GAZETTE)
- Wordpro 3/PLUS
- Omniwriter
- Wordpro 64 (By Steve Punter)
- Write Now!/64

SPREADSHEETS

- Calc Result (advanced)
- Calc Result (easy)
- Easy Calc
- Multiplan
- PractiCalc 64 (or PLUS)

DATA BASES

- The Consultant (Delphi's Oracle)
- The Manager (CBM)
- SuperBase 64

PRINTERS

- Printer (CBM) 1525, MPS 801, MPS 803
- Printer (CBM) 1526, MPS 802
- Printer (Epson) RX-80
- Printer (Gemini) 10X
- Printer Okidata 92 & 93

COM 7

MISCELLANEOUS

- Blanks (3 each - NOT Laminated)
- For The Beginner (using the 64)
- Sprites Only
- Flight Simulator II
- Doodle
- 1541 Disk

LANGUAGES & UTILITIES

- COMAL
- SIMON'S BASIC
- Basic
- Hesmon 64
- LOGO (sheet 1)
- LOGO (sheet 2)
- Pilot (CBM)

TERMINALS

- Vidtex
- The Smart 64 Terminal
- VIP Terminal
- Term 64

Dealer inquiries welcome

Name _____

Address _____

City _____ State _____ Zip _____

CHEATSHEET PRODUCTS™

P.O. Box 111368 Pittsburgh PA. 15238

VISA

master charge

(412) 781-1551

Charge My VISA or Master Card NUMBER _____ EXPIRATION DATE _____

... OR SEE YOUR LOCAL DEALER !

Qty. ___ X \$3.95 \$ _____

Shipping & handling \$ 1.00

6% sales tax \$ _____
(PA residents only)

TOTAL \$ _____

U.S. FUNDS
NO COD'S PLEASE

Circle Reader Service No. 4

Commodore's Assembler Development System for the Commodore 64

Commodore's assembler package contains five programs that make writing assembly routines easy.

The diskette supplied in Commodore's Assembler Development System contains five programs, which are the nucleus of the development system (Figure 1), along with several

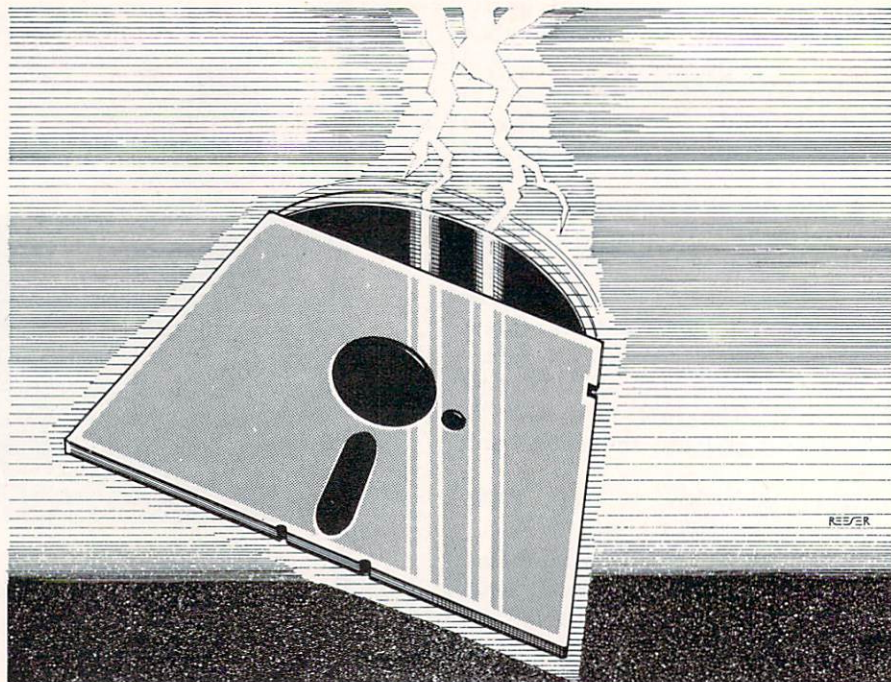

utilities. The utilities include a copy program for making backups of your work and the ubiquitous DOS wedge. The first four of the five major programs allow you to create an assembler input file (EDITOR64), assemble it to produce an object file (ASSEMBLER64), load the object file (HI-LOADER64 or LOLOADER64), and

execute the machine language program in a test environment (MONITOR\$8000 or MONITOR\$C000). The fifth program (CROSSREF64) produces a cross-reference listing from files written by the assembler.

Two versions of the loader and monitor are supplied because the system is oriented toward absolute code.

Figure 1. Assembler Development System Programs

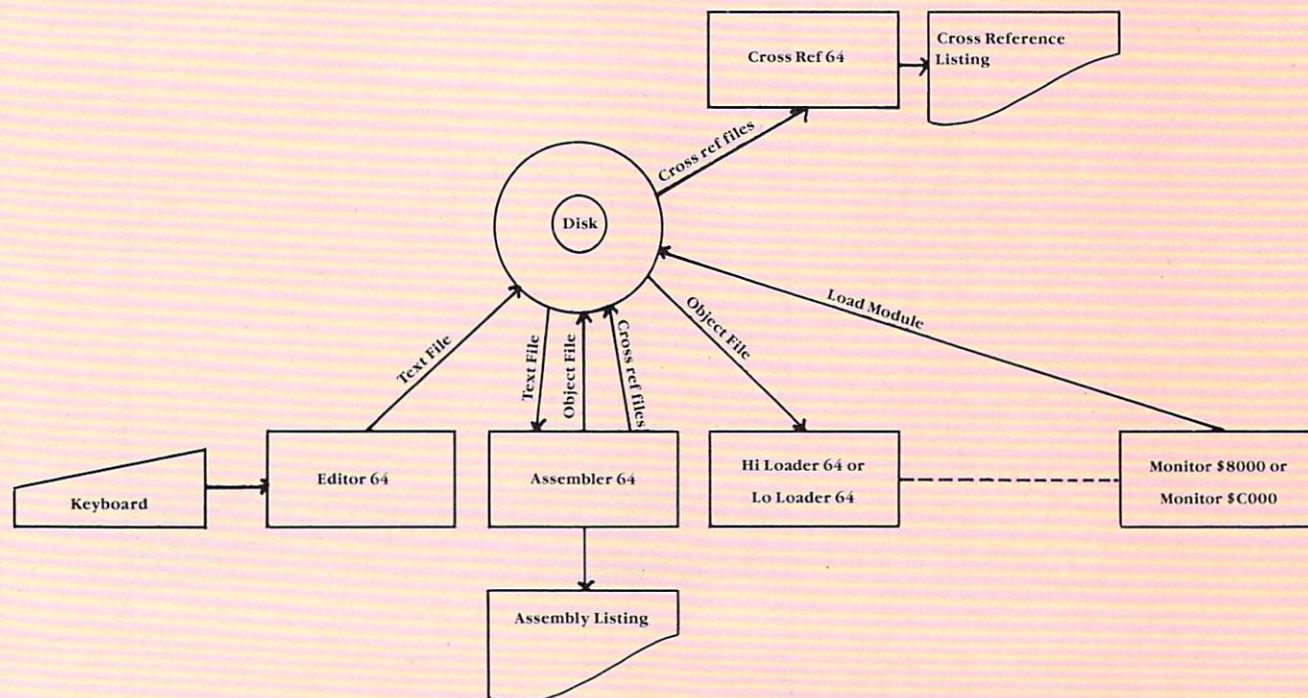

64 USERS ONLY

The two versions are functionally identical, but load at different addresses so as not to interfere with the program being developed. The system has no provision for linking or relocating object modules.

EDITOR64 is based on the BASIC full-screen editor that is located in the 64's ROM. It is a machine-language program that loads into memory at location \$C000, and it works like the DOS wedge. Once you have initialized it, you are back in BASIC but with a few extra capabilities. There is one major difference: BASIC can still be used in the direct mode, but program-mode entries (those with line numbers) are not tokenized and cannot be executed as BASIC programs.

Assembly language programs are entered in much the same way that a BASIC program is entered. You still have the full-screen edit capability, supplemented by line numbering and string-manipulation commands which are not available normally in Commodore BASIC. The editor has a KILL command which disengages it without removing it from memory so that you can restart it at any time without reloading it. The editor and the DOS wedge can both be active at the same time; they reside in different areas of memory and do not interfere with each other.

After you have entered your text, you save it as a disk file using the editor's PUT command, and then load the assembler. The assembler asks the name of the file to be assembled and then asks if you would like to produce an object file, and whether the files will be used as input to the cross reference program. Although it asks about both types of output files, both cannot be produced in the same run of the assembler. A listing is always generated, and can be directed to either the screen or the Commodore printer (or any other printer which is device four on the serial bus).

The assembler is a standard two-pass assembler with macro capability. It has two directives which partially compensate for the lack of relocatable code. The first of these allows you to merge text from another file into the assembler input stream, and the second allows you to chain input text files together.

The object file produced by the as-

sembler cannot be loaded with BASIC's LOAD command. It is an intermediate text file and must be loaded with one of the loader programs (HILOADER64 or LOLOADER64). Although this seems cumbersome at first, it has a distinct advantage. In a single assembly, you can direct the assembler to produce code for disjoint sections of memory and the loader will load the object code into only the locations that you intend to modify. Once the program has been loaded, you can execute it directly from BASIC, or you can read one of the monitors into a different part of memory and use the monitor to test the program. The monitors have commands that allow you to save the program (or

any other section of memory) on the disk in a format that can later be loaded and executed directly from BASIC.

Commodore's monitor is a relatively nice machine-language debugging tool. It contains commands to execute programs, examine and change memory, save programs as "load modules" for loading by BASIC, and load programs previously stored in load-module format. It contains a one-line assembler *and* a disassembler. It can move information from one section of memory to another and can relocate blocks of code to a different base address, although the programmer has to make the distinction between sections in which addresses should be relocated and sections in which they should not.

The monitor provides a primitive breakpoint capability. It does not set and remove breakpoints for you, but if your program contains BRK instructions, control will transfer back to the monitor when they are encountered. The only reasonable way to use the breakpoint is to sprinkle a program with NOP's and replace them with BRK's as needed in the course of debugging. The monitor also provides a HUNT command which will find specific data or sequences of data in memory.

The development system was designed to minimize the number of times that you need to load the system's programs. EDITOR64, the DOS wedge, and the HILOADER can all be in memory at the same time and do not interfere with each other (Figure 2).

During the usual three or four tries at getting an error-free assembly in which the editor, wedge and assembler are used repeatedly, only the assembler needs to be loaded from disk. The others remain in memory and can be activated and deactivated as required with typed commands. Unfortunately, this does not also apply to the monitors. Even though MONITOR\$8000 does not overlay the other programs, the entire computer must be reset and everything reloaded after either one of the monitors have been used. Although the documentation does not say so, the editor must be killed and the edge de-activated before the monitors can be used. **C**

Figure 2. Assembler Development

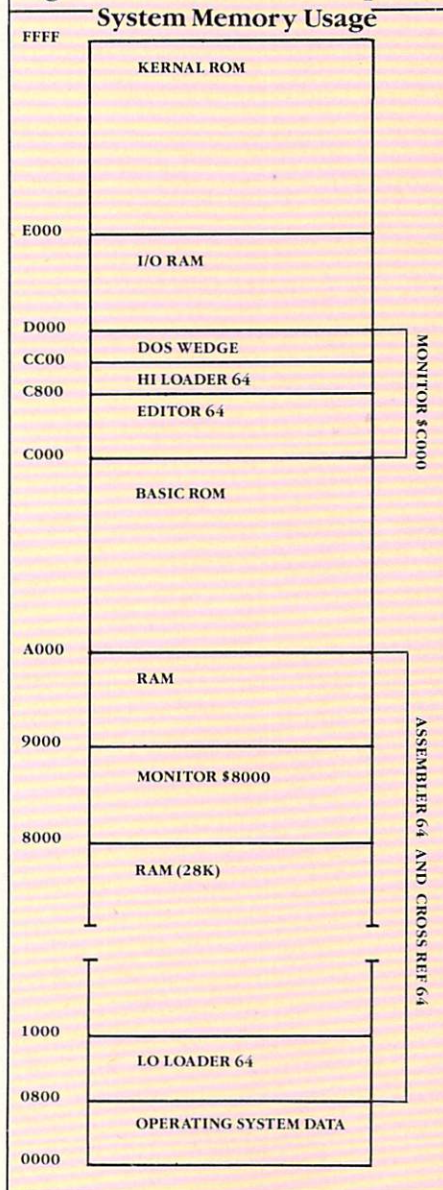

Chameleon for the Commodore 64

Chameleon converts your graphics screens from one graphics format to another (say, Koala to Micro Illustrator, for instance), lets you use these screens in your BASIC programs—and takes up no BASIC RAM. Believe it.

As most of you already know, there are quite a lot of different graphics packages currently available for the 64. While the types of hardware and software used may vary from one to another, these packages generally fall into two categories. The first type are multi-color painting packages—that is programs that take full advantage of the 64's high-resolution multi-color graphics mode. This mode allows up to four different colors in each of 1000 color cells on the screen while still using high-res bit-mapping techniques. These types of graphic programs include *Koala* (tablet and light-pen), *Micro Illustrator*, *Blazing Paddles* and others.

The other main category is composed of Computer-Aided Drawing systems (CAD) that take advantage of the 64's standard high-resolution graphics. This mode has twice the horizontal resolution of the multi-color mode, and is very useful for drawings that require as much resolution as you can get. And while it does not have quite as good color, it can still display two different colors for each of the 1000 color cells on the screen. Examples of these programs are *Flexidraw*, *Cadpak*, *Graphics Basic* and *Doodle*.

In addition there are several language extensions that provide graphics capabilities. Included in these are *Simons' BASIC*, *Super Expander*, *Graphics Basic*, *Video Basic*, *The Tool* and even *LOGO*. Some of these have both high-res and multi-color commands.

There is one additional feature each of these programs has in common: They cannot use graphic screens cre-

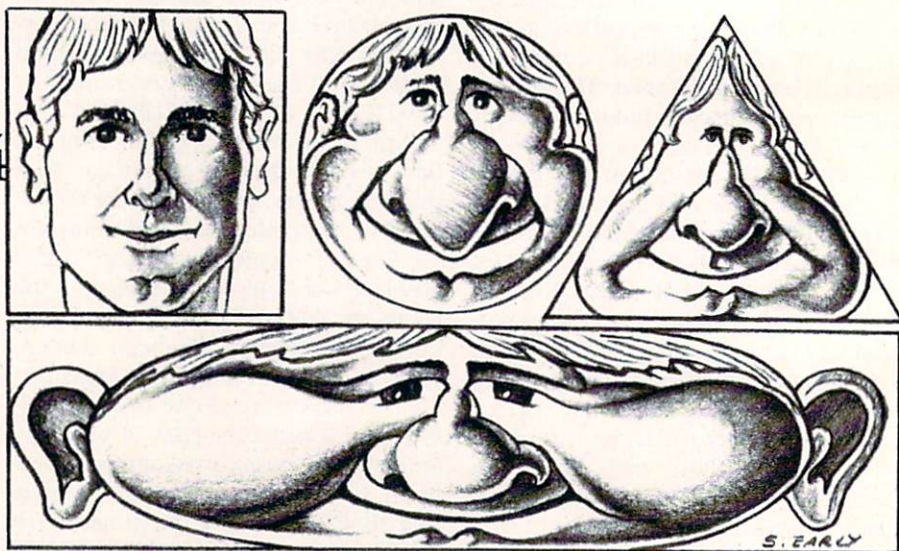

You might have imagined that one multi-color screen was stored just like any other, but sad to say it's not true. In fact, you could crash your favorite drawing program by attempting to load a picture made by some other package.

ated from another system. You might have imagined that one multi-color screen was stored just like any other, but sad to say it's not true. In fact, you could crash your favorite drawing program by attempting to load a picture made by some other package.

It would be quite useful to be able to create a graphics screen with one system, then edit it with another to take advantage of both programs' particular talents. It would also be very useful if you could use that picture in your own standard BASIC program easily, without resorting to a lot of complex programming. And finally, while we are wishing, it would be great if all of that took up no BASIC RAM, leaving you with all your normal programming space. Well, wish no longer, because that's what Chameleon does.

Chameleon

Chameleon is so named because it can convert a screen from one graphics package to another of the same type (high-res or multi-color). It is menu-driven, very easy to use, and will quickly become one of your favorite utility programs.

Some of you may have noticed we included *Simons' BASIC* and the *Super Expander* cartridges in Chameleon, even though neither one has the ability to save high-res graphics screens. While both have an extensive graphics command set, for some reason the commands to save and restore graphics were left out. So part two of this article will include a set of machine-language commands to save those screens. Since Chameleon already contains options for both, you will be able to convert pictures made with other programs to *Simons' BASIC* and *Super Expander* format, and vice versa, once you are able to save their screens to disk.

The third part of the article has still another set of commands for converting what we will call standard graphics screens from your own BASIC programs. You will be able to load, save and view pictures made with any of the packages listed on the Chameleon menus. And best of all, every bit of your BASIC programming space is still available to you.

The first thing you should do is very carefully type in the Chameleon program and save it. It is written mainly in BASIC, but you will notice a lot of SYS calls to machine-language

64 USERS ONLY

routines, especially in the portions of the program devoted to reading and writing the picture files. Then type in Chameleon II, which contains the machine language for Chameleon. This program should also be saved before trying to run it. Once both programs have been typed in and saved you can begin by running Chameleon II. This installs the machine language. Then load Chameleon and run it.

Chameleon is menu-driven, making it very easy to use. It has four main options; DISPLAY, QUIT, READ and WRITE. You may indicate your choice in one of two ways. You may use the cursor keys to move from one option to another. As you press the cursor keys the name of each option is highlighted, and you select by pressing RETURN. Or you can simply press, D, Q, R or W and no RETURN is necessary. In addition, when you are at the selection menus a CTRL \$ will give you a directory of your disk, which remains on the screen until you press the SHIFT key. And a CTRL 1 will give you a prompt that allows you to enter disk commands directly. This means you have RENAME, SCRATCH, VALIDATE, NEW and all the other DOS commands available.

The read option asks you to decide between standard high-res and multi-color modes. Choose the graphics type you wish to read, and a list of different formats will appear. If you choose high-res, you get the following list:

High-res Package Menu

- Cadpak
- Doodle
- Flexidraw
- Graphics Basic
- Logo
- Simons' BASIC
- Super Expander
- The Tool
- Video Basic
- C-64 Standard Screen
- Return to Main Menu

If you choose multi-color you get this list:

Multi-color Package Menu

- Blazing Paddles
- Graphics Basic
- Koala
- Micro Illustrator

Because you normally cannot save high-res screens using the Simons' BASIC and Super Expander cartridges, we have provided Programs 2 and 3, which allow you to save those screens.

- Peripheral Vision
- Simons' BASIC
- Super Expander
- Video Basic
- C-64 Standard Screen
- Return to Main Menu

The write and read options have the same format, except each indicates that it is writing or reading.

Lets run through it once. Insert the disk with the picture you wish to convert. Let's say it's a *Peripheral Vision* file you wish to convert to *Koala*. Choose the read option, indicate multi-color, and you will see the list shown above. Using your cursor keys, move the highlight (a reversed field) to the line which reads *Peripheral Vision*. Press RETURN and it will ask you for the file name. *Peripheral Vision* uses a two-file format, which means that it saves two separate files, one with the bit map and color, and the other just color. It prefixes the main file with the "£" sign (English pound) and ends it with .bmp. Just type in £ picturename.bmp and press RETURN. You are then given the chance to abort by pressing the asterisk key, or to continue by pressing F7. Press F7 and Chameleon will read in the file, automatically including the second color file, which has the suffix .cmp. This takes about twenty seconds, and you then return to the main menu.

After having read in a picture, you can look at it from the main menu with the DISPLAY option. The screen will display the picture in either high-res or multi-color, depending on the picture type. When you are displaying the picture, you can change the border color with F3, the background

color with F5 and also clear the display with the shifted CLR/HOME key. A clear not only clears the bit map, it also clears color memories. And you can return to the main menu by pressing the RETURN key. Also, if you change the background or border color, return to the menu and choose to write a file, the new colors will now be written (assuming the format you are going to stores those colors, which not all do).

F2 will toggle the continue/abort prompt on and off. This prompt will ask you if it should continue or abort the load/save process before reading and writing each file. If it is on, you will be asked to confirm each file read/write, and if off the color memories will be read in or written out automatically.

The picture files for the various graphic packages have certain naming conventions, and Chameleon expects to find them when it reads the files. They may consist of one, two or three separate files, and the different files making up each picture will each be tagged with a special symbol, prefix or suffix. For example *Koala* pictures all start with the reverse-spade symbol, followed by PIC A FILENAME. The A can be any letter, and the filename can be any word up to eight characters. To enter the special *Koala* reverse spade use the asterisk symbol, and Chameleon will convert it to the correct character.

Doodle starts each of its files with DD (ddfilename). If you want your new picture to conform to *Doodle's* naming convention add the DD when naming the file you are writing. If *Doodle* does not find those two D's it will not load. But don't worry, if you forget to put them on just rename the file with DD.

Flexidraw stores two files. The bit map is called filename.pic, and color (if it has any) is called filename.pic.gp. You do not have to have a color with *Flexidraw*, and if you don't have one then answer the prompt with "no" when asked if you want it loaded. Because *Flexidraw* saves its color in a very unusual way, you cannot write the color from a high-res picture to *Flexidraw*. However, you can take the bit map and paint it with *Flexidraw's Pen Palette program*.

Blazing Paddles writes its pictures

as pi.filename. *Micro Illustrator* writes them as pic.filename. *Simons' BASIC* and the *Super Expander* write their files with the same format. They are written as two files for a high-res picture with color, and as three files for a multi-color picture. The bit map is called filename, high-res color is filename.hr and the multi-color file as filename.mc.

The standard screen is saved as two files. The bit map is saved as filename, and color is saved as filename.hr if it is a high-res screen, and filename.mc if it is multi-color. The rest of them do not have any standard way of naming picture files, but for your own use it is good practice to include some kind of information as to its graphic type (i.e., .hr or .mc). Chameleon expects pictures to be named according to each package's conventions. If it is not correctly named, use CTRL 1 to enter disk mode and rename the file.

Saving *Simons' BASIC* and *Super Expander* Screens

Because you normally cannot save high-res screens using the *Simons' BASIC* and *Super Expander* cartridges, we have provided Programs 2 and 3, which allow you to save those screens. Once you are able to save them to disk, you can convert them to other graphics formats using Chameleon. Type in the version that you need, then save it. Only after saving it should you run it, because if you have made a typing error, it could have unpredictable results.

Once it is safely stored on disk or tape, type RUN. The only noticeable effect of running the program would be if you typed PRINT FRE(0), which would tell you that you have a little less memory than normal. *Simons' BASIC* users lose about .8K of RAM, while *Super Expander* users will lose about 1.5K.

The syntax is the same for both. There are four BASIC commands. One is to load, one is to save, one to go to high-res, and one to go to multi-color mode. The commands are accessed by using the BASIC command SYS, which allows a machine-language program to be executed from BASIC.

Here are the commands:

To load:

SYS BA, "filename",8 (or 1 for tape)

Chameleon is available on disk for \$16.95 as part of Loadstar's "Rich and Famous" series. To order, call Loadstar at 1-800-831-2694.

To save:

SYS BA + 3,0,"filename",8: save bit map

SYS BA + 3,1,"filename.hr",8: save high-res color

SYS BA + 3,2,"filename.mc",8: save multi-color

To go to high-res mode:

SYS BA + 6,0

To go to multi-color mode:

SYS BA + 6,1

BA = 32000 for *Simons'* and 31232 for *Super Expander*.

As you see there are three forms of the save command. This was done to give you the most flexibility. There are times when you may want to save only the bit map image, without saving color. In that case you would use only the first command and the bit map would be stored on disk for future use. Or perhaps you have a high-res picture with color you want to keep. In that case you would use the first and second save commands. In the second command, the .hr stands for high-res color.

Finally, if you have a multi-color picture you would use all three commands to save it. In the last command, the .mc stands for multi-color. On your disk you would now have three files that contained the information needed to restore the picture when you wanted it again.

Once you have a picture on file that you want to reload, you should use the load command above. Remember that you must reload two files for high-res and three for multi-color.

To go to high-res or multi-color, just include the appropriate command and presto, there you are! (Note: It is necessary to use these graphics commands *after* loading a file for viewing. *Simons'* high-res command will

clear the screen before switching to graphics mode.)

Program 4 is an example that demonstrates how to use the command set to load a multi-color file, look at it and then save it with a new name.

Now that you can save and restore graphics easily, think of all the programs you can write. Perhaps that game you've been meaning to do. . . .

Loading and Saving BASIC Screens

How would you like to be able to use high-resolution or multi-color pictures from standard Commodore 64 BASIC without a lot of messy complex programming? And would you like to have it without any loss of BASIC programming RAM? Of course you would, and now you can! Program 5 provides a set of machine language commands that you can use from BASIC to load or save those great graphics screens.

Perhaps the thing that makes this so useful is the fact that if you use Chameleon to convert pictures into this standard format, you have almost twenty different graphics programs available to you to design pictures on. These can be used for games, illustrations, help screens, slide shows or any other application you can think of.

The first thing to do is to type in the program, being very careful to type it exactly. The data represents machine language, and it must be perfect if it is to work. Once you have typed it in, be sure and save it before running it.

The program resides in the area of free RAM at 50176 (\$C400) through 53151 (\$CFFF). It also uses 8000 bytes under the kernal for its bit-map display. Because of the screen move, you will now have to store all sprite data at locations above 49152. Locations from 49152 (\$C000) to 50175 (\$C3FF) are available for those purposes. In addition you can store three sprites in the last 192 bytes of memory in the computer. Those last sprite addresses are 65344 (#253), 65408 (#254) and 65472 (#255). Since the VIC II chip is now looking at the last 16K of memory for its information, one other thing has changed. The sprite pointer locations that were at 2040-2047 are now at 53240-53247 when you are looking at the graphics screen. So to

64 USERS ONLY

tell the computer to look for sprite zero at sprite page 255, you would now type POKE 53240,255 instead of POKE 2040,255. If you need further information on graphics programming you should look in the *Commodore 64 Programmer's Reference Guide*.

The new commands are really very simple to use. You can now load and save graphics displays, go to graphics mode and return. And you can clear the graphics display.

Pictures are stored in a two-file format. The first and largest file contains the bit map. The second file contains the high-res color, border color, background color, and if the picture is in multi-color it contains an extra 1K of data for color two. When you save a picture, you will save two files. The first is, of course, the bit map, and the

second contains the color information for that picture.

The commands for accessing and executing the machine language in this program are the same as those for *Simons' BASIC* and *Super Expander*, with one difference. BA is equal to 50176 for BASIC screens.

Once again, keep in mind when loading or saving that you will always be working with two files. One file will contain the bit map, and one will contain color information. If you wish to save the bit map, remember that the first parameter after the address is zero (SYS BA + 3,0, "filename",8). If you wish to save high-res color with the bit map, first use the bit-map save and then use the parameter one to save color. (SYS BA + 3,1, "filename.hr",8). To save a multi-color picture, first save the bit

map with a parameter of one, and then save again using the parameter two (SYS BA + 3,2, "filename.mc",8). When loading, simply load both files. And it is a good practice when saving pictures to use the suffixes .hr for a high-res color file and .mc for a multi-color color file. Those are the conventions used by Chameleon, and will help you to keep your pictures straight.

It is also necessary to use a GOTO graphics mode command after loading a picture, as this transfers the color memories to their correct locations.

If you use these commands in conjunction with Chameleon, you can now have almost unlimited graphics in your own BASIC program. And best of all, you haven't lost a byte of BASIC memory! **C**

Before typing this program read "How to Enter Programs".

Chameleon II: Machine Language

```
10 REM CHAMELEON MACHINE LANGUAGE'BYIE
20 FOR Z=49152 TO 50014:READ Y:I=I+Y
   :POKE Z,Y:NEXT' IWEI
```

```
30 DATA 162,2,32,198,255,234,234,
   234'BDOE
40 DATA 234,234,234,32,125,192,32,
   207'BEZG
50 DATA 255,160,0,145,251,32,183,
   255'BDHG
```

Continued next page

SOURCE PHONEMARK FOR COST-EFFECTIVE COMPUTER DATA STORAGE

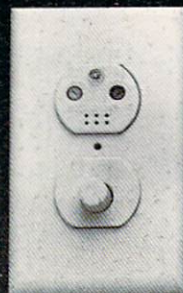

Model:
PM-6601 AUDIO LIGHT:
A safe, convenient and energy-saving light switch activated by sound.
Your light ON AND OFF without your touching it.



Model 8500 QUICK DATA DRIVE:
A High speed reliability. Mass storage drive. Fully computer-controlled operation, with 15 times fast than Audio cassette compatible with COMMODORE VIC-20, COMMODORE 64, and 128 computers.

DISTRIBUTORS INQUIRIES WELCOME



PM-C16

CASSETTE MODEL:
PM-4401C, PM-4402C,
PM-C16 compatible with Commodore Computers VIC-20, 64, PLUS-4, C16, 128.

PHONEMARK ELECTRONICS CO., LTD.

No. 5, Lane 220, Chung Yung N. Rd., Sec. 3, Beitou (112), Taipei, Taiwan, R.O.C. Telex: 26162 PHOMARK Cable: "PHOMARK" Taipei Tel: (02) 894-5511, 895-1212, 895-1213, 895-1214

64 USERS ONLY

60 DATA 208,31,230,251,208,2,230, 252'BDTH	400 DATA 141,0,221,173,17,208,9, 32'BABD
70 DATA 238,172,192,208,3,238,173, 192'BERJ	410 DATA 141,17,208,173,24,208,41, 15'BCFE
80 DATA 173,172,192,205,170,192,208, 222'BGFK	420 DATA 9,48,41,240,9,8,141,24'BWUE
90 DATA 173,173,192,205,171,192,208, 214'BGIL	430 DATA 208,173,17,208,9,16,141, 17'BBOG
100 DATA 96,76,204,255,162,2,32, 201'BBKA	440 DATA 208,96,162,5,142,193,193, 32'BCUH
110 DATA 255,32,125,192,165,1,41, 254'BCJB	450 DATA 253,174,32,158,173,32,247, 183'BEPJ
120 DATA 133,1,160,0,177,251,32, 210'BBQC	460 DATA 174,193,193,165,21,149,249, 202'BFRK
130 DATA 255,230,251,208,2,230,252, 238'BEXE	470 DATA 165,20,149,249,202,142,193, 193'BFLL
140 DATA 172,192,208,3,238,173,192, 173'BEPF	480 DATA 224,255,208,227,165,2,240, 8'BCML
150 DATA 172,192,205,170,192,208,227, 173'BGKG	490 DATA 165,1,41,254,133,1,208, 14'BAYM
160 DATA 173,192,205,171,192,208,219, 165'BGOH	500 DATA 173,14,220,41,254,141,14, 220'BDRE
170 DATA 1,9,1,133,1,96,234,234'BWLG	510 DATA 165,1,41,252,133,1,160,0'BYRF
180 DATA 234,234,234,234,234,32,253, 174'BFDJ	520 DATA 177,253,145,249,165,253,197, 251'BGBH
190 DATA 32,158,173,32,247,183,165, 20'BDPJ	530 DATA 208,6,165,254,197,252,240, 15'BDSH
200 DATA 133,251,165,21,133,252,32, 253'BEUC	540 DATA 230,253,208,2,230,254,230, 249'BEWJ
210 DATA 174,32,158,173,32,247,183, 165'BERD	550 DATA 208,230,230,250,24,144,225, 165'BFTK
220 DATA 20,141,170,192,165,21,141, 171'BERE	560 DATA 2,240,7,165,1,9,1,133'BVGJ
230 DATA 192,169,0,141,172,192,141, 173'BEGF	570 DATA 1,96,165,1,9,3,133,1'BUMK
240 DATA 192,96,234,234,234,234,234, 234'BFMG	580 DATA 173,14,220,9,1,141,14, 220'BARM
250 DATA 173,17,208,41,239,141,17, 208'BDNG	590 DATA 96,234,234,234,234,234,234, 234'BFJO
260 DATA 173,22,208,41,239,141,22, 208'BDFH	600 DATA 234,234,234,234,234,234,234, 234'BGBG
270 DATA 24,144,8,173,17,208,41, 239'BBQI	610 DATA 169,0,133,158,169,204,133, 159'BEOH
280 DATA 141,17,208,173,2,221,9,3'BYDJ	620 DATA 160,0,177,158,170,189,232, 207'BELI
290 DATA 141,2,221,173,0,221,41, 252'BBNK	630 DATA 145,158,230,158,208,2,230, 159'BEIJ
300 DATA 9,3,141,0,221,173,17,208'BYBC	640 DATA 165,158,201,232,208,234,165, 159'BGLK
310 DATA 41,223,141,17,208,173,24, 208'BDED	650 DATA 201,207,208,228,96,234,234, 234'BFHL
320 DATA 41,15,9,16,41,240,9,4'BVMD	660 DATA 234,234,234,234,234,234,234, 234'BGBM
330 DATA 141,24,208,173,17,208,9, 16'BBMF	670 DATA 32,253,174,32,158,173,32, 130'BDHM
340 DATA 141,17,208,96,234,234,234, 234'BEIH	680 DATA 183,166,34,164,35,201,0, 208'BCHN
350 DATA 173,17,208,41,239,141,17, 208'BDNH	690 DATA 47,165,186,32,180,255,169, 111'BEQP
360 DATA 173,22,208,9,16,141,22, 208'BBGI	700 DATA 133,185,32,150,255,32,165, 255'BEGH
370 DATA 24,144,8,173,17,208,41, 239'BBQJ	710 DATA 72,32,210,255,32,165,255, 72'BCKH
380 DATA 141,17,208,173,2,221,9,3'BYDK	720 DATA 32,210,255,32,165,255,32, 210'BDXI
390 DATA 141,2,221,173,0,221,41, 252'BBNL	730 DATA 255,201,13,208,246,32,171,

64 USERS ONLY

```
255'BEAK
740 DATA 104,168,104,170,169,0,240,
50'BDBK
750 DATA 134,251,132,252,141,216,194,
160'BGVM
760 DATA 0,177,251,201,36,240,37,
165'BCGM
770 DATA 186,32,177,255,169,111,133,
185'BFSO
780 DATA 32,147,255,160,0,177,251,
32'BCHO
790 DATA 168,255,200,204,216,194,208,
245'BGIQ
800 DATA 169,13,32,168,255,32,174,
255'BDWH
810 DATA 169,0,240,99,169,8,170,
160'BBYI
820 DATA 0,32,186,255,173,216,194,
166'BDUJ
830 DATA 251,164,252,32,189,255,32,
192'BENL
840 DATA 255,169,0,32,13,194,192,
48'BBUL
850 DATA 208,61,162,8,32,198,255,
32'BBTM
860 DATA 207,255,32,207,255,32,207,
255'BEGO
870 DATA 32,207,255,240,42,32,207,
255'BDFO
880 DATA 72,32,207,255,168,104,170,
152'BEEQ
890 DATA 32,205,189,169,32,32,210,
255'BDMQ
900 DATA 32,207,255,72,173,141,2,
208'BCHI
910 DATA 251,104,208,241,169,13,32,
210'BERK
920 DATA 255,165,145,201,127,208,206,
32'BFBL
930 DATA 204,255,169,8,32,195,255,
96'BCHL
940 DATA 0,234,234,234,234,234,234,
234'BEWN
950 DATA 234,234,234,234,234,234,234,
234'BGBO
960 DATA 234,234,234,234,234,234,234,
234'BGBP
970 DATA 234,234,234,234,234,234,234,
234'BGBQ
980 DATA 234,234,234,234,234,234,234,
234'BGBR
990 DATA 162,5,142,90,195,32,253,
174'BCPR
1000 DATA 32,158,173,32,247,183,174,
90'BDWX
1010 DATA 195,165,21,149,249,202,165,
20'BEKA
1020 DATA 149,249,202,142,90,195,224,
255'BFPB
1030 DATA 208,227,173,14,220,41,254,
141'BEWC
1040 DATA 14,220,165,1,41,252,133,
1'BAQC
1050 DATA 160,0,165,249,145,253,165,
253'BEJE
1060 DATA 197,251,208,6,165,254,197,
252'BEXF
1070 DATA 240,9,230,253,208,236,230,
254'BEAG
1080 DATA 24,144,231,165,1,9,3,
133'BYCG
1090 DATA 1,173,14,220,9,1,141,14'BXYG
1100 DATA 220,96,0,234,255,0,255'BWPX
1110 IF I<>129373 THEN PRINT"YOU HAVE
A DATA ERROR. PLEASE CHECK DATA"
:END'GIJK
1120 PRINT"THE MACHINE LANGUAGE
[SPACE2]FOR[SPACE2]
CHAMELEON IS NOW INSTALLED."
:END'CBNL
```

END

Program 1. Chameleon BASIC

```
30 POKE 53280,0:POKE 53281,0
:POKE 646,14:PRINT" [CLEAR]
"CHR$(8)CHR$(14):RESTORE'HGHC
40 SP$="[SPACE39]"'BDNG
50 C=1:NC=4:EC=8:HP=10:MP=9:HR=1:PV=0
:AR=0:POKE 808,234'JOKQ
60 DIM CX(NC),CY(NC),CM$(NC),HP$(HP),
MI$(20),MP$(MP),EX$(3),AR$(1)'BJMP
70 EX$(1)=".HR":EX$(2)=".MC"
:EX$(3)=".GP"'DUTL
80 AR$(0)="OFF":AR$(1)="ON"'CNVJ
90 CM$="[BLUE,SHFT C,SHFT O,SHFT M2,
SHFT A,SHFT N,SHFT D,SHFT S]
:[L.BLUE,SPACE2,SHFT D]ISPLAY
[SPACE2,SHFT Q]UIT[SPACE2,SHFT R]
EAD[SPACE2,SHFT W]RITE"'BDWA
100 FOR T=1 TO NC:READ CY(T),CX(T),
CM$(T):NEXT'FYFD
110 DATA 22,11,"[SHFT D]ISPLAY",22,20,
"[SHFT Q]UIT",22,26,"[SHFT R]EAD",
22,32,"[SHFT W]RITE"'BCFJ
120 FOR T=0 TO HP:READ A$
:HP$(T)=A$+LEFT$(SP$,20-LEN(A$))
:NEXT'KETJ
130 DATA "[SHFT C]ADPAK","[SHFT D]
OODLE","[SHFT F]LEXIDRAW","
[SHFT G]RAPHICS [SHFT B]ASIC","
[SHFT L]OGO"'BESN
140 DATA "[SHFT S]IMONS' [SHFT B]
ASIC","[SHFT S]UPER [SHFT E]
XPANDER","[SHFT T]HE [SHFT T]OOL",
"[SHFT V]IDEO [SHFT B]ASIC"'BDPQ
150 DATA "[SHFT C]-64 [SHFT S]
TANDARD [SHFT S]CREEN","[SHFT R]
ETURN TO [SHFT M]AIN [SHFT M]
ENU"'BBGO
160 FOR T=0 TO MP:READ A$
:MP$(T)=A$+LEFT$(SP$,20-LEN(A$))
:NEXT'KEEN
170 DATA "[SHFT B]LAZING [SHFT P]
ADDLES","[SHFT G]RAPHICS [SHFT B]
ASIC","[SHFT K]OALA","[SHFT M]
ICRO [SHFT I]LLUSTRATOR"'BDVV
180 DATA "[SHFT P]ERIPHERAL [SHFT V]
```

64 USERS ONLY

```

ISION", "[SHFT S]IMONS' [SHFT B]
ASIC", "[SHFT S]UPER [SHFT E]
XPANDER" 'BCLT
190 DATA "[SHFT V]IDEO [SHFT B]ASIC",
"[SHFT C]-64 [SHFT S]TANDARD
[SHFT S]CREEN", "[SHFT R]ETURN TO
[SHFT M]AIN [SHFT M]ENU" 'BCDW
200 FOR T=1 TO 20:READ A
:MIS(T)=CHR$(A):NEXT HRGE
210 DATA 255,128,105,103,20,0,1,232,3,
232,3,64,31,1,0,40,0,200,0,0'BHBI
220 RESTORE:REM SET UP VERIFY'CMLC
230 GOSUB 240:GOTO 300'CHUB
240 PRINT"[CLEAR,BLUE,CMDR A,SHFT *38,
CMDR S]";'BBPG
250 PRINT"[SHFT -,YELLOW,SPACE14,
SHFT C]HAMELEON[SPACE15,BLUE,
SHFT -]";'BBDL
260 PRINT"[SHFT -,L. RED] [SHFT B]Y
[SHFT D]AVID [SHFT D]ARUS &
[SHFT L]OUIS [SHFT W]
ALLACE @1985 [BLUE,SHFT -]";'BBOR
270 PRINT"[CMDR Z,SHFT *38,CMDR X]";
'BBEI
280 X=0:Y=21:GOSUB 1410'DLKI
290 PRINT"[SHFT *40]";:RETURN'CCUL
300 PRINT CM$;'BEKX
310 REM GET COMMANDS'BLRB
320 C=1'BCMA
330 X=CX(C):Y=CY(C):GOSUB 1410
:PRINT"[RVS,WHITE]"CM$(C)"[RVOFF]
";:POKE 198,0'FHKL
340 GET A$:IF A$=""THEN 340'EIGF
350 X=CX(C):Y=CY(C):GOSUB 1410
:PRINT"[L. BLUE]"CM$(C);'EBSL
360 IF A$=CHR$(13)THEN 530'EJRH
370 IF A$="[RIGHT]"THEN 480'DFCH
380 IF A$="[LEFT]"THEN 510'DFYI
390 IF A$="D"THEN C=1:GOTO 530'FIPL
400 IF A$="Q"THEN C=2:GOTO 530'FIDD
410 IF A$="R"THEN C=3:GOTO 530'FIFE
420 IF A$="W"THEN C=4:GOTO 530'FILF
430 IF A$="[CYAN]"THEN GOSUB 3170
:GOTO 230'FKCG
440 IF A$="[BLACK]"THEN GOSUB 3150
:GOTO 230'FKKH
450 IF A$="[F2]"THEN GOSUB 3180'EGSH
460 GOTO 330'BDFB
470 REM CURSOR RIGHT'BLJI
480 C=C+1:IF C>NC THEN C=1'GJQM
490 GOTO 330'BDFI
500 REM CURSOR LEFT'BKBC
510 C=C-1:IF C<1 THEN C=NC'GJTG
520 GOTO 330'BDFC
530 ON C GOTO 550,720,740,880
:GOTO 340'DUSH
540 REM DISPLAY'BHOF
550 POKE 53265,PEEK(53265)AND 239'DQJT
560 IF HR=1 THEN SYS 49427:GOTO 590
:REM TURN ON HIRES'GYAO
570 POKE 2,1:SYS 49482,51200,52199,
55296:POKE 2,0:REM XFER IN COLOR
MEMORY'EYET
580 SYS 49408:REM MC ON'CKGK
590 BD=PEEK(51198)AND 15
:BG=PEEK(51199)AND 15
:POKE 53280,BD:POKE 53281,BG'IQCW
600 GET A$:IF A$=""THEN 600'EIFE
610 IF A$=CHR$(13)THEN 670
:REM EXIT'FOAH
620 IF A$="[F3]"THEN POKE 53280,BD
:POKE 51198,BD:BD=BD+1
:IF BD>15 THEN BD=0'LIIQ
630 IF A$="[F5]"THEN POKE 53281,BG
:POKE 51199,BG:BG=BG+1
:IF BG>15 THEN BG=0'LIER
640 IF A$<>"[CLEAR]"THEN 600
:REM CLEAR BITMAP'FRSM
650 SYS 49920,57344,65535,0
:SYS 49920,51198,53247,0'COKO
660 POKE 2,1:SYS 49482,51200,52199,
55296:POKE 2,0:GOTO 600'EKGP
670 POKE 53280,0:POKE 53281,0'CPLL
680 POKE 53265,PEEK(53265)AND 239
:PRINT"[CLEAR]":IF HR=1 THEN SYS
49347:GOTO 700'JFCU
690 SYS 49328:REM TURN OFF
MULTICOLOR'CXIQ
700 PRINT CHR$(8);CHR$(14)
:GOTO 230'EMXF
710 REM QUIT'BEJD
720 PRINT"[CLEAR,L. BLUE]":END'CBEF
730 REM READ'BEUF
740 X=0:Y=24:GOSUB 1410
:PRINT"[GRAY2,RVS,SHFT H,RVOFF]
IRES[SPACE2,RVS,SHFT M,RVOFF]
ULTICOLOR[WHITE]";:POKE 51198,
0'FVMU
750 X=18:Y=24:L=1:GOSUB 1440'EPXM
760 IF AN$="H"OR AN$="[SHFT H]
"THEN GOSUB 1080:P=Y-7
:GOTO 800'JSER
770 IF AN$="M"OR AN$="[SHFT M]
"THEN GOSUB 1240:P=Y-7
:GOTO 840'JSQS
780 IF AN$="*"THEN 230'DGLM
790 GOTO 750'BDLL
800 IF P>10 THEN 230'DGPF
810 GOSUB 1600:IF P=4 OR P=8 THEN
830'GMWJ
820 GOSUB 1660:IF OK=1 THEN 230'ELPI
830 ON P GOTO 1720,1740,1760,1840,
1870,1890,1930,1950,1980,2010'CAYP
840 IF P>9 THEN 230'DFBJ
850 GOSUB 1600:IF P<>2 THEN GOSUB 1660
:IF OK=1 THEN 230'JSAQ
860 ON P GOTO 2050,2080,2120,2150,
2180,2230,2280,2300,2340'CUJR
870 REM WRITE'BFAL
880 X=0:Y=24:GOSUB 1410
:PRINT"[GRAY2,RVS,SHFT H,RVOFF]
IRES[SPACE2,RVS,SHFT M,RVOFF]
ULTICOLOR[WHITE]";'ENJX
890 X=18:Y=24:L=1:GOSUB 1440'EPXR
900 IF AN$="H"OR AN$="[SHFT H]

```

64 USERS ONLY

```

"THEN GOSUB 1080:P=Y-7
:GOTO 940'JSJN
910 IF AN$="M"OR AN$="[SHFT M]
"THEN GOSUB 1240:P=Y-7
:GOTO 980'JSVO
920 IF AN$="*"THEN 230'DGLI
930 GOTO 890'BDQH
940 IF P>10 THEN 230'DGPK
950 GOSUB 1600:IF P=4 OR P=8 THEN
970'GMCO
960 GOSUB 1660:IF OK=1 THEN 230'ELPN
970 ON P GOTO 2390,2410,2430,2450,
2490,2510,2570,2590,2630,2650'CAKU
980 IF P>9 THEN 230'DFBO
990 GOSUB 1600:IF P<>2 THEN GOSUB 1660
:IF OK=1 THEN 230'JSAV
1000 ON P GOTO 2710,2750,2790,2820,
2860,2930,3010,3030,3100'CUKC
1010 SYS 49209:CLOSE 2:CLOSE 1
:RETURN'EKHX
1020 LB=0'BDLV
1030 PRINT#2,CHR$(LB);:PRINT#2,
CHR$(HB);'EPCB
1040 POKE 2,0:SYS 49482,57344,65535,
40960:RETURN'DDBE
1050 AN$=LEFT$(AN$,13)+EX$(TP)'DSHE
1060 Y=20:X=16:GOSUB 1410
:PRINT"[YELLOW]"AN$+LEFT$(SP$,
16-LEN(AN$))"[L. BLUE]";'IFVM
1065 GOSUB 1660:RETURN'CFIG
1070 REM HIRES PACKAGES'BNWE
1080 GOSUB 240:X=11:Y=5:GOSUB 1410
:PRINT"[PURPLE,SHFT H]IRES
[SHFT P]ACKAGE [SHFT M]ENU"'FQVO
1090 X=11:Y=6:GOSUB 1410
:PRINT"[GREEN,SHFT *18]"'EMVU
1100 GOSUB 1630:HR=1:X=9:Y=7
:GOSUB 1410:PRINT"[YELLOW,CMDR A,
SHFT *20,CMDR S]"'GUVT
1110 FOR T=0 TO HP:Y=T+8:X=9
:GOSUB 1410:PRINT"[YELLOW,SHFT -,
ORANGE]"HP$(T)"[YELLOW,SHFT -]"
:NEXT'JYJCJ
1120 Y=19:GOSUB 1410:PRINT"[CMDR Z,
SHFT *20,CMDR X,ORANGE]":Y=8:X=10
:GOTO 1220'GVDV
1130 GET A$:IF A$=""THEN 1130'EJCB
1140 GOSUB 1410:PRINT HP$(Y-8);'DNTE
1150 IF A$="[DOWN]"THEN Y=Y+1
:IF Y>18 THEN Y=8'JLLH
1160 IF A$="[UP]"THEN Y=Y-1
:IF Y<8 THEN Y=18'JLMJ
1170 IF A$="[CYAN]"THEN GOSUB 3170
:GOTO 1080'FLEG
1180 IF A$="[BLACK]"THEN GOSUB 3150
:GOTO 1080'FLMH
1190 IF A$="[F2]"THEN TP=Y:GOSUB 3180
:Y=TP:X=10'HSMH
1200 IF A$="*"THEN 230'DFJX
1210 IF A$=CHR$(13)THEN GOSUB 1410
:PRINT"[RVS,CYAN]"HP$(Y-8)"
[RVOFF]";:RETURN'IUXG
1220 GOSUB 1410:PRINT"[ORANGE,RVS]
"HP$(Y-8)"[RVOFF]";
:GOTO 1130'ESNE
1230 REM MULTICOLOR PACKAGES'BSPD
1240 GOSUB 240:X=8:Y=5:GOSUB 1410
:PRINT"[PURPLE,SHFT M]ULTICOLOR
[SHFT P]ACKAGE [SHFT M]ENU"'FPWO
1250 X=8:Y=6:GOSUB 1410
:PRINT"[GREEN,SHFT *23]"'ELUW
1260 GOSUB 1630:HR=0:X=9:Y=7
:GOSUB 1410:PRINT"[YELLOW,CMDR A,
SHFT *20,CMDR S]"'GUUB
1270 FOR T=0 TO MP:Y=T+8:X=9
:GOSUB 1410:PRINT"[YELLOW,SHFT -,
ORANGE]"MP$(T)"[YELLOW,SHFT -]"
:NEXT'JYMQ
1280 Y=18:GOSUB 1410:PRINT"[CMDR Z,
SHFT *20,CMDR X,ORANGE]":Y=8:X=10
:GOTO 1380'GVJD
1290 GET A$:IF A$=""THEN 1290'EJJI
1300 GOSUB 1410:PRINT MP$(Y-8);'DNYA
1310 IF A$="[DOWN]"THEN Y=Y+1
:IF Y>17 THEN Y=8'JLKF
1320 IF A$="[UP]"THEN Y=Y-1
:IF Y<8 THEN Y=17'JLLH
1330 IF A$="[CYAN]"THEN GOSUB 3170
:GOTO 1240'FLCE
1340 IF A$="[BLACK]"THEN GOSUB 3150
:GOTO 1240'FLKF
1350 IF A$="[F2]"THEN TP=Y:GOSUB 3180
:Y=TP:X=10'HSMK
1360 IF A$="*"THEN 230'DFJF
1370 IF A$=CHR$(13)THEN GOSUB 1410
:PRINT"[RVS,CYAN]"MP$(Y-8)"
[RVOFF]";:RETURN'IUDN
1380 GOSUB 1410:PRINT"[ORANGE,RVS]
"MP$(Y-8)"[RVOFF]";
:GOTO 1290'ESAL
1390 RETURN'BAQF
1400 REM CURSOR PLOT'BKVA
1410 POKE 781,Y:POKE 782,X:POKE 783,0
:SYS 65520:RETURN'FYJG
1420 REM FIELD EDITOR'BLKC
1430 REM PASS X,Y,L=LENGTH RETURNS
AN$'BBAI
1440 AN$="":GOSUB 1410:PRINT"[RVS]
"LEFT$(SP$,L)"[RVOFF]";
:GOSUB 1410:POKE 204,0'GDBL
1450 POKE 204,0'BFLD
1460 GET A$:POKE 207,0:IF A$=""THEN
1460'FPAJ
1470 POKE 204,1:A=ASC(A$)'DLAI
1480 IF A<13 THEN 1500'EHBH
1490 GOSUB 1410:PRINT AN$;LEFT$(SP$,
(L+1)-LEN(AN$));:RETURN'HBNQ
1500 IF A=20 AND LEN(AN$)>0 THEN
GOSUB 1570'HNFH
1510 IF A=147 AND LEN(AN$)>0 THEN
GOSUB 1570:GOTO 1440'ITDH
1520 IF A=92 THEN 1550'DHPD
1530 IF A<31 OR A>218 THEN 1450'FLTG
1540 IF A>90 AND A<193 THEN 1450'FLAH
1550 IF LEN(AN$)>=L THEN 1450'FKNI
1560 PRINT A$;:AN$=AN$+A$

```

64 USERS ONLY

```

:GOTO 1450'ERNK
1570 A$="[RVS] [RVOFF,LEFT]"
      :IF LEN(AN$)>=L THEN A$=" [LEFT]
      "'HLXO
1580 PRINT A$;"[LEFT,RVS] [RVOFF,LEFT]
      ";;AN$=LEFT$(AN$,LEN(AN$)-1)
      :RETURN'GVSQ
1590 REM FILENAME'BIHJ
1600 X=0:Y=20:GOSUB 1410
      :IF C=3 THEN PRINT"[L. BLUE]
      [SHFT R]EAD FILENAME
      :[YELLOW]"'HOGM
1610 IF C=4 THEN PRINT"[L. BLUE,
      SHFT W]RITE FILENAME
      :[YELLOW]"'ECAI
1620 X=16:Y=20:L=16:GOSUB 1440
      :RETURN'FRPI
1630 X=0:Y=22:GOSUB 1410
      :PRINT"[PURPLE,SHFT C]
      URSOR KEYS MOVE HIGHLIGHTER
      [SPACE10]";'ENLR
1640 X=0:Y=23:GOSUB 1410
      :PRINT"[SHFT P]RESS [RVS,SHFT R,
      SHFT E,SHFT T,SHFT U,SHFT R,
      SHFT N,RVOFF] TO MAKE SELECTION";
      :RETURN'FORV
1650 REM OPEN FILE'BIYG
1660 IF LEN(AN$)=0 THEN OK=1
      :RETURN'GKGL
1670 IF LEFT$(AN$,1)="*"THEN AN$="
      [ORANGE]" +MID$(AN$,2,13)
      :SS=1'IYVR
1675 IF SS=1 THEN SS=0:AN$=AN$+LEFT$(
      (SP$,15-LEN(AN$))'JBXJ
1680 OPEN 1,8,15,"I":ZZ$=" ,P,R"
      :IF C=4 THEN ZZ$=" ,P,W"'GRGR
1690 OPEN 2,8,2,AN$+ZZ$
      :GOSUB 3220'DREN
1700 IF C=3 AND OK=0 THEN GET#2,A$
      :GET#2,A$'HQEH
1710 RETURN'BAQB
1720 REM CADPAK *READ SECTION*'BTIH
1730 SYS 49152,57344,8192
      :SYS 49163,52224,1024:GOSUB 1010
      :GOTO 230'EREN
1740 REM DOODLE'BGTT
1750 SYS 49152,52224,1024
      :SYS 49163,57344,8000:GOSUB 1010
      :GOTO 230'ERRP
1760 REM FLEXIDRAW'BJCJ
1770 SYS 49152,57344,8000:GOSUB 1010
      :NF$=AN$:X=0:Y=24:GOSUB 1410'GPKT
1780 PRINT"[SHFT D]O YOU WANT TO LOAD
      COLOR (Y/N)[SPACE7]";'BBNS
1790 X=32:Y=24:L=1:GOSUB 1440
      :IF AN$="N"OR AN$=" "[SHFT N]
      "THEN 1830'JBBV
1800 IF AN$<>"Y"AND AN$<>" "[SHFT Y]
      "THEN 1790'HKUJ
1810 TP=3:PV=1:GOSUB 1050
      :IF OK=1 THEN 230'GTKL
1820 SYS 49152,52224,1024:GOSUB 1010
      :SYS 49616:REM COLOR'EIPM
1830 GOTO 230'BDEF
1840 REM GRAPHICS BASIC'BNPJ
1850 OPEN 1,8,15:OPEN 2,8,2,AN$+" ,S,R"
      :GOSUB 3210:IF OK=1 THEN 230'HDOR
1860 GET#2,A$:SYS 49152,57344,8000
      :SYS 49163,52223,1001:GOSUB 1010
      :GOTO 230'FXXT
1870 REM LOGO'BEQJ
1880 SYS 49152,57344,8192:GOSUB 1010
      :GOTO 230'DAHP
1890 REM SIMONS' BASIC'BMPN
1900 SYS 49152,57344,8000:GOSUB 1010
      :TP=1:PV=1:GOSUB 1050
      :IF OK=1 THEN 230'IQAP
1910 SYS 49152,52224,1002:GOSUB 1010
      :POKE 51198,PEEK(53224)'EKSM
1915 POKE 51199,PEEK(53225)'CNXL
1920 GOTO 230'BDEF
1930 REM SUPER EXPANDER'BNQJ
1940 GOTO 1900'BEHH
1950 REM THE TOOL'BHXJ
1960 OPEN 1,8,15:OPEN 2,8,2,AN$+" ,P,R"
      :GOSUB 3210:IF OK=1 THEN 230'HDLT
1970 GET#2,A$:SYS 49152,52224,1024
      :SYS 49163,57344,8192:GOSUB 1010
      :GOTO 230'FXQV
1980 REM VIDEO BASIC'BKDN
1990 SYS 49152,57344,8192
      :IF ST=0 THEN SYS 49163,52224,
      1024'FLQV
2000 GOSUB 1010:GOTO 230'CIQV
2010 REM STANDARD'BIXW
2020 SYS 49152,57344,8000:GOSUB 1010
      :TP=1:PV=1:GOSUB 1050
      :IF OK=1 THEN 230'IQAJ
2030 SYS 49152,52222,1002:GOSUB 1010
      :POKE 51198,PEEK(52222)'EKNG
2035 POKE 51199,PEEK(52223)'CNUF
2040 GOTO 230'BDEY
2050 REM BLAZING PADDLES'BOVD
2060 SYS 49152,57344,8192
      :SYS 49163,52224,1024
      :SYS 49163,51200,1024'DAAL
2070 GOSUB 1010:POKE 2,0
      :SYS 49482,65407,65408,51198
      :GOTO 230'ELEK
2080 REM GRAPHICS BASIC'BNPG
2090 OPEN 1,8,15:OPEN 2,8,2,AN$+" ,S,R"
      :GOSUB 3210:IF OK=1 THEN 230'HD00
2100 GET#2,A$:SYS 49152,57344,8000
      :SYS 49163,52223,1001
      :SYS 49163,51199,1001'EGGI
2110 GOSUB 1010:GOTO 230'CIQX
2120 REM KOALA'BFXV
2130 SYS 49152,57344,8000
      :SYS 49163,52224,1000
      :SYS 49163,51200,1001'DACJ
2140 POKE 51199,PEEK(52200):GOSUB 1010
      :GOTO 230'EWJF
2150 REM MICRO ILLUSTRATOR'BQJF
2160 SYS 49152,50000,20
      :SYS 49163,52224,1000
      :SYS 49163,51200,1000'DXGM

```

64 USERS ONLY

```
2170 POKE 51199,PEEK(50006)
      :SYS 49163,57344,8000:GOSUB 1010
      :GOTO 230'FORM
2180 REM PERIPHERAL VISION'BQHI
2190 SYS 49152,52224,1024
      :SYS 49163,57344,8000
      :GOSUB 1010'DNEN
2200 AN$=LEFT$(AN$,LEN(AN$)-4)
      +".CMM"'FPMD
2205 IF LEFT$(AN$,1)="[POUND]
      "THEN AN$=MID$(AN$,2)'GRAI
2210 PV=1:GOSUB 1060:IF OK=1 THEN
      230'FPXD
2220 SYS 49152,51200,1000:POKE 51199,1
      :GOSUB 1010:GOTO 230'EIDG
2230 REM SIMONS' BASIC'BMPC
2240 SYS 49152,57344,8000:GOSUB 1010
      :NF$=AN$:TP=1:PV=1'FLUL
2245 GOSUB 1050:IF OK=1 THEN 230'ELIJ
2250 SYS 49152,52224,1002:GOSUB 1010
      :POKE 51198,PEEK(53224)'EKSK
2255 POKE 51199,PEEK(53225)'CNXJ
2260 TP=2:PV=1:AN$=NF$:GOSUB 1050
      :IF OK=1 THEN 230'HBWM
2270 SYS 49152,51200,1000:GOSUB 1010
      :GOTO 230'DAXJ
2280 REM SUPER EXPANDER'BNQI
2290 GOTO 2240'BEFG
2300 REM VIDEO BASIC'BKDA
2310 SYS 49152,57344,8192
      :SYS 49163,52224,1024
      :SYS 49163,50000,48'DXGJ
2320 SYS 49163,51200,1024
      :POKE 51198,PEEK(50032)
      :POKE 51199,PEEK(50033)'FTAK
2330 GOSUB 1010:GOTO 230'CIQC
2340 REM STANDARD'BIXD
2350 SYS 49152,57344,8000:GOSUB 1010
      :TP=2:PV=1:GOSUB 1050
      :IF OK=1 THEN 230'IQBP
2360 SYS 49152,51200,2024:GOSUB 1010
      :POKE 51198,PEEK(52222)'EKNM
2365 POKE 51199,PEEK(52223)'CNUL
2370 GOTO 230'BDEF
2380 REM WRITE'BFAH
2390 REM CADPAK'BGAI
2400 HB=160:GOSUB 1020:SYS 49212,
      40960,8192'DCBF
2405 SYS 49217,52224,1024:GOSUB 1010
      :GOTO 230'DANJ
2410 REM DOODLE'BGTB
2420 HB=92:GOSUB 1020:SYS 49212,52224,
      1024'DBPH
2425 SYS 49217,40960,8000:GOSUB 1010
      :GOTO 230'DASL
2430 REM FLEXIDRAW'BJCE
2440 HB=32:GOSUB 1020:SYS 49212,40960,
      8000:GOSUB 1010:GOTO 230'FKJM
2450 REM GRAPHICS BASIC'BNPH
2460 OPEN 1,8,15:OPEN 2,8,2,AN$+" ,S,W"
      :GOSUB 3210:IF OK=1 THEN 230'HDTP
2470 PRINT#2,CHR$(72);:GOSUB 1040
      :SYS 49212,40960,8000'EEIN
2480 SYS 49217,52223,1001:GOSUB 1010
      :GOTO 230'DAHM
2490 REM LOGO'BEQI
2500 HB=32:GOSUB 1020:SYS 49212,40960,
      8192:GOSUB 1010:GOTO 230'FKVJ
2510 REM SIMONS' BASIC'BMPD
2520 HB=224:CR=192'CLPE
2530 GOSUB 1020:SYS 49212,40960,8000
      :GOSUB 1010:TP=1:PV=1'FJOM
2535 GOSUB 1050:IF OK=1 THEN 230'ELIL
2540 POKE 53224,PEEK(51198)
      :POKE 53225,PEEK(51199)'ECWK
2550 PRINT#2,CHR$(0);:PRINT#2,
      CHR$(CR);'EOTJ
2560 SYS 49212,52224,1002:GOSUB 1010
      :GOTO 230'DAEL
2570 REM SUPER EXPANDER'BNQK
2580 HB=160:CR=124:GOTO 2530'DQTM
2590 REM THE TOOL'BHXX
2600 OPEN 1,8,15:OPEN 2,8,2,AN$+" ,P,W"
      :GOSUB 3210:IF OK=1 THEN 230'HDQL
2610 PRINT#2,CHR$(71);'CHBD
2620 SYS 49212,52224,1024:GOSUB 1040
      :SYS 49217,40960,8192:GOSUB 1010
      :GOTO 230'FWGO
2630 REM VIDEO BASIC'BKDG
2640 HB=160:GOSUB 1020:SYS 49212,
      40960,8192'DCBL
2645 SYS 49217,52224,1024:GOSUB 1010
      :GOTO 230'DANP
2650 REM STANDARD'BIXH
2660 HB=224:GOSUB 1020:SYS 49212,
      40960,8000'DCPN
2670 GOSUB 1010:TP=1:PV=1
      :GOSUB 1050'ERUN
2680 IF OK=1 THEN 230'DGRL
2690 POKE 52222,PEEK(51198)
      :POKE 52223,PEEK(51199)'ECQQ
2700 PRINT#2,CHR$(254);
      :PRINT#2,CHR$(203);'ERBG
2705 SYS 49212,52222,1002:GOSUB 1010
      :GOTO 230'DACM
2710 REM BLAZING PADDLES'BOVG
2720 POKE 65407,PEEK(51198)
      :POKE 65408,PEEK(51199):HB=160
      :GOSUB 1020'GNEO
2730 SYS 49212,40960,8192
      :SYS 49217,52224,1024
      :SYS 49217,51200,1024
      :GOSUB 1010'EFYR
2740 GOTO 230'BDEG
2750 REM GRAPHICS BASIC'BNPK
2760 OPEN 1,8,15:OPEN 2,8,2,AN$+" ,S,W"
      :GOSUB 3210:IF OK=1 THEN 230'HDTS
2770 PRINT#2,CHR$(77);:GOSUB 1040
      :SYS 49212,40960,8000'EENQ
2780 SYS 49217,52223,1001
      :SYS 49217,51199,1001:GOSUB 1010
      :GOTO 230'ERJT
2790 REM KOALA'BFVL
2800 POKE 52200,PEEK(51199):HB=96
      :GOSUB 1020:SYS 49212,40960,
      8000'FPRN
```

64 USERS ONLY

```
2810 SYS 49217,52224,1000
:SYS 49217,51200,1001:GOSUB 1010
:GOTO 230'ERRN
2820 REM MICRO ILLUSTRATOR'BQJJ
2830 LB=220:HB=24:GOSUB 1030
:MI$(7)=CHR$(PEEK(51199))'GGGP
2835 FOR T=1 TO 20:PRINT#2,MI$(T);
'EOKP
2840 NEXT:SYS 49212,52224,1000
:SYS 49217,51200,1000'DJYO
2850 SYS 49217,40960,8000:GOSUB 1010
:GOTO 230'DASN
2860 REM PERIPHERAL VISION'BQHN
2870 FOR T=53224 TO 53239:POKE T,0
:NEXT'FQJP
2880 FOR T=53240 TO 53243:POKE T,110
:NEXT:FOR T=53244 TO 53247
:POKE T,111:NEXT'KMMX
2890 HB=92:GOSUB 1020:SYS 49212,52224,
1024:SYS 49217,40960,8000
:GOSUB 1010'FXEX
2900 AN$=LEFT$(AN$,LEN(AN$)-4)
+ ".CMM"'FPMK
2905 IF LEFT$(AN$,1)="[POUND]
"THEN AN$=MID$(AN$,2)'GRAP
2910 PV=1:GOSUB 1060:IF OK=1 THEN
230'FPXK
2920 PRINT#2,CHR$(0);:PRINT#2,
CHR$(192);'EPBK
2925 SYS 49212,51200,1000:GOSUB 1010
:GOTO 230'DAUQ
2930 REM SIMONS' BASIC'BMPJ
2940 HB=224:CR=192'CLPK
2950 NF$=AN$:GOSUB 1020
:SYS 49212,40960,8000:GOSUB 1010
:TP=1:PV=1:GOSUB 1050'HVLW
2960 IF OK=1 THEN 230'DGRM
2970 POKE 53224,PEEK(51198)
:POKE 53225,PEEK(51199)
:PRINT#2,CHR$(0);'GJUJ
2980 PRINT#2,CHR$(CR);:SYS 49212,
52224,1002'DYJR
2985 GOSUB 1010:TP=2:PV=1:AN$=NF$
:GOSUB 1050'FYIY
2990 IF OK=1 THEN 230'DGRP
3000 PRINT#2,CHR$(0);:PRINT#2,
CHR$(204);'EPUA
3005 SYS 49212,51200,1000:GOSUB 1010
:GOTO 230'DAUG
3010 REM SUPER EXPANDER'BNQA
3020 HB=160:CR=124:GOTO 2950'DQAC
3030 REM VIDEO BASIC'BKDB
3040 FOR T=50000 TO 50031:POKE T,0
:NEXT:FOR T=50032 TO 50046
:POKE T,240:NEXT'KKLM
3050 POKE 50047,0:POKE 50017,59
:POKE 50018,10:POKE 50019,102
:POKE 50020,20'FTFL
3060 POKE 50022,216:POKE 50024,9
:POKE 50025,113:POKE 50026,
240'EMNK
3070 POKE 50032,PEEK(51198)
:POKE 50033,PEEK(51199)'ECKJ
3080 HB=160:GOSUB 1020:SYS 49212,
40960,8192'DCBK
3085 SYS 49217,52224,1024
:SYS 49217,50000,48'CGPP
3090 SYS 49217,51200,1024:GOSUB 1010
:GOTO 230'DAGK
3100 REM STANDARD'BIXX
3110 HB=224:GOSUB 1020:SYS 49212,
40960,8000:GOSUB 1010:TP=2:PV=1
:GOSUB 1050'HUUK
3120 IF OK=1 THEN 230'DGRB
3130 POKE 52222,PEEK(51198)
:POKE 52223,PEEK(51199)'ECQG
3140 PRINT#2,CHR$(0);:PRINT#2,
CHR$(200);'EPQF
3145 SYS 49212,51200,2024:GOSUB 1010
:GOTO 230'DACL
3150 X=0:Y=20:GOSUB 1410
:PRINT"[GRAY3,SHFT D]ISK COMMAND
[L. BLUE]";:Y=24:X=0:L=38
:GOSUB 1440'IERR
3160 SYS 49664,AN$:RETURN'CKGF
3170 PRINT"[CLEAR,L. BLUE,SHFT D]
IRECTORY":SYS 49664,"$"
:GOSUB 3260:RETURN'ENYM
3180 AR=AR+1:IF AR>1 THEN AR=0'GMJL
3190 X=0:Y=24:GOSUB 1410
:PRINT"[GRAY3,SHFT A]
BORT PROMPTS "+AR$(AR)+"[SPACE2,
SHFT P]RESS SPACE";'GUCW
3200 GOSUB 3270:POKE 781,24:SYS 59903
:RETURN'ESGD
3210 REM ERROR CHECK'BKSB
3220 OK=0:INPUT#1,ER,ER$,TR,SC
:IF ER<>0 THEN 3240'GBJJ
3225 GOTO 3290'BELF
3230 RETURN'BAQA
3240 CLOSE 2:CLOSE 1:POKE 781,20
:SYS 59903:X=0:Y=20'GXQJ
3245 GOSUB 1410:PRINT ER;ER$;TR;SC;
'CSJL
3250 POKE 781,24:SYS 59903:OK=1:X=0
:Y=24:GOSUB 1410'GDOM
3260 PRINT"[GRAY3,RVS,SHFT P]
RESS SPACE TO CONTINUE.[RVOFF,
L. BLUE]";'BBLM
3270 GET A$:IF A$<>" "THEN 3270'FJNJ
3280 RETURN'BAQF
3290 POKE 781,24:SYS 59903:X=0:Y=24
:GOSUB 1410:IF PV=1 AND AR=0
THEN PV=0:GOTO 3230'MOFW
3300 PRINT"[RVS,GRAY3,SHFT P]
RESS * TO ABORT OR [SHFT F]
7 TO CONTINUE.[RVOFF]";'BBEK
3310 GET A$:IF A$=""THEN 3310'EJED
3320 IF A$="*"THEN 3350'DGMD
3330 IF A$="[F7]"THEN POKE 781,24
:SYS 59903:GOTO 3230'GTIJ
3340 GOTO 3310'BEED
3350 OK=1:CLOSE 2:IF C=4 THEN PRINT#1,
"S:"+AN$'HNEK
3360 CLOSE 1:GOTO 3230'CGQG
3370 END'BACF
```

END

64 USERS ONLY

Program 2. Simons' BASIC Save

```
10 REM SIMONS' BASIC LOAD/SAVE'BVKD
20 POKE 55,255:POKE 56,124:CLR'DOHC
30 FOR Z=32000 TO 32444:READ Y
   :POKE Z,Y:I=I+Y:NEXT'IWUJ
40 DATA 76,95,125,76,110,125,32,
   253'BCQF
50 DATA 174,32,158,173,32,247,183,
   173'BEQH
60 DATA 17,208,41,239,141,17,208,
   165'BDOH
70 DATA 20,240,11,173,22,208,9,16'BAXI
80 DATA 141,22,208,32,121,126,173,
   232'BEPK
90 DATA 195,141,32,208,173,233,195,
   141'BFHL
100 DATA 33,208,173,2,221,9,3,141'BYBA
110 DATA 2,221,173,0,221,41,252,
   141'BBNB
120 DATA 0,221,173,17,208,9,32,
   141'BABC
130 DATA 17,208,173,24,208,41,15,
   41'BBGD
140 DATA 240,9,8,141,24,208,173,
   17'BALE
150 DATA 208,9,16,141,17,208,96,
   32'BARF
160 DATA 253,174,32,212,225,169,97,
   133'BENH
170 DATA 185,169,0,76,213,255,32,
   253'BCTH
180 DATA 174,32,158,173,32,247,183,
   165'BERJ
190 DATA 20,240,63,141,102,126,173,
   32'BDRJ
200 DATA 208,141,232,195,173,33,208,
   141'BFCC
210 DATA 233,195,32,253,174,32,212,
   225'BECD
220 DATA 173,102,126,201,1,208,15,
   169'BDAD
230 DATA 0,133,253,169,192,133,254,
   162'BEFF
240 DATA 234,160,195,76,181,125,32,
   154'BEKG
250 DATA 126,169,0,133,253,169,204,
   133'BEEH
260 DATA 254,162,232,160,207,169,253,
   76'BFNI
270 DATA 216,255,32,253,174,32,158,
   173'BELJ
280 DATA 32,130,183,166,34,164,35,
   141'BDHJ
290 DATA 167,2,134,251,132,252,160,
   0'BCWK
300 DATA 177,251,153,103,126,200,204,
   167'BGVD
310 DATA 2,208,245,169,44,153,103,
   126'BDKD
320 DATA 169,80,200,153,103,126,32,
```

```
253'BEWF
330 DATA 174,32,158,173,32,247,183,
   166'BESG
340 DATA 20,169,2,160,1,32,186,
   255'BAHG
350 DATA 173,167,2,24,105,2,162,
   103'BBYH
360 DATA 160,126,32,189,255,32,192,
   255'BENJ
370 DATA 176,77,162,2,32,201,255,
   169'BCSJ
380 DATA 0,133,251,32,210,255,169,
   224'BDKAK
390 DATA 133,252,32,210,255,173,14,
   220'BEPM
400 DATA 41,254,141,14,220,165,1,
   41'BBTD
410 DATA 253,133,1,160,0,177,251,
   153'BCAE
420 DATA 187,126,200,208,248,230,252,
   165'BGGG
430 DATA 1,9,2,133,1,173,14,220'BWYF
440 DATA 9,1,141,14,220,160,0,185'BYVH
450 DATA 187,126,32,210,255,165,252,
   201'BFAJ
460 DATA 0,208,13,192,64,208,9,32'BYJJ
470 DATA 204,255,169,2,32,195,255,
   96'BCBK
480 DATA 200,208,228,24,144,183,0,
   0'BBVL
490 DATA 0,0,0,0,0,0,0,0,0'BPEK
500 DATA 0,0,0,0,0,0,0,0,0'BPEC
510 DATA 0,162,4,160,0,185,0,204'BXWE
520 DATA 153,0,216,200,208,247,238,
   127'BEZH
530 DATA 126,238,130,126,202,208,236,
   169'BGFI
540 DATA 204,141,127,126,169,216,141,
   130'BGUJ
550 DATA 126,96,162,4,160,0,185,0'BYHJ
560 DATA 216,153,0,204,200,208,247,
   238'BEVL
570 DATA 160,126,238,163,126,202,208,
   236'BGCM
580 DATA 169,216,141,160,126,169,204,
   141'BGEN
590 DATA 163,126,96,0,32'BPFL
600 IF I<>58338 THEN PRINT"YOU HAVE A
   DATA ERROR. PLEASE CHECK DATA."
   :END'GHKP
610 PRINT"THE MACHINE LANGUAGE FOR
   SIMONS' IS INSTALLED.":END'CBPO(END)
```

Program 3. Super Expander Save

```
10 REM SUPER EXPANDER LOAD/SAVE'BWRD
20 POKE 55,255:POKE 56,121:CLR'DOEC
30 FOR Z=31232 TO 31599:READ Y:I=I+Y
   :POKE Z,Y:NEXT'IWLJ
40 DATA 76,154,122,76,169,122,32,
   253'BDSF
50 DATA 174,32,158,173,32,247,183,
   173'BEQH
60 DATA 17,208,41,239,141,17,208,
```

64 USERS ONLY

```
165'BDOH
70 DATA 20,240,11,173,22,208,9,16'BAXI
80 DATA 141,22,208,32,99,122,173,
  232'BDHJ
90 DATA 127,141,32,208,173,233,127,
  141'BFWL
100 DATA 33,208,173,2,221,9,3,141'BYBA
110 DATA 2,221,173,0,221,41,252,9'BYVB
120 DATA 1,141,0,221,173,17,208,9'BYZC
130 DATA 32,141,17,208,173,24,208,
  41'BCED
140 DATA 15,9,48,41,240,9,8,141'BWUD
150 DATA 24,208,173,17,208,9,16,
  141'BBMF
160 DATA 17,208,96,162,4,160,0,
  185'BAOG
170 DATA 0,204,153,0,216,185,0,
  124'BARH
180 DATA 153,0,140,200,208,241,238,
  105'BELJ
190 DATA 122,238,108,122,238,111,122,
  238'BGUK
200 DATA 114,122,202,208,224,169,204,
  141'BGPC
210 DATA 105,122,169,216,141,108,122,
  169'BGBD
220 DATA 124,141,111,122,169,140,141,
  114'BGIE
230 DATA 122,96,32,253,174,32,212,
  225'BDHE
240 DATA 169,97,133,185,169,0,76,
  213'BCGF
250 DATA 255,32,253,174,32,158,173,
  32'BDPG
260 DATA 247,183,164,20,140,1,123,
  192'BDDH
270 DATA 2,208,3,32,14,123,172,1'BXYH
280 DATA 123,192,1,208,15,173,32,
  208'BCEJ
290 DATA 141,232,143,173,33,208,141,
  233'BFSL
300 DATA 143,32,47,123,32,253,174,
  32'BCFC
310 DATA 212,225,172,1,123,185,2,
  123'BCVD
320 DATA 133,249,185,5,123,133,250,
  185'BEIF
330 DATA 8,123,170,185,11,123,168,
  165'BDMF
340 DATA 1,41,254,133,1,169,249,
  32'BAIG
350 DATA 216,255,165,1,9,1,133,1'BXJG
360 DATA 96,0,0,0,0,160,124,204'BWTH
370 DATA 64,234,232,191,127,207,162,
  4'BDKJ
380 DATA 160,0,185,0,216,153,0,
  204'BARK
390 DATA 200,208,247,238,20,123,238,
  23'BEXM
400 DATA 123,202,208,236,169,216,141,
  20'BFUE
410 DATA 123,169,204,141,23,123,96,
  173'BEEF
```

```
420 DATA 14,220,41,254,141,14,220,
  165'BDSF
430 DATA 1,41,254,133,1,162,4,160'BYUG
440 DATA 0,185,0,140,153,0,124,
  200'BAJH
450 DATA 208,247,238,67,123,238,70,
  123'BEOJ
460 DATA 202,208,236,169,140,141,67,
  123'BFCK
470 DATA 169,124,141,70,123,173,14,
  220'BEVL
480 DATA 9,1,141,14,220,165,1,9'BWGK
490 DATA 1,133,1,96,234,234,234,
  234'BBFM
500 IF I<>45957 THEN PRINT"YOU HAVE A
  DATA ERROR. PLEASE CHECK DATA."
  :END'GHNO
510 PRINT"THE MACHINE LANGUAGE IS
  INSTALLED FOR SUPER EXPANDER."
  :END'CBCP
```

END

Program 4. Example Program

```
10 REM BA=32000 for Simons' Basic
20 REM BA=31232 for Super Expander
30 BA=XXXXX
40 SYS BA,"filename1",8 : REM load the bitmap
50 SYS BA,"filename1.hr",8 : REM load hires color
60 SYS BA,"filename1.mc",8 : REM load multicolor
70 SYS BA+6,1 : REM goto multicolor mode
80 REM look at picture
90 REM do other things if you want
100 REM save picture
110 SYS BA+3,0,"filename2",8 : REM save bitmap
120 SYS BA+3,1,"filename2.hr",8 : REM save hires color
130 SYS BA+3,2,"filename2.mc",8 : REM save multicolor
140 REM return to text mode
150 NRM : REM for Simons only
160 GRAPHIC 2: GRAPHIC 0 : REM for Super only
```

END

Program 5. BASIC Save

```
10 FOR Z=50176 TO 50764:READ Y:I=I+Y
  :POKE Z,Y:NEXT IWOH
20 DATA 76,86,196,76,101,196,76,
  108'BCOD
30 DATA 197,76,9,198,169,224,133,
  252'BDIF
40 DATA 169,0,133,251,162,32,160,
  0'BBWF
50 DATA 145,251,200,208,251,230,252,
  202'BGKH
60 DATA 208,244,169,204,133,252,169,
  0'BEHI
70 DATA 133,251,162,3,160,0,145,
  251'BCUI
80 DATA 200,208,251,230,252,202,208,
  244'BGMK
90 DATA 145,251,200,192,232,208,249,
```

64 USERS ONLY

```
169'BGJL
100 DATA 200,133,252,169,0,133,251,
162'BERB
110 DATA 4,160,0,145,251,200,208,
251'BCRB
120 DATA 230,252,202,208,244,96,32,
253'BEBD
130 DATA 174,32,212,225,169,97,133,
185'BERE
140 DATA 169,0,76,213,255,32,253,
174'BCRE
150 DATA 32,158,173,32,247,183,165,
20'BDPF
160 DATA 240,59,141,89,197,32,253,
174'BDDG
170 DATA 32,212,225,173,89,197,201,
1'BCLH
180 DATA 208,11,169,254,133,253,169,
203'BFIJ
190 DATA 133,254,76,152,196,32,232,
197'BERK
200 DATA 169,0,133,253,169,200,133,
254'BECC
210 DATA 173,32,208,141,254,203,173,
33'BEYD
220 DATA 208,141,255,203,162,232,160,
207'BGTE
230 DATA 169,253,76,216,255,32,253,
174'BEUF
240 DATA 32,158,173,32,130,183,166,
34'BDMF
250 DATA 164,35,141,167,2,134,251,
132'BDEG
260 DATA 252,160,0,177,251,153,90,
197'BDPH
270 DATA 200,204,167,2,208,245,169,
44'BDKI
280 DATA 153,90,197,169,80,200,153,
90'BDUJ
290 DATA 197,32,253,174,32,158,173,
32'BDUK
300 DATA 247,183,166,20,169,2,160,
1'BBLC
310 DATA 32,186,255,173,167,2,24,
105'BCOD
320 DATA 2,162,90,160,197,32,189,
255'BCWE
330 DATA 32,192,255,176,77,162,2,
32'BBSF
340 DATA 201,255,169,0,133,251,32,
210'BDUG
350 DATA 255,169,224,133,252,32,210,
255'BFDI
360 DATA 173,14,220,41,254,141,14,
220'BDRI
370 DATA 165,1,41,253,133,1,160,0'BYSJ
380 DATA 177,251,153,74,198,200,208,
248'BFSL
390 DATA 230,252,165,1,9,2,133,1'BXDK
400 DATA 173,14,220,9,1,141,14,
220'BARD
410 DATA 160,0,185,74,198,32,210,
255'BCNE
420 DATA 165,252,201,0,208,13,192,
63'BCCF
430 DATA 208,9,32,204,255,169,2,
32'BAMG
440 DATA 195,255,96,200,208,228,24,
144'BEOI
450 DATA 183,0,0,0,0,0,0,0'BRMG
460 DATA 0,0,0,0,0,0,0,0'BPEH
470 DATA 0,0,0,0,32,253,174,32'BVSJ
480 DATA 158,173,32,247,183,173,17,
208'BERM
490 DATA 41,239,141,17,208,165,20,
240'BDEM
500 DATA 11,173,22,208,9,16,141,
22'BAAE
510 DATA 208,32,199,197,173,2,221,
9'BBXF
520 DATA 3,141,2,221,173,0,221,41'BYMG
530 DATA 252,141,0,221,173,17,208,
9'BBDH
540 DATA 32,141,17,208,173,24,208,
41'BCEI
550 DATA 15,9,48,41,240,9,8,141'BWUI
560 DATA 24,208,173,17,208,9,16,
141'BBMK
570 DATA 17,208,173,254,203,141,32,
208'BEZM
580 DATA 173,255,203,141,33,208,96,
162'BEHN
590 DATA 4,160,0,185,0,200,153,0'BXSM
600 DATA 216,200,208,247,238,205,197,
238'BGNG
610 DATA 208,197,202,208,236,169,200,
141'BGFH
620 DATA 205,197,169,216,141,208,197,
96'BFDI
630 DATA 162,4,160,0,185,0,216,
153'BAYI
640 DATA 0,200,200,208,247,238,238,
197'BEDK
650 DATA 238,241,197,202,208,236,169,
216'BGQL
660 DATA 141,238,197,169,200,141,241,
197'BGNM
670 DATA 96,173,17,208,41,239,141,
17'BCUM
680 DATA 208,173,22,208,41,239,141,
22'BDFN
690 DATA 208,173,2,221,9,3,141,2'BXFN
700 DATA 221,173,0,221,41,252,9,3'BYWG
710 DATA 141,0,221,173,17,208,41,
223'BCUH
720 DATA 141,17,208,173,24,208,41,
15'BCFI
730 DATA 9,16,41,240,9,4,141,24'BWLI
740 DATA 208,173,17,208,9,16,141,
17'BBOK
750 DATA 208,96,0,234,234'BQHJ
760 IF I<>81119 THEN PRINT"YOU HAVE A
DATA ERROR. PLEASE CHECK DATA."
:END'GHDW
770 PRINT"THE MACHINE LANGUAGE IS
INSTALLED.":END'CBQS
```

END

Commodore 128 Graphics: Sprites

For those of you who are unfamiliar with graphics, a sprite is a programmable moveable object. Sprites can be in any one of 16 colors or multi-color. Because you can move them around the screen, sprites open the door to computer animation.

The Commodore 128 has exceptional graphics capabilities available in its "128 configuration." In this configuration, you have access to every Commodore BASIC command ever invented, including a brand new set of sprite commands. Never again will you have to whip out a sheet of graph paper to design a sprite, because you can easily create sprites right on the screen, using these new commands:

SPRSAY—Saves your picture data from a SSHAPE string into a sprite.

SPRITE—Determines the attributes of a sprite, including the sprite number, color, and whether the sprite is turned on or off. It also establishes whether the sprite passes in front of or behind background objects, whether the sprite is horizontally or vertically expanded, and whether the sprite is displayed in standard or multi-color high-resolution mode.

MOVSPR—Moves sprites from one screen location to another. You can move sprites by specifying absolute screen coordinates or positions relative to the sprite's previous screen coordinates.

COLLISION—Allows you to set interrupts according to a sprite collision with another sprite or with background objects on the screen.

SSHAPE—This statement, first seen on the Plus/4 and Commodore 16, allows the definition of an area on the screen and saves the data in a string variable. Later transfer this data string into a sprite with **SPRSAY**.

Sprite Creation

The first step in programming sprites is designing the way they look. You can create sprites in three ways:

1. Use the old-fashioned (ho hum)

Learn how to create and manipulate sprites using the newest built-in Commodore 128 graphics statements.

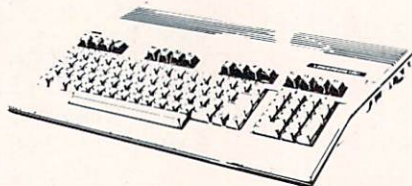

method. Using a piece of graph paper, manually code the data into DATA statements, read the data, and poke it into memory.

2. Use a Sprite Editor, like **SPRDEF** mode in the C128.

3. Use the new sprite technology in the 128 that features the **SSHAPE**, **SPRSAY** and **SPRITE** statements.

Using the **SSHAPE**, **SPRSAY** and **SPRITE** statements is the most effective way to create sprites. Here's the procedure:

Select screen colors and enter graphic mode. This is performed in standard high-resolution mode, using a black background.

```
5 COLOR 0,1 : REM COLOR
BACKGROUND
BLACK
```

```
10 GRAPHIC 1,1:REM SET STND
HI RES MODE
```

Now draw a picture (24 by 21 pixels) on the screen using **DRAW**, **CIRCLE**, **BOX** and **PAINT**. The following statements draw a picture of a racing car in the upper left corner of the screen.

```
15 BOX 1,2,2,45,45:REM DRAW
BOX AROUND CAR
```

```
20 DRAW 1,17,10 TO 28,10 TO
26,30 TO 19,30 TO 17,10:REM
CAR BODY
```

```
22 DRAW 1,11,10 TO 15,10 TO
15,18 TO 11,18 TO 11,10:REM
UP LEFT WHEEL
```

```
24 DRAW 1,30,10 TO 34,10 TO
34,18 TO 30,18 TO 30,10:REM
UP RIGHT WHEEL
```

```
26 DRAW 1,11,20 TO 15,20 TO
15,28 TO 11,28 TO 11,20:REM
LOW LEFT WHEEL
```

```
28 DRAW 1,30,20 TO 34,20 TO
```

```
34,28 TO 30,28 TO 30,20:REM
LOW RIGHT WHEEL
30 DRAW 1,26,28 TO 19,28 :REM
FRONT GRILL
32 BOX 1,20,14,26,18,90,1:REM
WINDSHIELD
35 BOX 1,150,35,195,40,90,
1:REM STREET LINE
37 BOX 1,150,135,195,140,90,
1:REM STREET LINE
40 BOX 1,150,215,195,220,90,
1:REM STREET LINE
42 DRAW 1,50,180 TO
300,180:DRAW 1,50,180 TO
50,190:REM FINISH LINE
43 DRAW 1,300,180 TO
300,190:DRAW 1,50,190 TO
300,190:REM FINISH LINE
44 CHAR 1,18,23,"FINISH":REM
PRINTS FINISH
```

Run the program. The Commodore 128 draws a white racing car enclosed in a box in the upper left corner of the screen. It also draws a raceway with a finish line on the bottom of the screen. At this point, the racing car is still only a stationary picture. The car is not yet a sprite, since you have not transferred the picture data into a sprite data area. Have patience, however. You have just completed the first major step in sprite programming.

Now save the picture into a data string with the **SSHAPE** statement:

```
45 SSHAPE A$,11,10,34,31:REM
SAVE THE PICTURE IN A STRING
```

The **SSHAPE** statement transforms the picture of the racing car into a data string. The data string, **A\$**, stores a string of zeros and ones in the computer's memory, which makes up the image of the picture you see on the screen. As in all computer graphics, the computer has a way it can represent visual graphics with bits in its memory. Each individual dot on the screen, called a pixel, has a bit in the computer's memory that controls it. If the bit in memory is equal to a one, then the pixel on the screen is turned on and becomes the color of the selected foreground color. If the controlling bit in memory is equal to a zero (off), then the pixel is turned off and becomes the background color.

Your picture is now stored in a string. Now transfer the picture data from the data string (**A\$**) into a sprite so you can animate the picture. The statement that does this is **SPRSAY**.

COMMODORE 128 USERS ONLY

```
50 SPRSAV A$,1:REM STORE DATA  
STRING IN SPRITE 1  
55 SPRSAV A$,2:REM STORE DATA  
STRING IN SPRITE 2
```

Your picture data is now transferred into sprite one and sprite two. Both sprites have the same data, so they look exactly alike. You still can't see the sprites because you have to turn them on first.

The SPRITE statement turns on a specific sprite (numbered one through eight), colors it, specifies its screen priority, expands the sprite's size if necessary, and determines which graphics mode is selected. The screen priority refers to whether the sprite passes in front of or behind the objects on the screen. Sprites can be expanded to twice their normal size in either the horizontal or vertical directions. The selected graphics mode determines whether the sprite is a standard high-resolution sprite or a multi-color sprite.

```
60 SPRITE 1,1,7,0,0,0,0:REM  
TURN ON SPR 1
```

```
65 SPRITE 2,1,3,0,0,0,0:REM  
TURN ON SPR 2
```

Here's what each of the numbers in the SPRITE statements mean:

SPRITE #,O,C,P,X,Y,M

#—Sprite number (one through eight)

O—Turn On (O = 1) or Off (O = 0)

C—Color (one through 16)

P—Priority. If P = 0, the sprite is in front of objects on the screen. If P = 1, the sprite is in back of objects on the screen.

X—If X = 1, expand the sprite in the horizontal (X) direction. If X = 0, the sprite is normal size.

Y—If Y = 1, expand the sprite in the vertical (Y) direction. If Y = 0, the sprite is normal size.

M—If M = 1, the sprite is displayed in multi-color high-resolution mode. If M = 0, the sprite is displayed in standard high-resolution mode.

Now your sprite is on the screen. All you have to do is move it. The MOVSPR statement controls the motion of a sprite and allows you to animate it. The MOVSPR statement can be used in two ways. First, the MOVSPR statement can place a sprite at an absolute location on the screen using vertical and horizontal coordinates. Add the following statements to your program:

```
70 MOVSPR 1,240,0:REM POSI  
TION SPRITE 1 AT X = 240, Y = 0
```

```
80 MOVSPR 2,120,0:REM POSI  
TION SPRITE 2 AT X = 120, Y = 0
```

Line 70 positions sprite one in (pixel) column 240, row zero. Line 80 places sprite two in (pixel) column 120, row zero. Both these positions originate in off-the-screen sprite coordinates.

You can also use the MOVSPR statement to move sprites relative to their original positions. For example, place sprites one and two at the coordinates as in lines 70 and 80. Now you want to move them from their original locations to another location on the screen. Use the following statement to move sprites along a specific route on the screen:

```
85 MOVSPR 1,180 # 6:REM MOVE  
SPRITE 1 FROM THE TOP TO THE  
BOTTOM
```

```
87 MOVSPR 2,180 # 7:REM MOVE  
SPRITE 2 FROM THE TOP TO THE  
BOTTOM
```

The first number in the above statement is the sprite number. The second number is the number of degrees to move, relative to the original position of the sprite. The pound sign (#) signifies that the sprite is moved relative to a starting position, instead of an absolute location as in lines 70 and 80. The final number specifies the speed in which the sprite moves along its route on the screen.

Now run the entire program with all the program steps included. You have just constructed your first sprite program. You have created a raceway

with two racing cars. Try adding more cars and objects. Experiment by drawing other sprites and include them in the raceway. You are now well on the way in sprite programming. Use your imagination and think of other scenes and objects you can animate. Soon enough you will be creating all kinds of animated computer "movies."

Tying Your Sprite Program Together

You now have a working sprite program example. The complete program listing follows this article. Note that, in that listing, line 5 colors the screen black. Line 10 sets standard high-resolution graphic mode. Line 15 draws a box in the top left corner of the screen. Next, lines 20 through 32 draw the racing car. Lines 35 through 44 draw the racing lanes and a finish line. Line 45 transfers the picture data from the racing car into a string variable. Lines 50 and 55 transfer the contents of the string variable into sprites one and two. Lines 60 and 65 turn on sprites one and two. Lines 70 and 80 position the sprites at the top of the screen. Finally lines 85 and 87 animate the sprites as though the two cars are racing each other across the finish line.

You have seen how to create and manipulate sprites using the newest built-in Commodore 128 graphics statements. In the future we will discuss sprite definition mode, adjoining and overlaying sprites on the Commodore 128. C

```
5 COLOR 0,1  
10 GRAPHIC 1,1  
15 BOX 1,2,2,45,45  
20 DRAW 1,17,10 TO 28,10 TO 26,30 TO 19,30 TO 17,10 :REM CAR BODY  
22 DRAW 1,11,10 TO 15,10 TO 15,18 TO 11,18 TO 11,10: REM UP LEFT WHEEL  
24 DRAW 1,30,10 TO 34,10 TO 34,18 TO 30,18 TO 30,10:REM RGHT WHEEL  
26 DRAW 1,11,20 TO 15,20 TO 15,28 TO 11,28 TO 11,20:REM LOW LFT WHEEL  
28 DRAW 1,30,20 TO 34,20 TO 34,28 TO 30,28 TO 30,20:REM LO RGHT WHEEL  
30 DRAW 1,26,28 TO 19,28  
32 BOX 1,20,14,26,18,90,1  
35 BOX 1,150,35,195,40,90,1:REM STREET  
37 BOX 1,150,135,195,140,90,1:REM STREET  
40 BOX 1,150,215,195,220,90,1:REM STRT  
42 DRAW 1,50,180 TO 300,180:DRAW 1,50,180 TO 50,190:DRAW 1,300,180 TO 300,190  
43 DRAW 1,50,190 TO 300,190  
44 CHAR 1,18,23,"FINISH"  
45 SSHAPE AS,11,10,34,31:REM SAVE SPR IN AS  
50 SPRSAV AS,1:REM SPR1 DATA  
55 SPRSAV AS,2:REM SPR2 DATA  
60 SPRITE 1,1,7,0,0,0,0:REM SPR1 ATTRIB  
65 SPRITE 2,1,3,0,0,0,0:REM SPR2 ATTRIB  
70 MOVSPR 1,240,0  
80 MOVSPR 2,120,0  
85 MOVSPR 1,180 # 6  
90 MOVSPR 2,180 # 7  
95 FOR I=1TO5000:NEXT  
99 GRAPHIC 0,1
```

USER GROUPS

Commodore user groups nationwide and around the world provide invaluable assistance to Commodore computerists. If you are looking for people who share your computing interests, or if you need help getting started with your computer, contact the group near you.

This list is compiled from groups who responded to a survey conducted by Pete Baczor, Commodore's user group coordinator. If you would like your group to appear here, or if you need information about Commodore's user group support, contact Pete at Commodore Business Machines, 1200 Wilson Drive, West Chester, PA 19380.

ALABAMA

Birmingham
Birmingham Commodore
Computer Club
Harry Jones
4845 Avenue V Lot 7-B—35208
205-923-9260

Enterprise
Wiregrass Micro-Computer
Society
William H. Brown
109 Key Bend Rd.—36330
205-347-7564

Mobile
Commodore Club of Mobile
Tom Wyatt
3868-H Rue Maison—36608
205-343-1178

Pinson
Commodore Club—South
William J. Freeman
P.O. Box 324—35126
205-854-0650

Scottsboro
Scottsboro C-64 Users' Group
Richard Radon
Rt. 5, Box 255—35768
205-574-1830

ALASKA

Calgary
Calgary Commodore
Users Group
Lloyd Norman
810 Canfield Way SW—T2W 1K1
403-281-2772

Anchorage
Alaska 84 Commodore
Computer Club
Doug Gannon
P.O. Box 6043—99502
907-248-3451

Ketchikan
First City Users Group
Jim Llanos
P.O. Box 6002—99901
907-225-5695

Sitka
Sitka Commodore Users Group
Dennis Lanham
P.O. Box 2204—99835
907-747-3491

ARIZONA

Chandler
Arizona VIC & 64 Users
Thomas Monson
904 W. Marlboro Cir.—85224
602-963-6149

Globe
Gila Hackers
Paul R. Machula
Rt. 1, Box 34—85501
602-425-7260

Phoenix
Phoenix Arizona Commodore
Club
Leslie A. Roberts
P.O. Box 34905—85067
602-265-4296

Sierra Vista
Thunder Mountain Commodore
Users Gp
Jeff Tyler
P.O. Box 1796—85636
602-458-0320

Tucson
Catalina Commodore
Computer Club
Mike LaPaglia
3371 S. Mctron Dr.—85730
602-721-7824

ARKANSAS

Conway
Commodore/PET Users Club

Geneva Bowlin
Davis Street—72032
501-329-3415

Russellville
Russellville Commodore
Users Group
Bob Brazeal
401 S. Arlington Dr.—72801
501-967-1868

CALIFORNIA

Altaloma
Cactus Communicator
P.O. Box 1277—91701
714-865-4816

Arcadia
Pasadena Commodore
Computer Club
Ernie McDonald
P.O. Box 1163—91006
818-904-0607

Auburn
Auburn Commodore
Computer Club
Pat Strub
11210 Mira Loma Dr.—95603
916-823-7095

Baldwin Park
Cal Poly Commodore Users
Group
David Dietzel
14617 1/2 Ramona Blvd.—91706
818-960-9906

Bellflower
Club 64
Robert Johnson
14944 Bayou Ave.—90706

Chatsworth
San Fernando Valley
Commodore Users Group
Tom Lynch
21208 Nashville—91311
818-709-4736

Clovis
Fresno 64 Users
Greg Edwards
091 W. 9th #203—93612
209-297-7093

Concord
Diablo Valley Commodore
Users Group
Dean Steichen
P.O. Box 27155—94520

Costa Mesa
C Tech Users of Orange County
R. Stevenson
P.O. Box 1497—92626

Cupertino
PUG of Silicon Valley
Marvin Vander Kool
22355 Rancho Ventura—95014
408-446-1936

Danville
Danville Users Group
Kent E. Davis
185 Front St., Suite 106—94526
415-820-1223

Hollywood
Hollywood Commodore
Users Group
Martin Blackwell
733 N. Ridgewood Blvd.—90038
213-463-8973

Livermore
PALS
Jo Johnson
886 South K—94550
415-449-1084

Los Osos
San Luis Obispo Commodore
Comp. Cl.
Gary Bissell
1766 9th Street—93402
805-528-3371

Nevada City

C64 Users Group
Gerry Friederici
11614 Red Dog Road—95959
916-265-6532

Ojai
64/20 Club
Greg Burns
215 N. Fulton St.—93023
805-646-0617

Oxnard
CIVIC 64
Nathan Okum
120 W. Magnolia Ave.—93030
805-985-8150

Pasadena
P.C.A.C.C.
Brian Klotz
1135 Coronet Ave.—91107
213-351-8198

San Carlos
Peninsula Commodore
Users Group

Timothy Avery
543 Old County Rd.—94070
415-595-2497

San Francisco
PET on the AIR
Bola Lowe
525 Crestlaine Dr.—94132
415-681-7520

San Ysidro
South Bay Commodore 64
Users Group
Jose M. Gallego
P.O. Box 3193—92073
619-420-5887

Santa Maria
Central Coast Commodore
User Group
Gilbert F. Vela
4237 Plumeria Ct.—93455
805-937-4174

Santa Monica
Commodore 64 West
Don Campbell
P.O. Box 406—90406-0406
213-828-9308

Santa Rosa
Santa Rosa Commodore 64
Users Group
Garry Palmer
333 E. Robles Ave.—95407-7925
707-584-7009

Stockton
Stockton Commodore
Users Group
Rita McCann
2929 Calariva Dr.—95204
209-948-5890

COLORADO

Aspen
Rocky Mountain Commodore
Club
Ray Brooks
P.O. Box 377—81612
303-923-5037

Denver
Colorado Commodore Computer
Club
Royce Mitchell
9400 Elm Ct. #6078—80221
303-427-1309

Grand Junction
Western Slope Commodore
Users Group
Ralph D'Andrea
P.O. Box 4142—81502
303-242-8990

CONNECTICUT

Colchester
Computer Users Group
Liz Rafolowski
Halls Hill Road—06415
203-267-9501

Danbury
Fairfield County Commodore
User Gp.
Kenneth H. Hottes
P.O. Box 212—06810
203-797-0076

East Hartford
Hartford County Commodore
User Gp.
R. Curtiss
P.O. Box 8553—06018

Enfield
Northern CT Commodore Club
Mike Levesque
3 Marble St.—06082
203-745-8209

Hampton
Commodore East Computer
Users Group
Ernest Julian
165 B.S. Bigelow Rd.—06247
203-455-0108

Mystic
C64 Users Group of New London
A. Estes
57 Fishtown Ln.—06355

Stamford
Stamford Commodore
Users Group
Stan Czernel
P.O. Box 1337—06902
203-325-4381

Stratford
Commodore User Group of
Stratford
Dan Kern-Ekins
P.O. Box 1213—06497
203-336-1981

West Haven
U of New Haven Microcomputer
Club
M. McConeghy
U of New Haven, 300 Orange
Ave.—06516

DELAWARE

Felton
Diamond State Users Group
Michael Butler
P.O. Box 892—19943
302-284-4495

Newark
Newark Commodore Users
Group
Bob Taylor
210 Durso Dr.—19711
302-737-4686

FLORIDA

Avon Park
CHIPS Users Group
Gerald Klimczak
P.O. Box 3063—33825
813-452-2304

Bradenton
Manasota Commodore
Users Group
Bob Bronson
916 E. 35th Ave. Dr.—33508
813-747-1785

Brandon
Brandon Users Group
Paul A. Daugherty
108 Anglewood Dr.—33511
813-685-5138

Clearwater
Clearwater Commodore Club
Gary B. Gould
1532 Lemon Street—33516
813-442-0770

Cocoa
El-shift-oh
Mike Schnoke
P.O. Box 548—32922-0548

Eaton Park
VIC/64 Heartland User Group—

Lakeland
Randall Lipham
P.O. Box 912—33840
813-666-1692

Gainsville
Gainsville Commodore
Users Group
M. Drew Hurley
P.O. Box 14716—32604
904-462-3128

Jacksonville
UNF Commodore Computer
Club
Jay S. Huebner
University of North Florida—
32216
904-646-2729

Lutz
VIC/64 Heartland Users—Tampa
Tom Keough
14806 Morning Dr.—33549
813-977-2016

MacDill, AFB
South Tampa Commodore 64
Users Group
Ronald S. Clement
736F Second Dr.—33621
813-840-0682

Miami
Miami 2064
Jim Luftman
12911 SW 49th St.—33175
305-226-1185

North Miami Beach
Commodore Educators User
Group—North
Robert Figueroa
16330 NE 2nd Ave.—33162
305-944-5548

Ocala
Tri-County Commodore
Users Group
Don Vanderverter
P.O. Box 1151—32671
904-629-1220

Orlando
Central Florida Commodore
Users Group
Thurman Lawson
P.O. Box 7326—32854
305-886-0390

Palm Harbor
Suncoast 64s
Curtis J. Miller
2419 US 19 North—33563
813-785-1036

Panama City
Bay Commodore Users Group
Doug Schipall
P.O. Box 3187—32401
904-785-2314

Pensacola
Commodore Advantage
Deanna Owens
P.O. Box 18490—32523
904-456-6554

Pensacola
Commodore Users Group of
Pensacola
Debbie Johnston
P.O. Box 3533—32506
904-455-5804

Plantation
Suburban 64 Users Group
Ken Partridge
1360 SW 82nd Ter. Apt #625—
33324
305-474-6923

Sanibel
Sanibel Commodore VIC
Phil Belanger
1119 Periwinkle Box 73—33957
813-472-3471

Shalmer
Ft. Walton Beach Commodore

USER GROUPS

<p>User Group Jim Moore P.O. Box 3—32549 904-651-3737</p> <p>Tamarac Broward Commodore Users Group Lewis Horn P.O. Box 25794—33320 813-726-4390</p> <p>Tavares Triangle Educational Users Group John Zeigler P.O. Box 326—32778 904-343-4499</p> <p>Zephyrhill East Pasco Commodore Users Group P.J. Bryden 1836 Sandy Road—34248 813-567-6089</p> <p>GEORGIA</p> <p>Albany Albany CBM Amateur Computerist David L. Via P.O. Box 5461—31706 912-436-5596</p> <p>Atlanta VIC-tims Earl Dobney P.O. Box 467052—32346</p> <p>Brunswick Golden Isles Commodore Users Richard L. Young 135 Sherwood Forest Cir.— 31520</p> <p>College Park Commodore Format Gregory Young 2804 Camp Creek Pkwy—30337 404-767-2487</p> <p>Morrow CCC 64 UG David Padett P.O. Box 842—30260 404-968-4154</p> <p>Oakwood NE Georgia Commodore Users Group Randy Shuler Route #2, Box 226—30566 404-534-1142</p> <p>Riverdale Clayton County C64 Users Group Joyce Jay 527 Wanely Way—30274 404-478-7906</p> <p>Stowe Mountain Atlanta C64 Users Group Ronald Lisoski 1767 Big Valley Lane—30083 404-981-4253</p> <p>IDAHO</p> <p>Coeur d'Alene Coeur d'Alene Computer Club Gary Edwards 506 Lunceford Ln.—83814 208-765-3803</p> <p>Grangeville Grangeville HS Computer Club Don Kissingner 910 S. 'D' Street—83530 208-983-4366</p> <p>Idaho Falls Eagle Rock Commodore Computer Club Jeanie Larson P.O. Box 3884—83403-3884 208-529-4738</p> <p>ILLINOIS</p> <p>Belvidere Heuristics Users Group Chip Downey 1303 Nettle #2—61008</p> <p>Bloomington Bloomington-Normal Commodore ug Carl Burress P.O. Box 1058—61702-1058 309-828-3783</p> <p>Canton Canton Area Commodore Users Group</p>	<p>Robert S. Smolich Spoon River College, RR #1— 61520 309-647-2710</p> <p>Champaign Champaign Urbana Commodore Users Group Steve Gast 2006 Crescent Dr.—61821 217-352-9681</p> <p>Elgin Fox Valley Commodore Users Group Herb Gross 833 Prospect—60120 312-695-1316</p> <p>Galesburg Knox Commodore Club Randy Fox 195 Olive St.—61401 309-343-5334</p> <p>Harvey South Suburban V20 Users Club Nick Forte 16409 Emerald—60426 312-331-4851</p> <p>Kankakee Kankakee Hackers Bill Brouillet R.R. #2, Box 228-H—60901 813-937-1083</p> <p>Lincolnwood C-64 Users Group, Inc. David W. Tamkin P.O. Box 46464—60646 312-583-4629</p> <p>Monmouth Western Illinois Commodore Users Group Robert Cokel 906 W. 6th Ave.—61462 309-734-5589</p> <p>Peoria Commodore Users of Peoria Jeff Martin 1600 W. Devereux—61614 309-692-0230</p> <p>Rockford Rockford Area Commodore Computer Club Kathe Heyer 2507 Pelham Rd.—61107 815-963-8773</p> <p>Scott AFB Scott Computer Users' Group Gilbert D. Helland P.O. Box 397—62225 618-746-2732</p> <p>Springfield Springfield PET Users Group Bill Eardley 3116 Concord—62704 217-753-8500</p> <p>INDIANA</p> <p>Columbus Columbus Commodore Club Frank Nicholas 11210 W. Georgetown Rd.— 47201 812-342-6805</p> <p>Indianapolis VIC Indy Club Fred Imhausen Box 11543, 4812 E. Michigan St.—46201</p> <p>N. Manchester Manchester Commodore Users Group Richard M. Bellows 6060 E. 9th St.—46902</p> <p>Terra Haute Western Indiana Commodore Users Group Dennis C. Graham 912 E. Brown Ave.—47803 812-234-5099</p> <p>W. Lafayette Commodore Owners of Lafayette Ross Indelicato 20 Patrick Lane—47906 317-743-3410</p> <p>IOWA</p> <p>Des Moines Commodore Computer Users of Iowa</p>	<p>Curtis L. Shiffer P.O. Box 3140—50316 515-282-1388</p> <p>Hartford Capital Complex Commodore Computer Club Doren Hulet P.O. Box 58—50118 515-989-0568</p> <p>Waterloo Waterloo Area Commodore Club Rick Volker 945 Lowell—50702 319-232-1062</p> <p>KANSAS</p> <p>Hutchinson Salt City Commodore Club Wendell D. Hinkson P.O. Box 2644—67504 316-662-2392</p> <p>Viola Commodore Users Group of Wichita, Inc. Walt Lounsbury Rt. #1, Box 115—67149 316-545-7460</p> <p>KENTUCKY</p> <p>Bardstown Commodore Bardstown Users Group Patrick Kirtley P.O. Box 165—40004 502-348-6360</p> <p>Bowling Green Bowling Green Commodore Users Group Doug Skinner P.O. Box 20214—42102 502-841-0483</p> <p>Glasgow Glasgow Commodore Users Group Steve England P.O. Box 154—42141 502-678-3609</p> <p>Henderson Commodore Connection James Kemp 1010 S. Elm—42420 502-827-8153</p> <p>LOUISIANA</p> <p>Metairie Sixty-Four 'Um Users' Group Elizabeth S. Hoffman 4317 Stockton St.—70001 504-831-7950</p> <p>New Orleans Control Data Institute Kent H. Courtney II 6600 Plaza Dr.—70127 504-245-1604</p> <p>Shreveport Ark-La-Tex Commodore 64 Club Bill Walker 5515 Fairfax Ave.—71108 318-636-3611</p> <p>Sulphur Southwest LA Users' Group Fred White 99 Ann—70663 318-625-5148</p> <p>Swartz Ouachita Commodore Club Beckie Walker P.O. Box 175—71281 318-343-8044</p> <p>MAINE</p> <p>Brunswick Y.U.G. (Brunswick) Peter O'Brien 20 Columbia Ave.—04011 207-725-4580</p> <p>Orano Computer Society of Penobscot Art Pete 101 Crosby Lab, UMO—04469 207-827-4542</p> <p>Portland Southern Maine 20/64 Ed Moore 10 Walker Street—04092 207-871-0111</p> <p>Scarborough Y.U.G. (Scarborough)</p>	<p>George Caswell 16 Westwood—04074 207-883-3362</p> <p>Westbrook Your Commodore Users Group Mike Prociase P.O. Box 611—04092 207-854-4579</p> <p>MARYLAND</p> <p>Aberdeen COMPUCATS Betty Scheuler 680 W. BelAir Ave.—21001 301-272-0472</p> <p>Baltimore Baltimore Area Commodore Uses Group Michael M. Broumberg 4605 Vogt Ave.—21206 301-325-2156</p> <p>Westinghouse BWI Commodore User Group Lee D. Barron P.O. Box 1693—21203</p> <p>Woodlawn Commodore Club Mike Long 1712 Aberdeen Rd.—21234 301-788-4641</p> <p>Fallston Harford County Commodore Users Group Kim Lloyd P.O. Box 209—21047 301-879-3583</p> <p>Frederick Frederick Functioneers Stephen M. Jacobson 108 Key Pkwy—21701 301-663-1471</p> <p>Hagerstown Hagerstown Users Group Joseph F. Rutkowski 23 Coventry Ln.—21740 301-797-9728</p> <p>Leonardtown PAX/COM/64 David J. Hamblin 240 Jefferson St.—20650 301-475-8440</p> <p>Potomac Western Montgomery C64 Users Group Jorge Montalvan 11209 Tack House Ct.—20854 301-983-8199</p> <p>Rockville RockvilleVIC/64 Users Group Tom Pounds P.O. Box 8805—20856 301-231-7823</p> <p>Silver Springs Montgomery County Commodore Soc. Meryle B. Pounds P.O. Box 6444—20906 301-946-1564</p> <p>Suitland Edison Commodore Users Group William H. Harr 4314 Oxford Dr.—20746</p> <p>MASSACHUSETTS</p> <p>Bedford Raytheon Commodore Users Group John Rudy Raytheon Co.—GRA6—017730 617-861-0402</p> <p>Foxboro Foxboro Area Commodore User Group Samuel Knight 154 Green St.—02035 617-543-4291</p> <p>Rutland The Polyhedral Wizard Rob Hodgson Jr. 422 Countryside Est.—01543</p> <p>Westfield Pioneer Valley VIC/64 Club Marvin S. Yale 34 Bates St.—01085</p>	<p>413-562-1027</p> <p>Woburn EM 20/64 Users Group John Chaplain 36 Buckman St.—01801 617-935-3490</p> <p>MICHIGAN</p> <p>Ann Arbor Commodore User Group— U of Mich. John J. Gannon School of Pub. Health— U of Mich.—48109</p> <p>Bay City Bay City Users Group Jim Griffin 1013 N. Johnson St.—48706 517-893-1106</p> <p>Clare Mid-Michigan Commodore Club Virgil Graham —48617 517-386-3429</p> <p>East Detroit Michigan Commodore 64 User Group, Inc. Chuck Ciesliga P.O. Box 539—48021 313-773-6302</p> <p>Madison Heights Slipped Disk, Inc. J. Moskow 31044 John R—48071 313-583-9803</p> <p>Midland Commodore Computer Club Jack Walley 4106 West Man Rd.—48460 517-836-5138</p> <p>Richmond COMP Brian Pringle 7514 Putty Gutt Rd.—48062 313-329-2625</p> <p>Southfield Commodore Computer Enthusiasts Steven Lepsetz 20050 Winchester—48076 313-354-7224</p> <p>Waterliet DAB Computer Club Dennis Burlington P.O. Box 542—49098 616-463-5457</p> <p>MINNESOTA</p> <p>Little Falls Heartland Area Computer Co-op Sam Walz 2401 Riverwood Dr.—56345 612-632-5511</p> <p>Redwood Falls Interface Ron Schilling 243 E. 2nd St.—56283 507-637-8381</p> <p>MISSISSIPPI</p> <p>Biloxi Gulf Coast Commodore Club Mark W. Harvey 4550 W. Beach Blvd.—39531 601-74-4084</p> <p>Hattiesburg Commodore Computer Club Len J. Mathias Dept. of Poli. Sci.—U of Miss— 39406-0076</p> <p>MISSOURI</p> <p>Cape Girardeau Heartland Users Group Mason Emerson 129 S. Lorimer #7—64701 314-334-9462</p> <p>Golden MOARK Commodore Users Group Marshall B. Turner P.O. Box 504—65658 417-271-3293</p>
----------------------------------------------------------------------------------------------------------------------------------------------------------------------------------------------------------------------------------------------------------------------------------------------------------------------------------------------------------------------------------------------------------------------------------------------------------------------------------------------------------------------------------------------------------------------------------------------------------------------------------------------------------------------------------------------------------------------------------------------------------------------------------------------------------------------------------------------------------------------------------------------------------------------------------------------------------------------------------------------------------------------------------------------------------------------------------------------------------------------------------------------------------------------------------------------------------------------------------------------------------------------------------------------------------------------------------------------------------------------------------------------------------------------------------------------------------------------------------------------------------------------------------------------------------------------------------------------------------------------------------------------------------------------------------------------------------------------------------------------------------------------------------------------------------------------------------------------------------------------------------------------------------------------------------------------------------------------------------------------------	--------------------------------------------------------------------------------------------------------------------------------------------------------------------------------------------------------------------------------------------------------------------------------------------------------------------------------------------------------------------------------------------------------------------------------------------------------------------------------------------------------------------------------------------------------------------------------------------------------------------------------------------------------------------------------------------------------------------------------------------------------------------------------------------------------------------------------------------------------------------------------------------------------------------------------------------------------------------------------------------------------------------------------------------------------------------------------------------------------------------------------------------------------------------------------------------------------------------------------------------------------------------------------------------------------------------------------------------------------------------------------------------------------------------------------------------------------------------------------------------------------------------------------------------------------------------------------------------------------------------------------------------------------------------------------------------------------------------------------------------------------------------------------------------------------------------------------------------------------------------------------------------------------------------------------------------------------------------------------------------------------------------------------------------------------	-------------------------------------------------------------------------------------------------------------------------------------------------------------------------------------------------------------------------------------------------------------------------------------------------------------------------------------------------------------------------------------------------------------------------------------------------------------------------------------------------------------------------------------------------------------------------------------------------------------------------------------------------------------------------------------------------------------------------------------------------------------------------------------------------------------------------------------------------------------------------------------------------------------------------------------------------------------------------------------------------------------------------------------------------------------------------------------------------------------------------------------------------------------------------------------------------------------------------------------------------------------------------------------------------------------------------------------------------------------------------------------------------------------------------------------------------------------------------------------------------------------------------------------------------------------------------------------------------------------------------------------------------------------------------------------------------------------------------------------------------------------------------------------------------------------------------------------------------------------------------------------------------------------------------------------------------------------------------------------------------------------------------	-------------------------------------------------------------------------------------------------------------------------------------------------------------------------------------------------------------------------------------------------------------------------------------------------------------------------------------------------------------------------------------------------------------------------------------------------------------------------------------------------------------------------------------------------------------------------------------------------------------------------------------------------------------------------------------------------------------------------------------------------------------------------------------------------------------------------------------------------------------------------------------------------------------------------------------------------------------------------------------------------------------------------------------------------------------------------------------------------------------------------------------------------------------------------------------------------------------------------------------------------------------------------------------------------------------------------------------------------------------------------------------------------------------------------------------------------------------------------------------------------------------------------------------------------------------------------------------------------------------------------------------------------------------------------------------------------------------------------------------------------------------------------------------------------------------------------------------------------------------------------------------------------------------------------------------------------------------------------------------------------	----------------------------------------------------------------------------------------------------------------------------------------------------------------------------------------------------------------------------------------------------------------------------------------------------------------------------------------------------------------------------------------------------------------------------------------------------------------------------------------------------------------------------------------------------------------------------------------------------------------------------------------------------------------------------------------------------------------------------------------------------------------------------------------------------------------------------------------------------------------------------------------------------------------------------------------------------------------------------------------------------------------------------------------------------------------------------------------------------------------------------------------------------------------------------------------------------------------------------------------------------------------------------------------------------------------------------------------------------------------------------------------------------------------------------------------------------------------------------------------------------------------------------------------------------------------------------------------------------------------------------------------------------------------------------------------------------------------------------------------------------------------------------------------------------------------------------------------------------------------------------------------------------------

USER GROUPS

Joplin
Joplin Commodore Computer Users
R.D. Connely
422 S. Florida Ave.—64801
417-624-5259

Kansas City
Commodore Users Group of Kansas City
Salvador Cerda
P.O. Box 36492—64111
816-252-7628

Liberty
Northland Amateur Radio Association
Alan Boyer
811 Lindenwood Lane—64068
816-784-4312

Maryville
Commodore PAC
Patricia Lucido
Horace Mann Learning Center—64468
816-562-4498

Warrensburg
Commodore User Group of Warrensburg
Buck Sommerkamp
P.O. Box 893—64093
816-747-2406

MONTANA

Missoula
Western Montana Commodore User Group
Carl White
800 Kensington Ave.—59601
406-728-5124

NEBRASKA

Alliance
Alliance Commodore Computer Club
M. Seller
1629 Boise—69301
308-762-6228

Gering
Platte Valley Commodore Users Group
Jim Parks
1720 'O' St.—69341
308-436-3211

Lincoln
Computer Power Unlimited
Robert Howard
416 N. 27—68503
402-475-8081

Omaha
Greater Omaha C64 Users Group
Ken Jirele
2932 Leawood Dr.—68123
402-592-3254

NEVADA

Las Vegas
Las Vegas Area PET Users Group
5130 E. Charleston Blvd.—89122
702-453-3544

Las Vegas
SOG Commodore Users Group
Lee Schram
4011 W. Charleston Blvd.—89102
702-646-5656

NEW HAMPSHIRE

Rochester
C-64 U.S.E.R.S.
P.O. Box 4022—03867

Winchester
Monadnock Commodore 64 Users Group
Paul Rule III
RFD #1 Route 10—03470
603-352-6722

NEW JERSEY

Rochester
Commodore Computer Club
N. Threuisen
1111 Stewart Ave.—11714
516-475-5269

Bronx
Commodore Microchips
Anthony Sanchez
340 E. Mosholu Pkwy.—10458

Brooklyn
Brooklyn Commodore Users Group
Malcolm Jay Gottesman
1735 E. 13th St. Apt. #7N—11229
718-375-5278

Belle Mead
ACGNJ PET/VIC/CBM Users Group
Joseph M. Pylka
30 Riverview Ter.—08502
201-359-3862

Cherry Hill
South Jersey Commodore Users Group
Fred Herman
P.O. Box 4205—08034
609-227-7905

Freehold
F.T.C.U.
John Rinaldi
150 Starling Ave.—07728
201-431-4297

Morris Plains
Morris Area Commodore Users Group
Robert J. Searing
51 Ferncliff Rd.—07950
201-267-5231

Morris Plains
N. American Commodore Teachers Users Group
Robert J. Searing
51 Ferncliff Rd.—07950
201-267-5231

Mount Holly
RCA Commodore Users Group
William Rowe
432 Hemlock Ln.—08060
609-234-7656

Ocean View
Cape-Atlantic Commodore Users Group
B. J. Chadwick
1440 Old Stage Coach Rd.—08230
609-398-6111

Ridgewood
INFO 64
Pete Nissely
16 W. Ridgewood Ave.—07432
201-445-6335

Union City
Hudson County Commodore User Group
Dave Westphalen
308 Palisade Ave.—07087
201-864-7299

Wall Township
Jersey Shore Commodore Users Group
Bob McKinley
1905 Monmouth Blvd.—07728
201-542-2113

Wayne
Club 64
G. Cipolletti
Hamburg Tpke.—07470
201-595-5463

Westwood
Commodore 64 Beginners Club
Thomas Martin
680 Leigh Ter.—076765
201-664-3304

NEW YORK
APO New York
Zweibruecken Commodore Computer Club
Henry White
200th TAMMC, Box 114—09052
06332-6347

Bethpage
Commodore Computer Club
N. Threuisen
1111 Stewart Ave.—11714
516-475-5269

Bronx
Commodore Microchips
Anthony Sanchez
340 E. Mosholu Pkwy.—10458

Brooklyn
Brooklyn Commodore Users Group
Malcolm Jay Gottesman
1735 E. 13th St. Apt. #7N—11229
718-375-5278

East Setauket

Long Island VIC Society
Lawrence V. Stefani
20 Spyglass Lane—11733
516-751-7844

Great Neck
Great Neck Commodore Users Group
Adam Korn
30 Grace Ave.—11021
516-482-5480

Great Neck
LIVE
A. Friedman
17 Picadilly Road—11023
516-482-3982

Hammondsport
Finger Lakes Area Komputer Experts
Terry Lynne Narby
86 W. Lake Rd.—14840
607-868-3674

Jaberg
Commodore Freaks
Mike West
9111 Railroad St.—13471
516-336-4858

Mt. Vernon
Folkite Terminal Club
Ted Corales
Box 2222-C—10551

New Hampton
C-64 Users Group of Orange County
Stephen Gerstl
Box 238 RD #1—10958
914-355-1478

New Platz
Computer Metropolis
Eric Dean
P.O. Box 39—171 Main St.—12561

New York
New York Commodore Users Group
Ben Tunkelang
380 Riverside Dr. 7Q—10025

New York
New York City V20/C64 Users Group
Ralph Lees
103 Waverly Place—10011

Newark
Finger Lakes Commodore Users Group
Todd Andrews
229 W. Union St.—14513
315-331-3266

Oswego
Oswego Commodore Users Group
John R. Boronkay
208 Park Hall—SUNY—13126
315-343-6069

Rochester
Commodore Users Group of Rochester
P.O. Box 26514—14626

Saratoga Springs
Adirondack C64 Users Group
Paul W. Klompas
208 Woodlawn Ave.—12866
518-584-8960

Syracuse
Commodore Computer Club of Syracuse
P.O. Box 2232—13220

Tallman
Computer Club of Rockland
Peter Bellin
P.O. Box 233—10982
914-357-8941

Tonawanda
64 Southtowns Users Group
Michael Leskow
504 Somerville—14150
716-837-5643

Tonawanda
Commodore Buffalo Users Group
David Newton
199 Dale Dr.—14150
716-695-1026

Tribes Hill
Mohawk Valley Commodore Users Group
William A. Nowak
3818 Stinson Ave., P.O. Box 343—12177
518-829-7576

NORTH CAROLINA

Charlotte
Charlotte C64 Users Group
H. S. Hanks
3717 Flowerfield Rd.—28210
704-552-1094

Havelock
Down East Commodore Users Group
Jim Worthington
302 Belltown Rd.—28532
914-447-4601

Tryon
Tryon Commodore 64 Club
Robin Michael
P.O. Box 1016—28782
704-859-6340

NORTH DAKOTA

Bismarck
Commodore Club of North Dakota
James G. Allen
16067 Reno Dr.—58501
701-222-4377

OHIO
Brook Park
C.P.U. Connection
Burke Frank
P.O. Box 42032—44142
216-236-8890

Cincinnati
Commodore Users of Blue Chip
Ted Stalets
816 Beecher St.—45206
513-961-6582

Maple Heights
SE Cleveland Commodore
Crazies Users Group
Carl Skala
18873 Harlan Dr.—44137
216-581-3099

Marion
Marion Ohio Commodore Users Group
Richard Munro
775 Wolfinger Rd.—43302
614-726-2630

Mentor
NE Ohio Commodore Users Group
Ross Black
P.O. Box 718—44062
216-942-4132

Milford
Clercom-64
Dave Skaggs
5771 Observation Ct.—45150
513-831-5684

New Philadelphia
Commodore 64 Users Group
Jeff Eklund
702 Park Ave. NW—44663
216-364-6158

Toledo
Commodore Computer Club of Toledo
Jim Cychlen
P.O. Box 8909—43623
419-475-9160

Xenia
Dayton Area Commodore Users Group
Charles Tobin
679 Murray Hill Dr.—45385
513-372-4077

OKLAHOMA

Muskogee
Muskogee Computer Soc.
Commodore Users Group
Steve Ford
202 S. 12th Street—74401
405-683-5290

Oklahoma City
Greater Oklahoma Commodore Club
Richard P. Hill
1401 N. Rockwell—73127
405-787-1644

OREGON

Albany
Albany Corvallis C64 Users Group
Al Rasmus
2138 Chicago St. SE—97321

503-967-8701
Portland
NE Portland Commodore User Group
Gary A. Thompason
8759 N. Calvert Ave.—97217
503-285-4791

Portland
PGE Commodore Users Group
Richard Turnock
121 SW Salmon St.—97005
914-447-4197

Prineville
Central Oregon C64 Users Group
Marvin McCleary
499 N. Harwood Ave.—97754
503-447-7062

Sheridan
Yamhill County Commodore Users Group
Dan Linscheid
Route 2, Box 246—97378
503-843-2625

PENNSYLVANIA

Altoona
Altoona & Martinsburg Commodore Users Group
Ralph Osmolinski Jr.
R.D. #4 Box 258—16601
814-946-0691

Altoona
B.A.S.I.C.
Dimitri N. Dantos
1433 13th Ave.—16603
814-942-9565

Apollo
Hackers Elite Club
Joe Moore
305 Route 356—15613
412-568-3592

Berwyn
GE Com64
Edward Davidson
507 Westwind Dr.—19312
215-296-3329

Blue Bell
Worldwide Commodore Users Group
Dave Walter
P.O. Box 337—19422
215-948-6542

Clarks Summit
Scranton Commodore Users Group
Mark A. Davis
P.O. Box 211—18411
717-586-9443

Clifton Heights
C.H.U.G.
Kevin J. Daly
P.O. Box 235—19018
215-622-6550

Greensburg
Westmoreland Computer Users Club
Gary Means
3021 Ben Venus Dr.—15601
412-836-2224

Morrisville
Lower Bucks Users Group
Don Moyer
252 Mansfield Rd.—19067
215-295-3591

Mount Holly Springs
Eight Squared
Andy Skelton
P.O. Box 76—17065
717-486-3274

New Kensington
A-K 64 Users Group
Alton Glubish
1762 Fairmount St.—15068
412-335-9070

Philadelphia
Boeing Emp. Personal Computer Club
Alina McNichol
P.O. Box 16858 P32-31—19142

Pittsburgh
Bettis Commodore Users Group
Bill Campbell
592 Arbor Lane—15236
Pittsburgh Commodore Group
Joel A. Casar
2015 Garrick Dr.—15235

USER GROUPS

412-371-2882
V.U.G.O.P.
Davin Plateau
1931 Rockledge—15212
412-322-4662

Salona
Central PA User Group
for Commodore
Joseph W. Coffman
Box 102—17767
717-726-4564

West Chester
Main Line Commodore
Users Group
Emil J. Volcheck Jr.
1046 General Allen Ln.—19382
215-388-1581

West Mifflin
South Pittsburgh
Commodore Group
Charles W. Groves III
2407 Pennsylvania Ave.—15122
412-466-9002

RHODE ISLAND

Harrisville
Burrillville Commodore
Users Club
David R. Migneault
28 Cherry Farm Rd.—02850
401-568-4397

Narragansett
Narragansett Commodore
Users Group
Robert R. Payne
South Ferry Rd.—02882
401-885-2458

Pawtucket
R.I.C.E.
Michael Skeldon
198 Morris Ave.—02860
401-728-8602

SOUTH CAROLINA

Cayce/W. Columbia
Commodore Computer Club
of Columbia
Buster White
P.O. Box 2775—29171
803-772-0305

Myrtle Beach
Commodore Update
Brad Bannon
230 Tarpon Bay—29577

North Charleston
Charleston Computer Society
Jack A. Furr Jr.
P.O. Box 5264—29406
803-747-0310

Rock Hill
Rock Hill Commodore
User Group
Smarzik Robbie
565 Scaleybark Cir.—29730
803-366-7918

Spartanburg
SPARCUG
James B. Pasley
385 S. Spring St.—29302
803-582-5897

TENNESSEE

Bartlett
Memphis Commodore
Users Club
Steven A. Gaines
P.O. Box 38095—38134-0095
901-358-5823

Estill Springs
Commodore Computer Club
Marty Garner
P.O. Box 96—37330
615-649-5962

Knoxville
ET 64 Users Group
Rick McCall
P.O. Box 495—37901

Metro Knoxville Commodore
Users Group
Edward Pritchard
7405 Oxmoor Rd.—37931
615-938-3773

Soddy-Daisy
C64/VIC 20/ +4 Club
Aaron Kennedy
2414 Blue Ridge Dr.—37379
615-842-9419

TEXAS

Austin
Commodore Computer Club
of Austin
Roy Holmes
P.O. Box 49138—78765

Corpus Christi
Corpus Christi Commodores
Jim O'Rear
P.O. Box 6541—78411
512-852-7665

Dallas
64 Users Group, Inc.
Stan Gordin
P.O. Box 801828
13604 Midway Rd.—75380
214-239-7665

Hurst
Mid Cities Commodore Club
Diane Dews
413 Chisolm Trail—76053
817-485-4747

Irving
Irving Commodore Users Group
Bill Marshall
P.O. Box 165034—75016
214-256-1402

Longview
Longview Users Group
Dorothy Metzler
P.O. Box 9284—75608
214-759-0699

Lubbock
Lubbock Commodore
Users Group
Robert Massengale
3817 64th Drive—79413
806-797-3958

Mexia
BiStone Users Club
R.G. Gore
P.O. Box 386—76667
817-562-6808

Victoria
Crossroads Commodore
Users Group
Jerry Guy
417 Irma Dr.—77901
512-575-0342

Waco
Computas
Burl A. Hays
Route 4 Box 214—76705
817-799-8192

UTAH

Ogden
Wasatch Commodore
Users Group
Mike Murphy
P.O. Box 4028—84402
801-394-4952

VERMONT

S. Burlington
Champlain Valley Commodore
Users Group
Steve Lippert
6 Mayfair St.—05401
802-658-4160

VIRGINIA

Alexandria
Alexandria Users Group
Jeffrey K. Hendrickson
1206 Westgrove Blvd.—22307
703-768-4571

Franconia Commodore
Users Group
Mark Sowash
5924 Dovee Dr.—22310
703-971-5021

Arlington
Arlington Victims (20/64)
Clifton Gladley
4501 Arlington Blvd.—22204
703-524-0236

Crystal City Commodore 64 Club
Greg Selezynski
1235 Jefferson Davis Hwy.
Ste 1200—22202

Dale City
Dale City Commodore
Users Group
Jack B. Doyle
P.O. Box 2004—22193-0058
703-590-1825

Fairfax
PENTAF
Ron Thomas
9912 Colony Rd.—22030

Franklin
Commodore Users of Franklin
Bruce Powell
1201 N. High St.—23851
804-562-6823

Hardy
Roanoke Computer Society
Larry Washburn
Rt. 1, Box 40—24101
703-890-2044

Hurt
Central Virginia Users Group
Dale Moore
Route 3, Box 451—24563
804-324-4054

McLean
C64 Users Group of McLean
John Mueller
7426 Eldorado St.—22102
703-356-2030

Roanoke
R.A.C.E. Commodore
Users Group
Larry Rackow
4726 Horseman Dr.—24019
703-362-8960

WASHINGTON

Arlington
Arlington Commodore
Users Group
Jane M. King
18204 67th Ave. NE—98223
206-653-3882

Centralia
CBM Users Group
Rick Beaber
803 Euclid—98531
206-736-4085

Ft. Lewis
64 PCS
Jim Litchfield
Quarters 2821-A—99433
206-964-1444

Marysville
Bunch 'A' Bytes
Joey Miller
4916 121st Place NE—98272
206-653-5675

Oak Harbor
Whidbey Island Commodore
Computer Club
Bob Hardy
P.O. Box 1471, #203—98277
206-675-3889

Puyallup
PNB Users Group
Rod Small
9105 158th St. E.—98373
206-848-0037

Richland
Tri City Commodore
Computer Club
Jack Garvin
1926 Pine St.—99352
509-943-4734

Seattle
C.O.M.P.U.T.E.R.
Art Witbeck
5303 Shilshale Ave. NW—98107
206-481-3037

NNW Commodore Users Group
Richard Ball
2565 Dexter N. #203—98109
206-284-9417

University 64 Users Group
Allen M. Grown
Pathology SM-30
Univ. of Washington—98195

Tacoma
World Wide Users Group
R. Smith
P.O. Box 98682—98498
206-535-0334

WISCONSIN

Caledonia
C.L.U.B. 84
Jack White
P.O. Box 72—53108
414-835-4645

Eau Claire
Eau Claire Area CBM 64

Users Group
John F. Slasky Jr.
Rte. 5 Box 179A—54703
715-874-5972

Green Bay
Comm Bay 64
Richard F. Luxton
P.O. Box 1152—54305
414-336-3956

Madison
Madison Area Commodore
Users Group
Napolian Smith
1850 Beld #11—53713
608-252-8760

Menomonee
Menomonee Area Commodore
Users Gp.
Mike Williams
510 12th St.—54725
715-246-6991

Milwaukee
M.A.C.E.
John Postman
6332 W. Manitoba St.—53219
414-545-8451

Racine
C.U.S.S.H.
Tim Trammel
3614 Sovereign Dr.—53406
414-554-0156

WYOMING

Cheyenne
Cheyenne Assn. of
Comp. Enthusiasts
William Holden
505 Williams St. #260—82007
307-778-7074

Lander
ZYMEC Users Group
Tim Struna
Rte 63, Box 357
11 Birchfield Ln.—82520
307-332-7655

CANADA

Belleville
Baden Computer Club
Ben Brash
P.O. Box 1219—CFPO 5056—
KOK 3R0
07229-3791

Fergus
CWDHS Users Group
Jerry Rogerson
155 Belsyde St. East—N1M 1Y7

Hamilton
TRACK 64
Wayne Chapman
491 Kenilworth Ave. N.—
H4H 4T6
416-545-4581

Kimberley
Kootenay Computer Club
Tom Lang
348 Archibald St.—V1A 1M9
604-427-2527

Montreal
C64 Users Group of Montreal
Robert Adler
Snowdon P.O. Box 792—
H3X 3X9
514-729-3046

St. Catherines
Niagara Commodore
Users Group
Ian Kerry
44 Queenston St. Unit 12—
L2R 2Y9
416-688-5529

Stoney Creek
Eastdale Commodore
Users Group
R.W. Harasen
275 Lincoln Rd.—L8E 1Z4
416-578-2236

Toronto
Toronto PET Users Group
Chris Bebbett
1912A Avenue Rd. Suite 1—
M5M 4A1
416-782-9252

Victoriaville
C.P. 884
Michael Laganiere
—G6P 8Y1
819-357-2553

MEXICO

Mexico City D.F.
Club Herra*Tec C64
Alain Bojmal
Vicente Suarez 25—06140
903-294-1243

User Group Support Program

Commodore is creating a program to support Commodore User Groups.

The two major components—an electronic bulletin board on CompuServe and a newsletter are now available.

The electronic bulletin board is a dedicated section of the Commodore Information Network of CompuServe accessible only by "Approved" User Groups. It will be used for direct communication as well as Commodore announcements.

The newsletter, INPUT/OUTPUT, will include announcements, user group programs, calendar of events, letters, questions, product specifications, programs, and surveys. It will be a newsletter FOR user groups BY user groups supported by Commodore without advertisements.

For future issues of the newsletter Commodore is accepting announcements of user group activities, articles of interest, letters to the editor, and general questions.

Please forward all correspondence with the name of your user group to:

Commodore Business Machines
1200 Wilson Drive
West Chester, PA 19380
Attn: Jim Gracely

XDOS

Continued from page 51
the system pointers.

Now you should be able to do LOAD "XDOS",8,1 (make sure to include the ",1"). Next do SYS828:NEW and you are all set. The machine language program is less than 200 bytes long, so it fits into one disk block and loads very quickly. A hex listing (Listing 2) is also included for those who may wish to enter XDOS from a machine language monitor. The asterisks in the hex listing should be replaced with "C" if you are using a VIC 20 or else "A" on the Commodore 64.

This simple routine, ECHO, shown in Figure 8, should help you determine if you have XDOS working correctly. It simply echos all of its arguments (up to ten).

Customizing XDOS

The locations in the XDOS code shown in Figure 9 are useful for customizing XDOS to suit particular needs.

Using XDOS

XDOS is an "empty" operating system in which you fill in the commands to meet your needs and tastes. Many different varieties of commands are possible. "Switches" can be passed to commands by having arguments of the form -XYZ (or whatever form you wish) where XYZ request special options. This can be more convenient in regular use than having a program ask every time what options the user wishes. Various types of command syntax can be implemented with XDOS.

For debugging purposes, you may wish to set ARG\$'s elements at the beginning of the command under development. Also, you might have your program "prompt" for arguments left off the command line, so your programs can run with or without XDOS.

The definition of XDOS lies in what it does, and not how it does it. Because of this, it should be quite simple to implement on other Commodore computers, and not much harder to set up on any computer. Since all the commands are written in BASIC, they are as portable as any system can be. How XDOS actually loads, runs and creates ARG\$ could vary from computer to computer without affecting the commands themselves. **C**

MASTER COMPOSER

Continued from page 28

a few simple commands. Since the music files are played from machine language called during the 64's hardware interrupts (every 1/60 of a second), a BASIC program continues to run while the song is playing. As a result, music or sound effects recorded as *Master Composer* music files are very easy to build into your own programs.

The noise level in the *Master Composer* playback mode is quite high. This is due to the electronic noise generated by the 64's operating system when it has to maintain and update a high-resolution graphics screen while music is playing. There are substantially lower noise levels when there is no screen activity. (This noise problem is not specific to *Master Composer*, but will be encountered with any music program that uses high-resolution graphics while playing music.)

As with all step-entry music programs, entering music from the computer keyboard one note at a time can be tedious. However, *Master Composer's* cursor-driven entry is easy to use and the conventional musical interpretation of notes, rests, key signatures, sharps, flats, and naturals makes the job as painless as possible.

Master Composer adds remarkably few limitations of its own. There are only 12 allowable key signatures, but this range covers the most commonly used keys. It's not possible to change the time signature of a composition from the value established at the beginning. This makes rhythmically free or very complex music a little more difficult to enter into the measures because you have to think of the measures as groups of notes that may not relate directly to the rhythmic emphasis of the music. This problem can be minimized by judicious allocation of blocks in the program mode. Triplets, trills, and notes shorter than a sixteenth note cannot be directly programmed, but they may easily be realized by manipulation of the block tempo parameter.

It's not possible to copy one voice into another. This would be a convenient feature for monophonic melodies, where two or three SID voices can be programmed in unison for a "fatter" and more interesting sound. When you play the current measure from the input mode, the voice set-

tings of the first block, including the tempo setting, are used regardless of which block is actually assigned to play that measure.

Master Composer will not print its music files in conventional notation. However, in the program mode, you can direct the current block screen or sequence page to a printer. This is straightforward because the program screen uses no special graphics.

A separate program on the *Master Composer* disk allows you to print music files in *Master Composer's* own perfectly readable pseudo-staff notation. But if you really need music printed in conventional musical notation, then you may find *Master Composer* unsuitable.

The strong points of *Master Composer* far outweigh whatever minor restrictions it imposes. Of these, the block concept for describing sequences and sounds and the ease with which music files can be played from within BASIC are especially noteworthy.

Master Composer's operation is thoroughly described in its manual. (An errata sheet is included, something that many manuals need but never get.) The manual also describes the location and format of information within the music files so you can write your own music editor if you like. (For example, you could easily write a program that would copy one voice into another and thereby eliminate one of the minor restrictions noted above.) Finally, the manual shows you how to link several music files together from BASIC.

Having all program functions on a single disk eliminates the time-consuming program disk swapping required with some SID music packages. Because each *Master Composer* music file contains all the information required to play and edit a composition, manipulation of data disks is minimized, too.

In summary, I find *Master Composer* to be extremely powerful and easy to use. It is well documented and, as far as I can tell, totally bug free. This is a significant accomplishment that is a credit to Paul Kleimeyer, *Master Composer's* author, and to Access Software. In my opinion, you won't find a better SID music utility program anywhere. **C**

HOW TO ENTER PROGRAMS

The programs which appear in this magazine have been run, tested and checked for bugs and errors. After a program is tested, it is printed on a letter quality printer with some formatting changes. This listing is then photographed directly and printed in the magazine. Using this method ensures the most error-free program listings possible.

Whenever you see a word inside brackets, such as [DOWN], the word represents a keystroke or series of keystrokes on the keyboard. The word [DOWN] would be entered by pressing the cursor-down key. If multiple keystrokes are required, the number will directly follow the word. For example, [DOWN4] would mean to press the cursor-down key four times. If there are multiple words within one set of brackets, enter the keystrokes directly after one another. For example, [DOWN, RIGHT 2] would mean to press the cursor-down key once and then the cursor-right key twice.

In addition to these graphic symbols, the keyboard graphics are all represented by a word and a letter. The word is either SHFT or CMD and represents the SHIFT key or the Commodore key. The letter is one of the letters on the keyboard. The combination [SHFT E] would be entered by holding down the SHIFT key and pressing the E. A number following the letter tells you how many times to type the letter. For example, [SHFT A4,CMD B3] would mean to hold the SHIFT key and press the A four times, then hold down the Commodore key and press the B three times.

The chart on this page tells you the keys to press for any word or words inside brackets. Refer to this chart whenever you aren't sure what keys to press. The little graphic next to each keystroke shows you what you will see on the screen.

SYNTAX ERROR

This is by far the most common error encountered while entering a program. Usually (sorry folks) this means that you have typed something incorrectly on the line the syntax error refers to. If you get the message "?Syntax Error Break In Line 270", type LIST 270 and press RE-

TURN. This will list line 270 to the screen. Look for any non-obvious mistakes like a zero in place of an O or vice-versa. Check for semicolons and colons reversed and extra or missing parenthesis. All of these things will cause a syntax error.

There is only one time a syntax error will tell you the 'wrong' line to look at. If the line the syntax error refers to has a function call (i.e., FN A(3)), the syntax error may be in the line that defines the function, rather than the line named in the error message. Look for a line near the beginning of the program (usually) that has DEF FN A(X) in it with an equation following it. Look for a typo in the equation part of this definition.

ILLEGAL QUANTITY ERROR

This is another common error message. This can also be caused by a typing error, but it is a little harder to find. Once again, list the line number that the error message refers to. There is probably a poke statement on this line. If there is, then the error is referring to what is trying to be poked. A number must be in the range of zero to 255 to be poke-able. For example, the statement POKE 1024,260 would produce an illegal quantity error because 260 is greater than 255.

Most often, the value being poked is a variable (A,X...). This error is telling you that this variable is out of range. If the variable is being read

from data statements, then the problem is somewhere in the data statements. Check the data statements for missing commas or other typos.

If the variable is not coming from data statements, then the problem will be a little harder to find. Check each line that contains the variable for typing mistakes.



































OUT OF DATA ERROR

This error message is always related to the data statements in a program. If this error occurs, it means that the program has run out of data items before it was supposed to. It is usually caused by a problem or typo in the data statements. Check first to see if you have left out a whole line of data. Next, check for missing commas between numbers. Reading data from a page of a magazine can be a strain on the brain, so use a ruler or a piece of paper or anything else to help you keep track of where you are as you enter the data.

OTHER PROBLEMS

It is important to remember that the 64 and the PET/CBM computers will only accept a line up to 80 characters long. The VIC 20 will accept a line up to 88 characters long. Sometimes you will find a line in a program that runs over this number of characters. This is not a mistake in the listing. Sometimes programmers get so carried away crunching programs that they use abbreviated commands to get more than 80 (or 88)

CHART OF SPECIAL CHARACTER COMMANDS

 "[HOME]" = UNSHIFTED CLR/ HOME	 "[PURPLE]" = CONTROL 5	 "[F1]" = F1
 "[CLEAR]" = SHIFTED CLR/HOME	 "[GREEN]" = CONTROL 6	 "[F2]" = F2
 "[DOWN]" = CURSOR DOWN	 "[BLUE]" = CONTROL 7	 "[F3]" = F3
 "[UP]" = CURSOR UP	 "[YELLOW]" = CONTROL 8	 "[F4]" = F4
 "[RIGHT]" = CURSOR RIGHT	 "[ORANGE]" = COMMODORE 1	 "[F5]" = F5
 "[LEFT]" = CURSOR LEFT	 "[BROWN]" = COMMODORE 2	 "[F6]" = F6
 "[RVS]" = CONTROL 9	 "[L. RED]" = COMMODORE 3	 "[F7]" = F7
 "[RVOff]" = CONTROL 0	 "[GRAY1]" = COMMODORE 4	 "[F8]" = F8
 "[BLACK]" = CONTROL 1	 "[GRAY2]" = COMMODORE 5	 "[POUND]" = ENGLISH POUND
 "[WHITE]" = CONTROL 2	 "[L. GREEN]" = COMMODORE 6	 "[SHFT]" = PI SYMBOL
 "[RED]" = CONTROL 3	 "[L. BLUE]" = COMMODORE 7	 "[]" = UP ARROW
 "[CYAN]" = CONTROL 4	 "[GRAY3]" = COMMODORE 8	

GRAPHIC SYMBOLS WILL BE REPRESENTED AS EITHER THE LETTERS SHFT (SHIFT) AND A KEY ("[SHFT Q,SHFT J,SHFT D,SHFT S]") OR THE LETTERS CMDR (COMMODORE) AND A KEY ("[CMDR Q,CMDR G,COMDR Y,CMDR H]"). IF A SYMBOL IS REPEATED, THE NUMBER OF REPITITIONS WILL BE DIRECTLY AFTER THE KEY AND BEFORE THE COMMA ("[SPACE3,SHFT S4,CMDR M2]").

characters on one line. You can enter these lines by abbreviating the commands when you enter the line. The abbreviations for BASIC commands are on pages 133-134 of the VIC 20 user guide and 130-131 of the Commodore 64 user's guide.

If you type a line that is longer than 80 (or 88) characters, the computer will act as if everything is ok, until you press RETURN. Then, a syntax error will be displayed.

THE PROGRAM WON'T RUN!!

This is the hardest of problems to resolve; no error message is displayed, but the program just doesn't run. This can be caused by many small mistakes typing a program in. First check that the program was written for the computer you are using. Check to see if you have left out any lines of the program. Check each line of the program for typos or missing parts. Finally, press the RUN/STOP key while the program is 'running'. Write down the line the program broke at and try to follow the program backwards from this point, looking for problems.

IF ALL ELSE FAILS

You've come to the end of your rope. You can't get the program to run and you can't find any errors in your typing. What do you do? As always, we suggest that you try a local user group for help. In a group of even just a dozen members, someone is bound to have typed in the same program.

If you do get a working copy, be sure to compare it to your own version so that you can learn from your errors and increase your understanding of programming.

If you live in the country, don't have a local user group, or you simply can't get any help, write to us. If you do write to us, include the following information about the program you are having problems with:

The name of the program

The issue of the magazine it was in

The computer you are using

Any error messages and the line numbers

Anything displayed on the screen

A printout of your listing (if possible)

Send your questions to:

Commodore Microcomputers
1200 Wilson Drive
West Chester, PA 19380
ATTN: Program Problem

How to Use the Magazine Entry Program

The Magazine Entry Program on page 123 is a machine language program that will assist you in entering the programs in this magazine correctly. It is for use with the Commodore 64 only and was written by Mark Robin using the IEA Editor/Assembler. Once the program is in place, it works its magic without you having to do anything else. The program will not let you enter a line if there is a typing mistake on it, and better yet, it identifies the kind of error for you.

Getting Started

Type in the Magazine Entry Program carefully and save it as you go along (just in case). Once the whole program is typed in, save it again on tape or disk. Now RUN the program. The word POKING will appear on the top of the screen with a number. The number will increment from 49152 up to 50052, and just lets you know that the program is running. If everything is ok, the program will finish running and end. Then type NEW. If there is a problem with the data statements, the program will tell you where to look to find the problem.

Once the program has run, it is in memory ready to go. To activate the program, type SYS49152 and press RETURN. When the READY prompt is displayed, type TEST and press RETURN. You are now ready to enter the programs from the magazine.

Typing the Programs

All the program listings in this magazine that are for the 64 have an apostrophe followed by four letters at the end of the line (i.e., 'ACDF). The apostrophe and letters *should* be entered along with the rest of the line. This is a checksum that the Magazine Entry Program uses.

Enter the line and the letters at the end and then press RETURN, just as you normally would.

If the line is entered correctly, a bell is sounded and the line is entered into the computer's memory (without the characters at the end).

If a mistake was made while entering the line, a noise is sounded and an error message is displayed. Read the error message, then press any key to erase the message and correct the line.

IMPORTANT

If the Magazine Entry Program sees a mistake on a line, it *does not* enter that line into memory. This makes it impossible to enter a line incorrectly.

Error Messages and What They Mean

There are six error messages that the Magazine Entry Program uses. Here they are, along with what they mean and how to fix them.

NO CHECKSUM: This means that you forgot to enter the apostrophe and the four letters at the end of the line. Move the cursor to the end of the line you just typed and enter the checksum.

QUOTE: This means that you forgot (or added) a quote mark somewhere in the line. Check the line in the magazine and correct the quote.

PARENTHESIS: This means that you forgot (or added) a parenthesis somewhere in the line. Check the line in the magazine again and correct the parenthesis.

KEYWORD: This means that you have either forgotten a command or spelled one of the BASIC keywords (GOTO, PRINT..) incorrectly. Check the line in the magazine again and check your spelling.

OF CHARACTERS: This means that you have either entered extra characters or missed some characters. Check the line in the magazine again. This error message will also occur if you misspell a BASIC command, but create another keyword in doing so. For example, if you misspell PRINT as PRONT, the 64 sees the letter P and R, the BASIC keyword ON and then the letter T. Because it sees the keyword ON, it thinks you've got too many characters, instead of a simple misspelling. Check spelling of BASIC commands if you can't find anything else wrong.

UNIDENTIFIED: This means that you have either made a simple spelling error, you typed the wrong line number, or you typed the checksum incorrectly. Spelling errors could be the wrong number of spaces inside quotes, a variable spelled wrong, or a word misspelled. Check the line in the magazine again and correct the mistake. **C**

C The Magazine Entry program is available on disk, along with the other programs in this magazine, for a small fee. Contact Loadstar at 1-800-831-2694 to order.

Magazine Entry Program

```
1 PRINT "[CLEAR]POKING-";
5 P=49152:REM $C000
10 READ A$:IF A$="END"THEN 80
20 L=ASC(MID$(A$,2,1))
30 H=ASC(MID$(A$,1,1))
40 L=L-48:IF L>9 THEN L=L-7
50 H=H-48:IF H>9 THEN H=H-7
60 PRINT"[HOME,RIGHT12]"P;
70 B=H*16+L:POKE P,B:T=T+B:P=P+1
:GOTO 10
80 IF T<>103233 THEN PRINT"MISTAKE IN
DATA --> CHECK DATA STATEMENTS":END
90 PRINT"DONE":END
1000 DATA 4C,23,C0,00,00,00,00,00
1001 DATA 00,00,00,00,00,00,00,00
1002 DATA 00,58,C1,5E,C1,66,C1,76
1003 DATA C1,83,C1,8F,C1,EA,EA,EA
1004 DATA 4C,83,C0,A2,05,BD,1D,C0
1005 DATA 95,73,CA,10,F8,60,A0,02
1006 DATA B9,00,02,D9,3C,C1,D0,0B
1007 DATA 88,10,F5,A9,01,8D,10,C0
1008 DATA 4C,1F,C1,60,A0,03,B9,00
1009 DATA 02,D9,38,C1,D0,E0,88,10
1010 DATA F5,A9,00,8D,10,C0,4C,1F
1011 DATA C1,60,A0,03,B9,00,02,D9
1012 DATA 34,C1,D0,E0,88,10,F5,A0
1013 DATA 05,B9,A2,E3,99,73,00,88
1014 DATA 10,F7,A9,00,8D,18,D4,4C
1015 DATA 1F,C1,E6,7A,D0,02,E6,7B
1016 DATA 4C,79,00,A5,9D,F0,F3,A5
1017 DATA 7A,C9,FF,D0,ED,A5,7B,C9
1018 DATA 01,D0,E7,20,5A,C0,AD,00
1019 DATA 02,20,A3,C0,90,DC,A0,00
1020 DATA 4C,EA,C1,C9,30,30,06,C9
1021 DATA 3A,10,02,38,60,18,60,C8
1022 DATA B1,7A,C9,20,D0,03,C8,D0
1023 DATA F7,B1,7A,60,18,C8,B1,7A
1024 DATA F0,35,C9,22,F0,F5,6D,05
1025 DATA C0,8D,05,C0,AD,06,C0,69
1026 DATA 00,8D,06,C0,4C,BD,C0,18
1027 DATA 6D,07,C0,8D,07,C0,90,03
1028 DATA EE,08,C0,EE,0B,C0,60,18
1029 DATA 6D,0A,C0,8D,0A,C0,90,03
1030 DATA EE,09,C0,EE,0C,C0,60,0A
1031 DATA A8,B9,11,C0,85,FB,B9,12
1032 DATA C0,85,FC,A0,00,A9,12,20
1033 DATA D2,FF,B1,FB,F0,06,20,D2
1034 DATA FF,C8,D0,F6,20,54,C3,20
1035 DATA 7E,C3,20,E4,FF,F0,FB,A0
1036 DATA 1B,B9,3F,C1,20,D2,FF,88
1037 DATA 10,F7,68,68,A9,00,8D,00
1038 DATA 02,4C,74,A4,4B,49,4C,4C
1039 DATA 54,45,53,54,41,44,44,91
1040 DATA 91,0D,20,20,20,20,20,20
1041 DATA 20,20,20,20,20,20,20,20
1042 DATA 20,20,20,20,20,20,91,0D
1043 DATA 51,55,4F,54,45,00,4B,45
1044 DATA 59,57,4F,52,44,00,23,20
1045 DATA 4F,46,20,43,48,41,52,41
1046 DATA 43,54,45,52,53,00,55,4E
1047 DATA 49,44,45,4E,54,49,46,49
1048 DATA 45,44,00,4E,4F,20,43,48
1049 DATA 45,43,4B,53,55,4D,00,50
1050 DATA 41,52,45,4E,54,48,45,53
1051 DATA 49,53,00,C8,B1,7A,D0,FB
1052 DATA 84,FD,C0,09,10,03,4C,C7
1053 DATA C1,88,88,88,88,88,B1,7A
1054 DATA C9,27,D0,13,A9,00,91,7A
1055 DATA C0,A2,00,B1,7A,9D,3C,03
1056 DATA C8,E8,E0,04,D0,F5,60,4C
1057 DATA F2,C2,A0,00,B9,00,02,99
1058 DATA 40,03,F0,F2,C8,D0,F5,A0
1059 DATA 00,B9,40,03,F0,E8,99,00
1060 DATA 02,C8,D0,F5,20,D7,C1,4C
1061 DATA 56,C2,A0,0B,A9,00,99,03
1062 DATA C0,8D,3C,03,88,10,F7,A9
1063 DATA 80,85,02,20,1B,C3,A0,00
1064 DATA 20,9B,C1,20,CA,C1,20,31
1065 DATA C2,E6,7A,E6,7B,20,7C,A5
1066 DATA A0,00,20,AF,C0,F0,CD,24
1067 DATA 02,F0,06,20,D7,C0,4C,12
1068 DATA C2,C9,22,D0,06,20,BC,C0
1069 DATA 4C,12,C2,20,E7,C0,4C,12
1070 DATA C2,A0,00,B9,00,02,20,A3
1071 DATA C0,C8,90,0A,18,6D,09,C0
1072 DATA 8D,09,C0,4C,33,C2,88,A2
1073 DATA 00,B9,00,02,9D,00,02,F0
1074 DATA 04,E8,C8,D0,F4,60,18,AD
1075 DATA 0B,C0,69,41,8D,0B,C0,38
1076 DATA AD,0C,C0,E9,19,90,06,8D
1077 DATA 0C,C0,4C,60,C2,AD,0C,C0
1078 DATA 69,41,8D,0C,C0,AD,05,C0
1079 DATA 6D,07,C0,48,AD,06,C0,6D
1080 DATA 08,C0,8D,0E,C0,68,6D,0A
1081 DATA C0,8D,0D,C0,AD,0E,C0,6D
1082 DATA 09,C0,8D,0E,C0,38,E9,19
1083 DATA 90,06,8D,0E,C0,4C,96,C2
1084 DATA AD,0E,C0,69,41,8D,0E,C0
1085 DATA AD,0D,C0,E9,19,90,06,8D
1086 DATA 0D,C0,4C,AB,C2,AD,0D,C0
1087 DATA 69,41,8D,0D,C0,A0,01,AD
1088 DATA 0B,C0,CD,3C,03,D0,20,C8
1089 DATA AD,0C,C0,CD,3D,03,D0,17
1090 DATA C8,AD,0D,C0,CD,3E,03,D0
1091 DATA 0E,AD,0E,C0,CD,3F,03,D0
1092 DATA 06,20,64,C3,4C,7A,C0,AD
1093 DATA 10,C0,D0,11,98,48,68,4C
1094 DATA F7,C0,AD,10,C0,F0,01,60
1095 DATA A9,04,4C,F7,C0,A4,FD,A9
1096 DATA 27,91,7A,A2,00,C8,BD,0B
1097 DATA C0,91,7A,C8,E8,E0,04,D0
1098 DATA F5,A9,00,91,7A,20,64,C3
1099 DATA 4C,7A,C0,A0,00,B9,00,02
1100 DATA F0,11,C9,28,D0,03,EE,03
1101 DATA C0,C9,29,D0,03,EE,04,C0
1102 DATA C8,D0,EA,AD,03,C0,CD,04
1103 DATA C0,D0,01,60,A9,05,4C,F7
1104 DATA C0,A9,20,8D,00,D4,8D,01
1105 DATA D4,A9,09,8D,05,D4,A9,0F
1106 DATA 8D,18,D4,60,20,41,C3,A9
1107 DATA 81,20,77,C3,A9,80,20,77
1108 DATA C3,4C,71,C3,20,41,C3,A9
1109 DATA 11,20,77,C3,A9,10,20,77
1110 DATA C3,A9,00,8D,04,D4,60,8D
1111 DATA 04,D4,A2,70,A0,03,88,D0
1112 DATA FD,CA,D0,FA,60,END
```

WRITE FILE

Continued from page 36

Though *The Write File's* word processor possesses advanced features, the program's true versatility and power comes to light after the file manager has been integrated into the processor for customized report generation.

This manager handles the most common chores with straightforward simplicity: mailing lists, inventory records (LP's, tapes, disks) business files, stamp and coin collection data. The list of applications is almost endless. Use it for whatever comes to mind.

Once the data disk has been created, you have to create a file format on the blank "canvas." The limits are a maximum of 17 fields per record with 38 characters per field. Up to 999 records can be stored on a single floppy.

Once the data areas have been specified, the information can be keyed in. The data can be sorted, changed or copied to other fields as well as merged with the word processor. File formats, unfortunately, can't be altered once they've been finalized. So make certain the information required won't change, or if in doubt, leave a blank field or two within each file.

Groups of records can be sorted alphabetically, by zip code or by any other means up to a maximum of three fields per record. High and low search parameters can establish sub-sorts. These and any others can be viewed and then reset to their original order.

All commands consist of two letters and (where needed) numerical entries. For example: "ud" stands for update a record and "rv11" means review record 11. These are issued from the command mode (hit F1 to enter) and activated by RETURN.

The merge routine for accessing file data from the word processor is also driven by alphanumeric commands. Location start and stop, end of file merge, read first record, and move to specified record are all legitimate inputs. Others include field name and field data merge.

The Write File gives 64 users some of the sophistication that was previously the sole province of computers costing five times as much. All in all, *The Write File* is a good program for use in the home, small business and school. C

TUK

Continued from page 87

woods are full of hidden shapes (easier) or letters (harder) which can be uncovered with the number keys.

After each game, the child can choose to play again or continue with Tuk's journey. When Tuk gets to town, his vehicle stops, he climbs out and wanders up and down the street past storefronts. Three of the stores offer options for going inside and playing a game. The Toy Store contains a which-is-not-like-the-others pattern recognition game, where each correct answer reveals a letter of a secret toy-store word. In the Market, there's a pattern-matching/decoding game, where finding correct shapes spells food names and balances an on-screen scale. The Clothes Store is full of funny clothes. The game here is to dress Tuk up, just for fun. When the child is tired of playing these games (that may take a while), she can send Tuk home the way he came and send him on a different trip to town another day.

The plot of *Tuk Goes to Town* isn't likely to capture the imagination of literary critics, but it's just right for preschoolers and older kids to enjoy the interactive nature of the story. The visuals may not be high art, but they're as charming and imaginative as some of the best children's book illustrations. The games won't guarantee your child a ticket on the fast track at school, but they will provide an entertaining way to practice important developmental skills.

This program is supposedly for four to eight year-old children, but parents of four and five year-olds shouldn't expect it to serve as an electronic babysitter. For one thing, the player needs reading skills—or help from somebody older with those skills. Also, youngsters may find it frustrating to use the keyboard to make all those menu choices and game responses. It's hard for the uninitiated to find the right key (for example, P to play a game) and easy to accidentally hit a wrong key (F1, which terminates any game and brings back the opening menu). Some other Tink!Tonk! programs allow for joystick control, which most children find easier. And children of all ages are apt to get tired of waiting between screens while the 64 pulls the next scene off of the disk. C

RNDM THOUGHTS

Continued from page 64

adding commas, periods, and so forth would probably increase the measured accuracy of a program.

How can you improve on these programs? First, you may want to add better display routines. As designed above, the machine's predictions get typed over as you put in the chosen text. You might want the computer's guesses to appear on a line above or below the line the human types on. That is not hard to do, using cursor-control characters, but I avoided it for simplicity in my listings. You also may want to automate the scorekeeping, and display a running total of how well the machine is doing somewhere on the screen. I simply interrupted program execution when I finished putting in the text, and asked BASIC to print out the values of N, R, and R/N. You can do something nicer, I'm sure, if you try.

You can certainly increase a program's score right from the start by initializing its arrays properly. Perhaps best would be to fill the arrays of *Textrapolation 1* and *Textrapolation 2/3* with the number "32", the character for "space." Spaces are likely to be the most common symbol in your typed text, and starting out with lots of spaces will help your program's early performance. In the long run, however, the initialization shouldn't matter. The program will learn from whatever you type in. The scanning program *Textrapolation 123* automatically chooses to echo back the latest input character, if it is given something it hasn't seen before (within its 239-character memory). It might do better by defaulting to a "space" guess as well.

Finally, and more difficult, you can revise the programs to improve their efficiency. *Textrapolation 123*, in particular, runs too slowly to be comfortable to the user. If you clean up the logic, or perhaps use a more sophisticated string-matching algorithm, I'm sure it can be made to perform far better.

Best of all, why not think of a completely different approach to the problem of "textrapolation"? Maybe you can get something much better than I've found. If you think your program is good enough, why don't you type in the text of this article, and let it generate an alternative ending! C

While the airports claim that this is harmless, the wise traveler doesn't take chances. I learned this the hard way, since I've already had film fogged by the x-ray scanners.

It's a good idea to request visual inspection of your disks, cassettes and film rather than trust their fate blindly to these "harmless" devices. If you feel that digging your disks out of your packed bags is too much trouble, then at least get yourself a lead-foil safety pouch from your local photo dealer. These light-weight pouches will shield your magnetic media from the potentially harmful x-rays, and they cost only a few dollars each. Since they can be reused indefinitely, they're cheap insurance.

They won't protect your disks or cassettes from magnetic interference, however, so I'm a great fan of visual inspection. I usually keep my disks in a lead-foil pouch inside my carry-on flight bag, while the rest of my equipment is packed safely away. This makes it easy to get them out and present them for visual inspection while I walk through the metal detector. Perhaps I'm being overly careful, but I'm happy to say that I've never lost any data on my disks (or fogged any more film, for that matter) by taking these precautions.

Avoid Disasters

Regardless of where you plan to spend your vacation—at home or abroad—there are some general rules you should observe. Never use your computer near a swimming pool, shower, lawn sprinkler or anywhere near water. In addition to damaging your Commodore or peripherals, you may be the victim of a fatal electric shock.

The same glorious sunshine that will turn you into a human lobster will likewise ruin your equipment. Floppy disks, cassettes, monitors, disk drives, and of course, computers, are all highly susceptible to heat damage. Not only will the plastic melt, internal damage to the electronic components will result. The tan of your 64 is fine just the way it is—don't cook your computer!

Sand and surf, while being wonderful for humans, are positively awful for computer equipment and should be avoided like the plague. Sand can infiltrate your keyboard, disk drive or

While the airports claim that x-ray equipment is harmless, the wise traveler doesn't take chances.

printer, and it can do lots of damage. Just one grain of the gritty stuff will wreak havoc on the magnetic surface of a disk or cassette.

Salt sea air spells double trouble for metal and electronic components. The corrosive salt particles are insidiously carried in the sea air, which is laden with moisture, the second enemy of your equipment. Both salt and moisture are gremlins that cause malfunctions.

Computer Vacations

Computer camps, workshops, cruises, and resorts are becoming increasingly popular, and provide an enjoyable vacation as well as a chance to learn more about programming and computers. The prices vary greatly, depending on which you choose, as do the facilities and what they offer. Here's a brief sample of some notable computer-vacation activities I'm aware of, but there are many others, I'm sure.

You might find out more about other computer vacations by checking the leisure and education sections of your local Sunday newspaper. It's also a good idea to call these sources directly or have your travel agent check on what's offered and which computers are available for use. Additionally, many local day camps, YMCA/YWCA's, and Scout troops also offer computer-oriented activities during the summer, so you may want to check with them as well.

Sesame Place is sure to be a big hit with the younger computer users. This summer computer day camp offers youngsters the opportunity to learn about computing amidst the theme of the popular Sesame Street characters. And, for mom and dad, adult courses are also available. For more information, contact: Sesame Place, 100 Sesame Road, Box 579, Langhorne, PA 19047, (215) 752-4900.

The S.S. Independence is literally a computer dreamboat. It features Commodore 64's on its week-long computer cruises, and it weighs anchor at Waikiki Beach for floating seminars around the Hawaiian Islands. For more information, contact: The Travel Shoppe, 2311 Santa Clara Avenue, Alameda, CA 94501, (415) 865-5542/(415) 521-8231.

Club Med offers computer vacations at various locations. More information can be obtained from: Club Med, 3 East 54th Street, New York, NY 10022, 1-800-528-3100.

The Smuggler's Notch Foundation for Computer Use sponsors computer vacations for families in scenic Vermont. More information can be obtained from: The Village at Smuggler's Notch, Smuggler's Notch, VT 05464, (802) 644-8851.

The beautiful Catskill Mountains in upstate New York are the location of two resorts offering computer-oriented vacation agendas. Find out more about what's being offered by contacting Grossinger's at 1-800-431-6300 outside of New York state, or 1-800-874-7480 in New York state. I'm told that the Fallsview Hotel is also of interest, and can be contacted at (212) 947-4428 for more information.

Additionally, it's also a good idea to check out your local high schools and colleges to see what they have to offer in the way of summer computing curriculums. You could also try inquiries to user groups in the area of your vacation destination. Computer bulletin boards are yet another way of making that "computer vacation connection."

Wherever you spend your vacation—at home or trotting the globe—I hope you have a great time. As for myself, I'm off to Haiti and possibly Hawaii to research some articles. My faithful SX-64 is definitely coming along with me—I don't leave home without it. **C**

Chord Power

Chord Power for Guitar is music software for the Commodore 64 that features quick access to over 8,000 guitar chords. Enter the chord desired and it will be displayed and played. Chords are displayed on a 12-fret color graphic fretboard with the option of displaying chords with position dots or with the actual note letters, including sharps and flats. If the chord displays beyond the twelfth fret, then the display changes to show frets seven through 18. You may also select in which form the chord will be displayed. The program from NewArts (16783 Beach Boulevard, Huntington Beach, CA 92647) features on-line documentation and a tutorial that provides supportive information on chord-naming and structure. It retails for \$39.95.

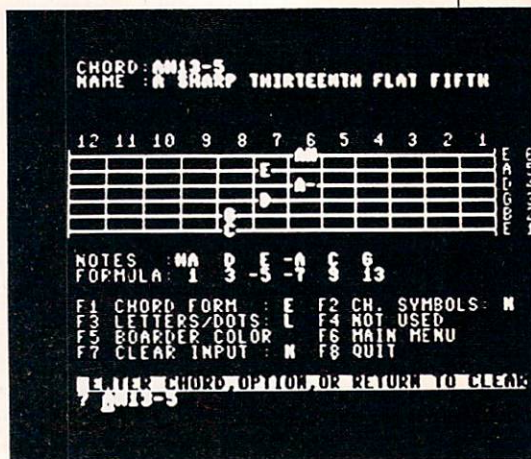

Access over 8,000 guitar chords.

Financial Planning Simulation

Squire, published by Blue Chip Software (6740 Eton Avenue, Canoga Park, CA 91303), is a simulation for the Commodore 64 that lets you experiment with actual income and expenses to arrive at a personal financial plan that will help you retire as a millionaire within 20 years.

The simulation emphasizes the time value of money, particularly inflation and interest-bearing investments, with added emphasis on tax-advantage strategies. Beginning with a capital base of \$30,000, you advance through a series of progressively complicated levels of achievement from novice to investor, speculator to broker—until you've reached your goal of becoming a squire—and a millionaire.

you could be the one to WIN \$5000 by playing the exciting game of MAD SCIENTIST 64

MAD SCIENTIST 64 is a disk based educational game for the Commodore 64tm. Actually a game within a game-You advance by solving "game clues". Along the way, you receive "solution clues" based on U.S. history & current events. Very interactive like the Adventure & Infocom games.

To promote this game, we are offering five cash prizes to the best registered game players: a Grand Prize of \$5000 and four separate second place prizes of \$2500 each. Entrants will be divided into 5 equal groups by postal zip. The Grand Prize will go to the best overall score. The highest score in the other 4 groups receive the second place prizes.

All prizes will be awarded. You must return an answer sheet. Provisions for breaking ties. Extensive protection against cheating. 15 day money back guarantee.

Game shipments begin Jun 15, 1985. Answer sheets must be received by us no later than Nov 15, 1985. Winners will be announced on Dec 20, 1985.

Only U.S. entrants are eligible for the cash prizes, & in the U.S., the cash prize is void where prohibited by law.

To receive your **MAD SCIENTIST 64** game disk, manual, blank scoresheet, and registration send \$24.95 plus \$2.00 shipping & handling to:

MADA ENTERPRISES, INC.

**P.O. BOX 1382
BELLEVUE, NE. 68005**

For more information write or circle reader service number.
Commodore 64 is a trademark of Commodore Electronics, Ltd.

TESTING

...JUST GOT EASIER!

TESTMASTER-ONLY \$35.00

- ★ END TEST RE-TYPING FOREVER!
- ★ EFFORTLESSLY PRODUCE MULTIPLE CHOICE, TRUE-FALSE, SHORT ANSWER, COMPLETION TESTS
- ★ BUILD A BANK OF TEST ITEMS TO USE FROM YEAR TO YEAR
- ★ UPPER / LOWER CASE AND COMPLETE EDITING FACILITIES
- ★ PRODUCE TESTS FROM 1 TO 999 ITEMS
- ★ PRODUCE ALTERNATE FORMS OF THE SAME TEST
- ★ PRINTS ANSWER KEY AND MATCHING STUDENT RESPONSE SHEET FOR EACH FORM PRINTED

FOR COMMODORE 64, 32K PET, APPLE II FAMILY
- DISKS ONLY -

FREE TRIAL IN YOUR SCHOOL FOR 30 DAYS

Please Add \$2.00 Per Order For Postage and Handling
SEND FOR OUR FLYER OF OTHER USEFUL SOFTWARE
WRITTEN BY TEACHERS FOR TEACHERS



MIDWEST SOFTWARE

Box 214 Farmington, MI 48024
Phone (313) 477-0897

VISA / MASTERCARD

INDUSTRY NEWS

Invisible Modem for the Commodore 64

Trans Com (703-13 Annoreno Drive, Addison, IL 60101) has introduced the TCM-1 Modem and terminal software for the Commodore 64. The TCM-1 mounts inside the computer, leaving the user port free for peripherals. Features include auto-answer/auto-dial, computer-powered (no need for external power supply), modular phone jack, visual "carrier-detect" LED, and a terminal software program to introduce telecommunications. (New users please take note that opening your Commodore 64 to install such a device—or for any reason—will void your warranty.)

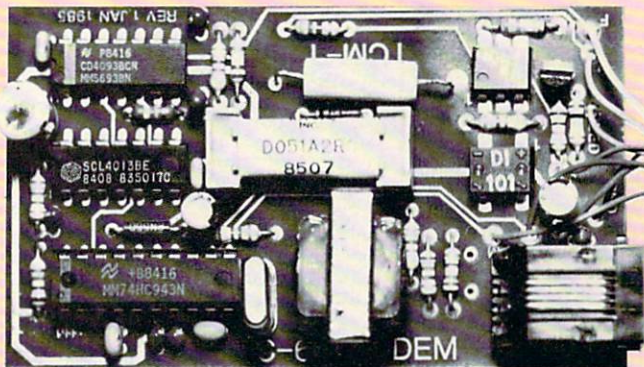

The TCM-1 Modem mounts inside your computer.

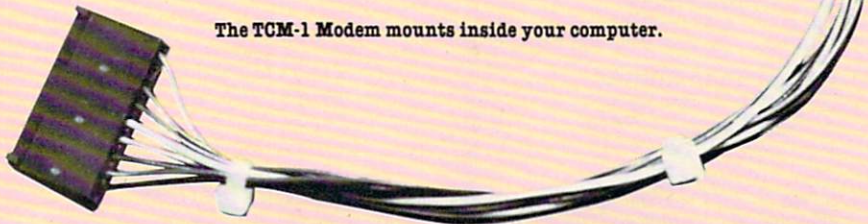

Help for Marketing your Software

The Software Authors Bureau offers program writers and publishers information on demonstrating and marketing their software.

For a one-time fee of \$100, a software author or publisher can learn how to prepare demo disks containing individual screens which clearly illustrate the benefits and advantages of their programs. Examples are provided of effective screen designs as used in actual on-line interactive demonstrations.

Contact the Bureau at Software Information Systems, Fairfield Business Campus, 376 Hollywood Avenue, Fairfield, NJ 07006.

Telecommunications Guide

Chilton Book Company (Radnor, PA 19089) has released a guide to the world of electronic communications entitled **Plugging In: the Microcomputerist's Guide to Telecommunications**.

Plugging In helps users get the most out of their personal computers by showing how to make wise buying decisions, determining in advance the particular applications needed. It details what is available where, and teaches how to use the selected resources efficiently and economically. To further assist with comparison shopping, a hardware and software checklist evaluates compatibilities and capabilities.

The author evaluates and provides on-line samples of many private and public services, including CompuServe, The Source, and Dialog's Knowledge Index. Explore the commercial realm of time-sharing services, electronic data bases, consumer and specialized on-line services, and information utilities, as well as the free services available on hundreds of community bulletin boards across the country.

Plugging In also discusses key self-help techniques for using an acquired service to the best advantage, and designing a good database search strategy. The user will learn how to avoid the cost of a specialized search by becoming a personal information broker, how to start one's own bulletin board, and how to transform the terminal into a portable encyclopedia.

The book is available for \$11.95.

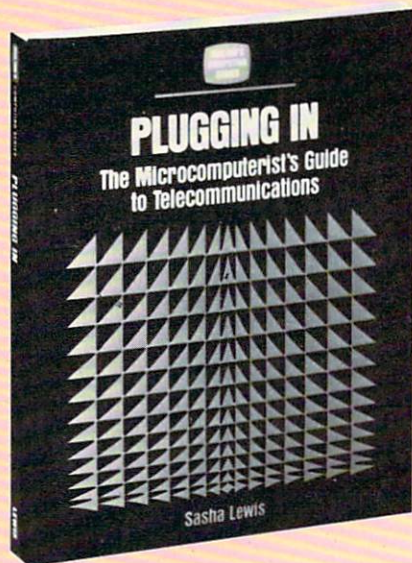

Access a wide variety of information.

**ATTENTION COMMODORE
64 USERS!**

Investment Software

STOCK SELECTOR

Easily files *stock data* such as P/E or stock prices and makes ranks. Shows you which stocks to buy and sell. \$59.95

MARKET TIMER

Stores *stock indexes* such as DJIA and yields market signals or risks. Determines when you should buy and sell stocks. \$59.95

Educational Software

BASIC TYPE

Improve your typing skills and speed as you do exercises on the keyboard and words & sentences. Over 330 lessons. \$25.95

ANTONYMS & SYNONYMS

Prepares you for school work and standardized tests. Countless number of questions. \$27.95

WORD QUEST

Three new fun-filled word games. 2400 well-chosen words. \$23.95

CompuTech Software, Inc.

57 S. Spruce St.
Ramsey, NJ 07446
(201) 825-4844

C.O.D., MONEY ORDER, or check. NJ res. add 6% tax. Canada & Foreign: add \$5 per order with MONEY ORDER (US dollars only).

Commodore 64 is a trademark of Commodore Business Machines, Inc.

Circle Reader Service No. 6

Advertiser Index

	Reader Service No.	Page No.
Academy Software	1	93
Apropos Technology	2	CIV
Batteries Included	*	17
Cardco	3	CIII
Cheatsheet Products	4	97
C.M.S. Software	5	2
Commodore Software	*	19, 29, 65
Commodore Corporate	*	CII/1, 5, 14/15, 80/81
Computech Software	6	128
Computel	29	52
Computer Novelty	7	6
Digital Vision	8	35
Fiscal Information Services	9	9
Howard W. Sams & Co., Inc.	10	25
Inexsoft	21	6
Integrated Software Systems	11	89
Intelligent Software	*	93
Loadstar	12	91
Megasoft Ltd.	13	38/39
Microtechnic Solutions	14	43
Midwest Software	15	126
Mimic Systems	16	7
Muse Software	17	31
P.D.S. Sports	18	33
Phonemark	30	103
Protecto Enterprizes	20	56-61
Smada Enterprizes	22, 23	35, 126
Star Micronics	24	37
SubLogic Corporation	25, 26	21, 23
Superior Micro Systems	27	128
Systems Management Associates	28	48, 49
Tenex	31	92

*No Reader Service No. Given

Circle Reader Service No. 27

Introducing **LOTTERY 64®**



LOTTERY 64® has been designed to use the computing power of the Commodore-64™ to help you play the various lottery games; PICK 3, PICK 4, LOTTO, SUPER LOTTO, 6/49, LUCKY LOTTERY, etc. It can be used with any lottery game in which you pick the numbers.

We have already won thousands of dollars with it. It can work for you too!

AVAILABLE ON DISKETTE ONLY.

To order, send \$24.95 for each plus \$3.00 postage and handling per order to:

MS Superior Micro Systems, Inc.
P.O. Box 713 • Wheeling, IL 60090
Dealer inquiries welcome!

Commodore 64™ is a registered trademark of Commodore Electronics, Ltd.

CARDCO's new DIGI-CAM™ is a video digitizer that lets you transform just about anything you can shoot with a video camera into a black-and-white digital image. And, with your Commodore 64[®], you can make pictures of that image.

DIGI-CAM™ comes complete with a black-and-white video camera, a digitizer, and software. It's the most comprehensive package at the most competitive price around. And it's a CARDCO quality product.

FOCUS...SHOOT...STORE... AND PRINT!

DIGI-CAM™ is incredibly easy to use. Simply focus the video camera on your subject, view the shot on your Commodore 64[®] monitor, store the shot on CARDCO's DIGI-CAM™ software ... and print out. You can enhance or change the on-screen



image — or combine it with text — because a version of CARDCO's Paint Now/Graph Now software is built in ... at no extra cost!

Make T-shirts for your friends**, Christmas cards and birth announcements ... maps, graphs, photos, security i.d.'s ... use it for business or pure pleasure. Plus, you can transfer still images via modem to other Commodore[®] computers ... and share your shots! (Soon to



be compatible with Apple and IBM.)

**CAMERA, DIGITIZER,
SOFTWARE... THE
WHOLE PICTURE
FOR \$250***

DIGI-CAM™ from
CARDCO. For just \$250



... shouldn't you be in pictures?

CARDCO's DIGI-CAM™ is available at fine computer stores everywhere. For more information contact your local CARDCO dealer.



cardco, inc.

"The world's largest manufacturer of Commodore[®] accessories."
300 S. Topeka, Wichita, Kansas 67202

* Suggested retail — prices may vary.
** Special heat-transfer ribbon required.

FOR \$250*.. YOU OUGHTA BE IN PICTURES!



AMAZING DAISY

NOW! FULL SIZE, FULL FEATURE, LETTER QUALITY AT ONLY \$353

If you have been searching for a letter quality printer you probably found that the flood of claims and counterclaims were a real roadblock in your search. Not long ago we were in the same position. We tried to determine which daisy wheel printer had all the features anyone could want, but would also appeal to the cost conscious buyer. Recently several manufacturers introduced printers that had features we were seeking. After a thorough assessment we eliminated all but one which precisely met our qualifications.

THE RESULTS ARE IN

We found the printer which has all the features anyone could want. We've named it the Aproték Daisy 1120, a real heavy-duty workhorse printing at 20 characters per second. The manufacturer is Olympic Co. Ltd., a highly respected Japanese firm.

FEATURES GALORE

This printer has it all. To start with, it has a front control panel with indicators for Pitch Selection which allows for 10, 12, or 15 characters per inch (CPI) or Proportional Spacing. There is a Select (Online) button (with indicator) and a Line Feed button. You can also set Top-of-Form or Form Feed with the touch of the TOF button. Other front panel indicators include Power and Alarm.

To load a sheet of paper, simply place it in the feed slot and pull the paper bail lever. The paper feeds automatically to a 1 inch top margin and the carriage aligns to the selected left margin. In this manner, each page can have identical margins.

You can continue to use your Commodore while the Daisy 1120 is printing.

The built in 2K buffer allows a page or two of concurrent printing and use of your computer for the next job. To really take advantage of your printer's optional features, the automatic Cut Sheet Feeder eliminates tiresome paper handling. Also available is the adjustable Tractor Feed option. *Compare our option prices!*

Best of all the Daisy 1120 is quiet: only 57 dB-A (compare with an average of 62-65 dB-A for others).

COMPLETE COMPATIBILITY

The Daisy 1120 uses industry standard Diablo® compatible printwheels. Scores of typeface styles are available at most computer or stationary stores. You can pop in a 10, 12, 15 pitch or proportional printwheel and use paper as wide as 14". At 15 CPI you can print 165 columns—a must for spreadsheet programs.

The Daisy 1120 uses the Diablo Hytype II® standard ribbon cartridges. Again universally available.

Not only is the hardware completely compatible, the control codes recognized by the Daisy 1120 are Diablo 630® compatible (industry standard). You can take advantage of all the great features of word processing packages and automatically use superscripts, subscripts, automatic underlining, bold-face (shadow printing) and doublestrike.

The printer has a set of rear switches which allow the use of standard ASCII as well as foreign character printwheels. Page length can be set to 8, 11, 12, or 15". The Daisy 1120 can also be switched to add automatic line feed if required.

THE BEST PART

When pricing a daisy wheel printer with all these features (if you could find one), you would expect to pay \$600 or \$700 dollars. The options would add much more, but our exhaustive research has paid off for you the Commodore user. We can now offer this printer for only \$353. Order yours today!

NO RISK OFFER

Try the Daisy 1120 for 2 weeks. If you are not satisfied for ANY reason we will refund the full price—promptly. A full 1-year parts and labor warranty is included. Another indication of quality and reliability.

THE BOTTOM LINE

Aproték Daisy 1120 (Order#1120) \$353 w/standard Centronics parallel interface and 2K buffer.

Options

Auto Cut Sheet Feeder (#1110) \$188

Tractor Feed (#1112) \$77

Interface with cable for all Commodore (except PET) (#1105) \$44

Ask about cables and interfaces for other computers.

Shipping is \$11—UPS continental USA. If you are in a hurry, UPS Blue or Air Parcel Post (second day air) is \$25. Canada, Alaska, Mexico and Hawaii are \$30 (air). Other foreign is \$60 (air). California residents add 6% tax. Prices are cash prices—VISA and M/C add 3% to total. We ship promptly on money orders, cashier's checks, and charge cards. Allow 14-day clearing for checks. No C.O.D.'s. Payment in US dollars only.

TO ORDER ONLY CALL TOLL FREE

(800) 962-5800 USA (8-8 PST)
(800) 962-3800 CALIF.

Or send payment to address below:

Be sure to include order numbers with all items.

Technical Information & Customer Service: (805) 987-2454 (8-5 PST)

Dealer Inquiries Invited

©1985 APROTEK. All rights reserved.
Trademarks: Diablo, Hytype II,
630-Xerox Corp; PET, CBM.

